

# 2012 Wastewater Collection and Treatment Report

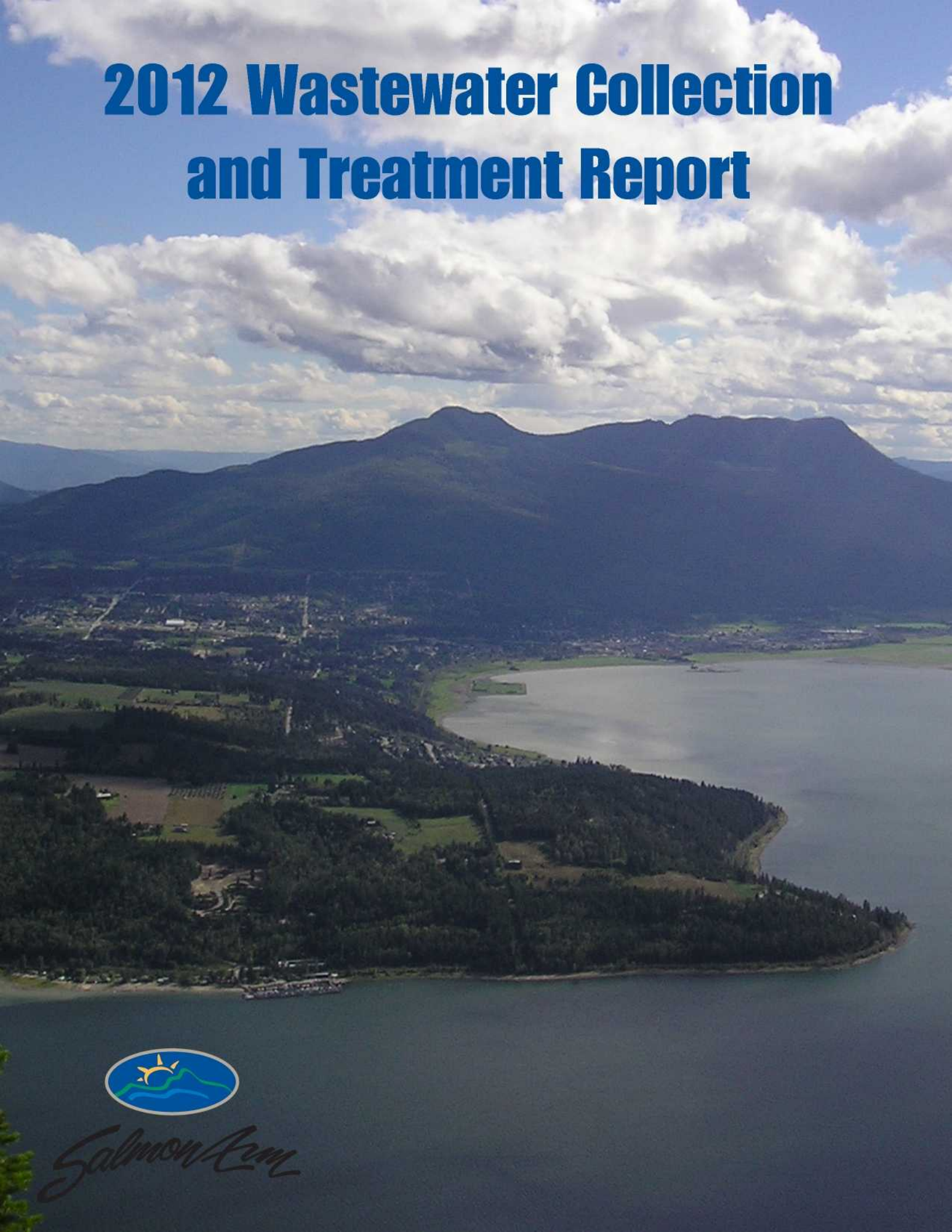

*Salmon Arm*

# TABLE OF CONTENTS

	Page #
<b>1.0 Community General</b>	2
1.1 Staffing	3
<b>2.0 Wastewater Collection System</b>	4
2.1 Wastewater Collection System History	4
2.2 Wastewater Treatment Plant History	5
<b>3.0 Wastewater Treatment and Collection System</b>	7
3.1 Overview of Collection System	7
3.2 Collection System	7
3.3 Lift Stations	7
3.4 Wharf Street Pump Station	8
3.5 Lift Station Repairs and Modifications	8
3.6 Sanitary Flushing	8
3.7 Main and Service Interruptions	8
3.8 Inflow and Infiltration Monitoring	8
3.9 Wastewater Collection Capital Projects	9
<b>4.0 Water Pollution Control Centre (WPCC)</b>	10
4.1 Process Overview	10
4.2 Flows	13
4.3 Nutrient Removal	14
4.4 Fecal Coliform	16
4.5 Toxicity	16
4.6 Biosolids	16
4.7 Operating Certificate	17
4.8 Liquid Waste Management Plan	17
4.9 WPCC Capital Projects	17

**APPENDIX A** Map 3.2 District of Salmon Arm Wastewater Collection System  
Dayton & Knight (figure 4.1)

**APPENDIX B** Operational Certificate

## 1.0 Community General

The City of Salmon Arm is located in the southern interior of British Columbia on the southwest shoreline of the extensive Shuswap Lake system. With over 17,000 residents, Salmon Arm is the largest urban centre in the Columbia Shuswap Regional District. It serves as the commercial, cultural and administrative hub for an additional 35,000 residents of the Shuswap Lake region. Located at the junction of the Trans Canada Highway (TCH) and Highway 97B, Salmon Arm is a one-half day drive to Vancouver or Calgary and a 70 minute drive to Kelowna or Kamloops.

With a land base of 175 km<sup>2</sup>, Salmon Arm is a relatively large municipality by area with most of the population concentrated within a few kilometers of the Trans Canada Highway and the downtown core. The surrounding terrain varies from the low lying marsh flats of Salmon Arm Bay to the extinct volcanic peak of Mt. Ida and the ridge lines of Fly Hills to the west and Larch Hills to the east. These highlands form the Canoe Creek and Salmon River watersheds which empty into Shuswap Lake. Sustainable land use planning over the years has resulted in the formation of an attractive, bustling, compact community surrounded by thousands of hectares of arable farmland, green space and natural shorelines.



Salmon Arm's commercial and industrial base is continuing to diversify. The housing market continues to remain tight. Retail, construction, professional services and healthcare, along with a wide array of entrepreneurial activities, are major sources of employment. Small businesses



flourish in Salmon Arm's business friendly environment. Key economic drivers are value-added wood processing, high tech and traditional manufacturing, tourism and agri-business. The continuing surge in construction activity points to a healthy market demand for new housing and floor space for commercial, industrial and institutional uses. The 2011 Census indicates a percentage growth in population of 9.1% from the previous 2006 Census. This compares to the national average growth of 5.9%.

## 1.1 Staffing

The City of Salmon Arm Engineering and Public Works Department is responsible for this municipal function. The Utilities Division is responsible for the operation and maintenance of the sanitary collection system and the Water Pollution Control Centre (WPCC) staff is responsible for the operation and maintenance of the Wastewater Treatment facility and the main lift Station located at Wharf Street. The WPCC is manned seven days of the week with 24-hour standby provisions for after hour alarm response.

**Table 1 - Staff Overview**

Engineering and Public Works	
<b>Robert Niewenhuizen</b> , A.Sc.T., Director of Engineering and Public Works	
<b>Jenn Walters</b> , P.Eng., LEED® AP, City Engineer	
Utilities Division	
<b>Gerry Rasmuson</b> , B.Sc. <i>Utilities Manager</i> <ul style="list-style-type: none"> <li>◆ Level IV - Water Distribution</li> <li>◆ Level IV - Wastewater Treatment</li> <li>◆ Level I - Wastewater Collection</li> </ul>	<b>Larry Kipp</b> <i>Utilities Supervisor</i> <ul style="list-style-type: none"> <li>◆ Level I - Wastewater Collection</li> </ul>
<b>Mervin Arvay</b> <ul style="list-style-type: none"> <li>◆ Level I - Wastewater Collection</li> </ul>	<b>Devon Tulak</b> <ul style="list-style-type: none"> <li>◆ Level I - Wastewater Collection</li> </ul>
<b>Ray Muller</b> <ul style="list-style-type: none"> <li>◆ Level I - Wastewater Collection</li> </ul>	<b>Tyler Stevenson</b> <ul style="list-style-type: none"> <li>◆ Level I - Wastewater Collection</li> </ul>
Water Pollution Control Centre	
<b>Hart Frese</b> , WPCC Manager <i>Chief Operator</i> <ul style="list-style-type: none"> <li>◆ Level IV - Wastewater Treatment</li> </ul>	<b>Doug Stalker</b> , Dip. Water Quality <i>Operator III</i> <ul style="list-style-type: none"> <li>◆ Level IV - Wastewater Treatment</li> <li>◆ Level I - Wastewater Collection</li> </ul>
<b>Conor O'Neill</b> , Dip. Water Quality <i>Operator III</i> <ul style="list-style-type: none"> <li>◆ Level IV - Wastewater Treatment</li> </ul>	<b>David Knowles</b> <i>Operator I</i> <ul style="list-style-type: none"> <li>◆ Level I – Wastewater Treatment</li> </ul>

## 2.0 Wastewater Treatment & Collection System History

### 2.1 Wastewater Collection System - History

The District of Salmon Arm and the Village of Salmon Arm amalgamated in 1971 to form the District Municipality of Salmon Arm on January 1, 1971, and then became the City of Salmon Arm in 2005. The Village was the original urban core area and sewer lines were installed during the 1930's to collect septic tank effluent and some crude wastes which were then discharged into an open ditch leading into Shuswap Lake. The surrounding District Municipality relied on septic systems as sewer collection was not an issue until the urban development of the Village overflowed into the surrounding Municipality. By 1964, the Village had initiated plans for sewage treatment which included the construction of a lagoon along the waterfront for treatment. The lagoons would also service the Adams lake Indian Band lands. Concerned about the level of treatment that a lagoon offered, the Village decided to review their plans and objectives. By 1966, the review board recommended that the Village and District combine in their efforts to collect and treat wastewater. However, unable to agree upon implementation of various plans the Village applied to the Pollution Control Board for a permit to discharge highly treated effluent into Shuswap Lake. By the



time this permit was granted in 1972, the Village and District had amalgamated. Ultimately the Engineering firm of Dayton and Knight Ltd were hired to undertake a Wastewater survey in 1972 to study various different treatment and effluent disposal methods. The Survey resulted in the construction and official opening of the existing Water Pollution Control Centre on May 14, 1977. Furthermore, the survey identified collection system priorities and set in motion the construction of the infrastructure that currently exists. The City's sewage collection and treatment systems have evolved into a well maintained collection system and a state of the art Wastewater Treatment Centre.

Ultimately the Engineering firm of Dayton and Knight Ltd were hired to undertake a Wastewater survey in 1972 to study various different treatment and effluent disposal methods. The Survey resulted in the construction and official opening of the existing Water Pollution Control Centre on May 14, 1977. Furthermore, the survey identified collection system priorities and set in motion the construction of the infrastructure that currently exists. The City's sewage collection and treatment systems have evolved into a well maintained collection system and a state of the art Wastewater Treatment Centre.

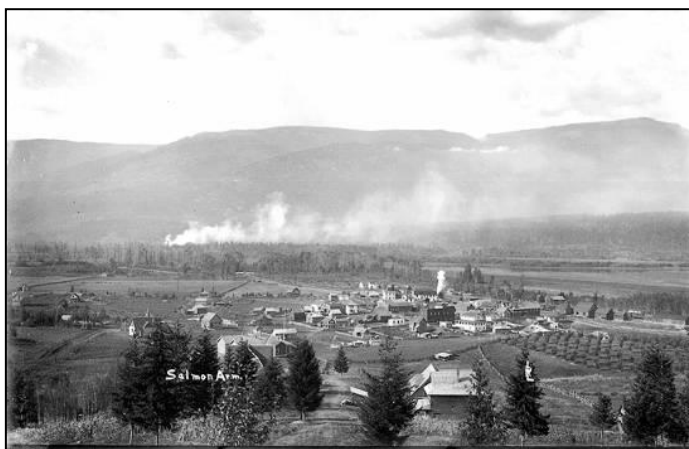

## 2.2 Wastewater Treatment Plant History

The original plant was constructed on the current site, 121 Narcisse Street NW, in 1977 after the proposed site at Minion Field, 2191 30<sup>th</sup> Street SW was rejected by the B.C. Agricultural Land Commission and Provincial Pollution Control Board. It was constructed at a cost of \$0.9 M and consisted of primary sedimentation, activated sludge, secondary clarification with chlorine disinfection. Solids were aerobically digested and stored in two 1 acre lagoons. Capacity of the plant was 3,000 m<sup>3</sup> per day for a design service population of 6,250.

In 1982, phosphorus removal was added at a cost of \$0.1 M and consisted of precipitating phosphorus out of the effluent by the addition of ferrous chloride. Phosphorus was determined to be the limiting nutrient which contributes to the eutrophication and degradation of water quality in Shuswap Lake, particularly, Salmon Arm Bay. Currently the Salmon Arm WPCC contributes less than 4% of the phosphorus loading in the bay.



Aerial Photo Stage IIIB prior to Landscaping

In 1986 the \$1.8 M Stage II Upgrade was the first major upgrade to the facility. The liquid process was altered from a common activated sludge process to an experimental trickling filter biological nutrient removal (BNR) system (Fixed Growth Reactor – Suspended Growth Reaction or FGR-SGR). As well, the aerobic digester was upgraded to an Autothermal Thermophilic Aerobic Digester (ATAD). Plant Capacity was increased to 3,500 m<sup>3</sup> per day for a design service population of 8,750.

Improvements were made in 1991 to the solids process at a cost of \$0.5 M. The improvements consisted of changing aeration and solids pumping equipment. Rebuilding the ATAD tanks and added waste biological sludge thickening.

The Stage III Upgrade was split into two upgrades with the first part, Stage IIIA completed in 1998 at a cost of \$5.2 M. It consisted of improvements to the FGR- SGR process, new secondary clarifier, Supervisory Control and Data Acquisition system, increased ATAD capacity and biosolids dewatering. These improvements led to better control and monitoring, the ability to beneficially recycle biosolids and the decommissioning of the solids storage lagoons. Capacity was increased to 5,000 m<sup>3</sup> per day for a design service population of 12,900.

Stage IIIB was completed in 2005 without the Laboratory/Administration expansion. Of the \$7.4 M upgrade, \$2.3 M was funded by the Federal and Provincial Governments.

The upgrade consisted of a complete rebuild of the main lift station at Marine Drive with odour control, added redundancy to critical equipment, stand-by power, effluent filtration, replacement of the chlorination/de-chlorination system with Ultra Violet disinfection, an elaborate odour control system and architectural improvements to the original exterior of the original building.

## 2.2 Wastewater Treatment Plant History (Cont'd)

Capacity was increased to 6,700 m<sup>3</sup> per day average flow for a design service population of 15,000. Stage IIIB was completed in 2008 with the \$0.4 M expansion of the Laboratory/Administration area. The Water Reclamation project was completed in 2010. This project utilizes the highly treated effluent for process water at the facility resulting in a 110 ML annual reduction in potable water use. In 2011, the Trickling Filter Media Upgrade was completed.



The total cost of the project was \$0.55 M and entailed removing approximately 1,560 m<sup>3</sup> of crossflow media and replacing with vertical flow media. This project was the result of the September 2007 pilot study (Dayton & Knight Ltd.) designed to reduce the impact of sloughing conditions currently problematic at the facility.

**Table 2 - Cost Summary Table**

Project	Cost	Year
Stage I - 6,250 connected population	\$0.9 M	1977
Chemical Phosphorus Removal	\$0.1 M	1982
Stage II - 8,250 connected population	\$1.8 M	1986
Solids Improvements	\$0.5 M	1991
Stage IIIA - 12,500 connected population	\$5.3 M	1998
Stage IIIB – 15,000 connected population	\$7.4 M	2004
Laboratory/Administration Expansion	\$0.4 M	2008
Reclaimed Water	\$0.1 M	2009
Trickling Filter Media Upgrade	\$0.55 M	2011
<b>Total</b>	<b>\$17.05 M</b>	
Estimated Insurable/Replacement Value (2005)	\$35.0 M	

### 3.0 Wastewater Collection System

#### 3.1 Overview of Collection System

The Utilities Division, through a schedule of systematic new improvements, upgrades and replacements strives to maintain and improve the sanitary sewer collection system. This Division plays an integral role in maintaining the health, safety and well being of the community. The sewer utility is a self-liquidating funded system which must provide for their own revenues through fees, taxes and other charges to support the expenditures required to operate and maintain infrastructure on a daily basis and long into the future.

#### 3.2 Collection System

The City of Salmon Arm’s sanitary sewer collection system consists of 14 sewerage sub areas and 128 km of gravity and force main sanitary sewer pipes covering approximately 1800 hectares. There are approximately 5,962 residential, commercial, industrial and institutional lots fronting onto the sanitary sewer system (2012 Sewer Frontage Tax Assessment Roll). There are eight (8) sewer lift stations that collect and pump sewerage to the Lakeshore Sewer Interceptor located on the foreshore where the main lift station, Wharf Street Pump Station, pumps the sewerage directly to the WPCC (see Map 3.2). The Interceptor provides storage and flow equalization capabilities.

#### 3.3 Lift Stations

All eight of the tributary Lift stations are inspected once a week by the City of Salmon Arm’s Utilities Division. All lift stations are thoroughly inspected and cleaned on a monthly basis. The stations are monitored using the City’s SCADA system which enables staff to troubleshoot and trend data on the Cities SCADA system.

**Table 3 - Wastewater Facilities**

No.	Wastewater Lift Stations & Facilities	Address
1	Water Pollution Control Centre	121 Narcisse Street NW
2	Mosquito Park Lift Station	4290 Canoe Beach Drive NE
3	Clare's Cove Lift Station	5391-75 Avenue NE
4	Tippy Canoe Lift Station	Pump in MH under road at 50 <sup>th</sup> Street & 75 <sup>th</sup> Avenue NE intersection
5	Captain’s Cove Lift Station	2251-73 Avenue NE
6	Canoe Beach Lift Station	7720-36 Street NE
7	Wharf Street Pump Station	1000 Marine Park Drive NE
8	Rotten Row Lift Station	681-10 Avenue SW
9	10 Avenue SW Lift Station	2270-10 Avenue SW [TCH]



### **3.4 Wharf Street Lift Station**

The Wharf Street Lift station is gravity fed by the Lakeshore Interceptor. Three 30 Hp pumps with variable speed drives are used to feed the wastewater facility at rates determined by WPC operators. The station was upgraded in 2002 with each pump rated at 80 liters/sec flow. The foul air is treated by utilizing ultraviolet light which catalyses the breaking of ambient oxygen and water vapor molecules into O<sup>+</sup> and OH<sup>-</sup> ions. These free radicals oxidize the odorous contaminants in the air. This reaction results in a sequential and instantaneous gas breakdown of the contaminants with minimal by-products, such as elemental sulfur, CO<sub>2</sub>, water vapor, molecular oxygen and trace ozone. In the event of an extended power outage, there is the capability to connect the City's portable generator to the station to run the pumps. A second portable generator was purchased in 2011 primarily to service this critical lift station. This generator was utilized in July of 2012 when a primary Hydro feed to the electrical sub station failed resulting in a localized 33 hour power outage.



### **3.5 Lift Station Repairs and Modifications**

In 2012, the City raised the sanitary lift station at the Canoe Public Beach above the 200 year flood level elevation. Another new pump was purchased for 10<sup>th</sup> Ave SE lift station and pumps at both Mosquito Park and Claires Cove lift stations had repair kits installed. A fence was also installed around Claires Cove lift station to secure the site.

### **3.6 Sanitary Flushing**

Approximately 24km of sanitary mains were flushed in 2012 as part of the maintenance program. Certain areas and services of concern as well as historically troublesome areas are flushed annually. In 2012, the Utilities Division completed flushing of the numerous sanitary mains in Right of Ways within the collection system that are difficult to access.

### **3.7 Main and Service Interruptions**

There were not any mainline blockages within the sanitary collection system in 2012 and only a handful of service interruptions typically attributed to grease build up within the service pipe from homeowners or roots from nearby trees and shrubbery.

### **3.8 Inflow and Infiltration Monitoring Program**

The program identifies locations where storm water or ground water enters the sanitary system. We continue to provide system improvements in an effort to reduce the amount of rainwater and groundwater entering the sanitary sewer system when it is cost-effective to do so. Reduction of Inflow & Infiltration (I&I) in the system lowers the risk of sanitary sewer overflows and can decrease the costs of conveying and treating wastewater.

### 3.9 Wastewater Collection Capital Projects

**Table 4 - Capital Project Information**

Capital projects completed in 2012
◆ Pump #3 rebuilt at Wharf St. Lift Station
◆ Raised Canoe Beach lift station.
◆ Upgrade sanitary main crossing the CPR ROW at 20 Avenue and Lakeshore Road NE.
◆ Construct sanitary main crossing of CPR ROW in the 4500 Block along Canoe Beach Drive NE
◆ Purchased new sanitary main crawler
◆ Ongoing SCADA and GIS development
Capital Projects scheduled for 2013
◆ Ongoing SCADA and GIS development.
◆ Sanitary Foreshore replacement predesign
◆ Renew the sanitary main between 51 <sup>st</sup> and 52 <sup>nd</sup> St NE
◆ Update Sanitary Sewer Master Plan

#### 4.0 Wastewater Treatment - Water Pollution Control Centre (WPCC)

The City of Salmon Arm WPCC is located at 121 Narcisse Street N.W. which is located west of the City’s Town Centre adjacent to the Shuswap Lake. This section of the report will detail the performance and operational strategies of the plant during the past year.



WPCC – After renovations



Wharf Street Lift Station

#### 4.1 Process Overview

The process of wastewater treatment can be separated into two flow streams – liquid and solids also referred to as the liquid train and solids train.

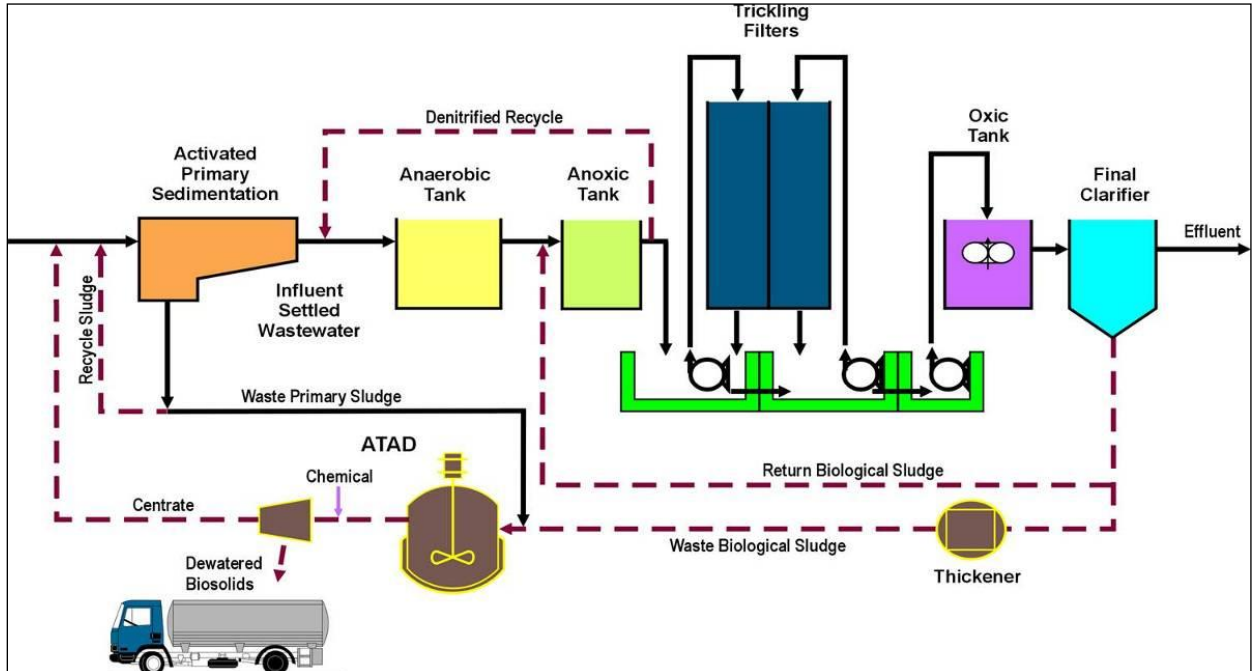

**Figure 1:** Wastewater Treatment Overview

Initially the wastewater flows into the plant from a sewage lift station located at Marine Park Drive. The influent then passes through several mechanical devices to remove large particles

City of Salmon Arm  
2012 Annual Wastewater Collection and Treatment Report

including rocks, rags, plastics and grit. This is done in the headworks of the facility and prevents damage to downstream equipment.



Headworks



Primary Sedimentation Tanks

The flow then enters the Primary Sedimentation Tanks where heavier organic and inorganic solids are settled out of the liquid stream. These particles are then pumped to the ATAD for stabilization. The liquid, on the other hand, then enters the tertiary BNR and SGR-FGR part of the facility for further treatment.



SGR's



FGR

The tertiary treatment involves the use of bacteria to convert degradable organic matter into bacterial cells. These cells are then separated from the liquid in the secondary clarifiers.

The growth portion of the bacteria is removed from the process by thickening and pumped to the ATAD while the remainder is recycled back to the incoming wastewater. This maintains a balance of food (wastewater organics) to micro organisms.

The secondary effluent then passes through the Aqua Aerobics disk filtration system which provides 10 micron filtration, the effluent is then disinfected using a Wedeco Ideal Horizons Ultra Violet Light (UV) disinfection system prior to it being discharged into the Salmon Arm Bay in the Shuswap Lake.

City of Salmon Arm  
2012 Annual Wastewater Collection and Treatment Report

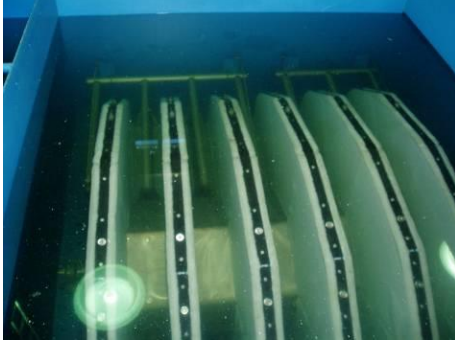

Cloth Disk Filters



Secondary Clarifiers



UV Treatment System



UV Bulbs

Solids are digested to form biosolids in the high temperature ATAD. This process uses high temperature bacteria (60 to 70 degrees Celsius) to stabilize and pasteurize the biosolids. Following processing, the biosolids are thickened with the use of high speed centrifuges and the biosolids are then incorporated with soil to produce a high quality top soil.



Centrifuge



Train B Odour Scrubber

Odour control is another major component of the plant operation. The odour control has been separated into two trains based on the concentration of odour generating compounds. One train deals with a large air volume of low odour concentration while the second train deals with a low air volume with a high concentration of odour compounds. The latter system uses a multi treatment system – biofilter, ozone contact, four (4) stage chemical scrubber and dilution while the other system uses a single stage chemical scrubber.

City of Salmon Arm  
2012 Annual Wastewater Collection and Treatment Report



Single Stage Chemical Scrubber



ATAD & Piping



Generator Set, Train B - Odour Control and Filtration Building

## 4.2 Flows

Plant flow averaged 4,382 m<sup>3</sup> per day for the year. The highest flow was recorded on June 29<sup>th</sup> when a breach in the foreshore intercept increased the 24-hour total influent flow to 9,595 m<sup>3</sup>. Overall, average flows have decreased from the peak daily average of 4,698 m<sup>3</sup> in 2009 due mainly to the City's continued efforts in addressing and rectifying areas of infiltration.



Outfall with marker buoy

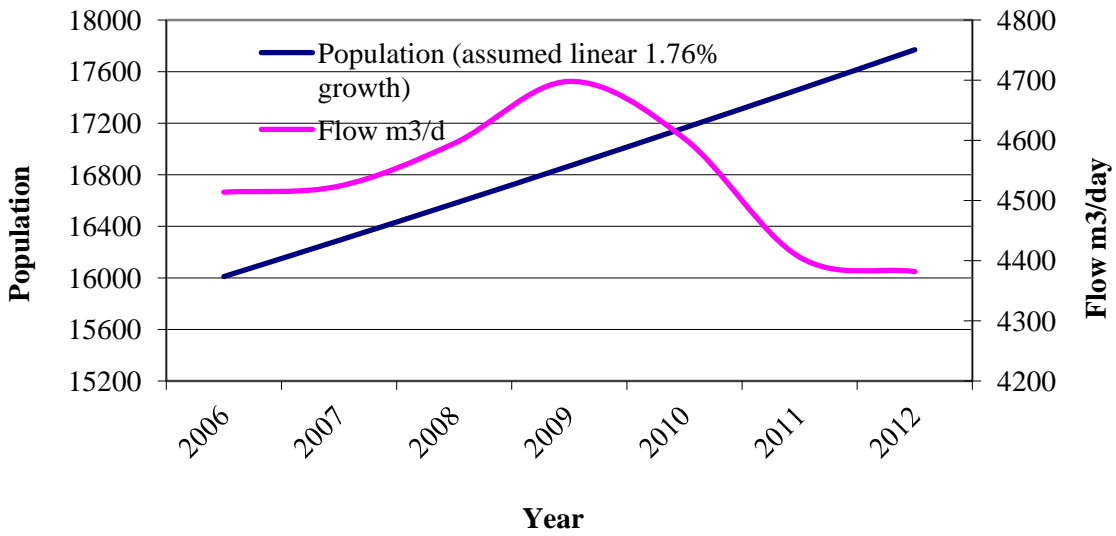

**Figure 2:** Yearly Average Daily Flow

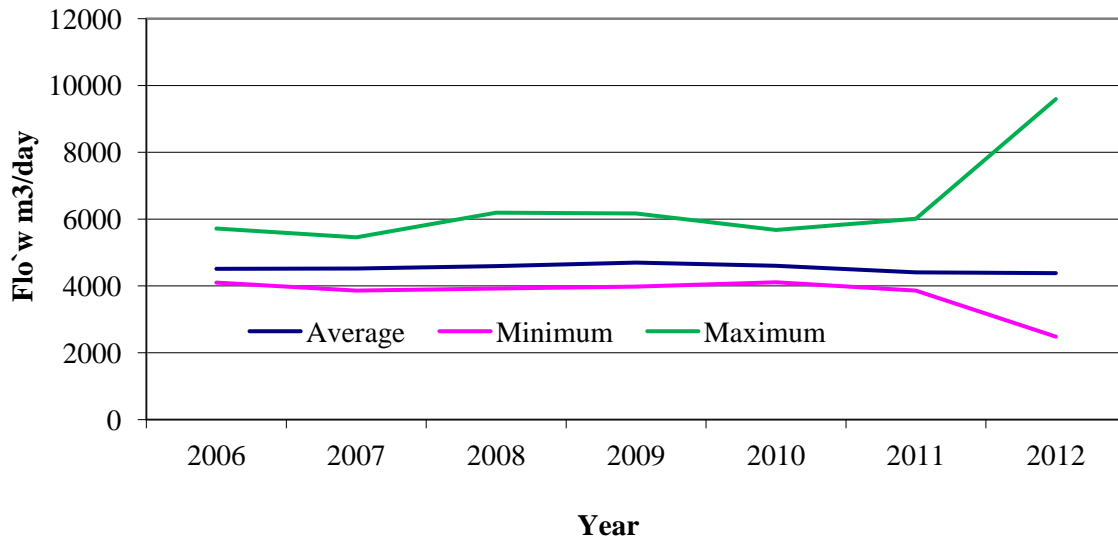

**Figure 3:** Minimum, Maximum and Average Daily Flows

### 4.3 Nutrient Removal

Phosphorus concentration is the key nutrient contributing to poor water quality in the Salmon Arm Bay as it is in most lakes in British Columbia. The WPCC contributed approximately 3% of the phosphorus loading to the Salmon Arm Bay in 2012.

City of Salmon Arm  
2012 Annual Wastewater Collection and Treatment Report

**Table 5 – Phosphorus Mass Loading to Salmon Arm Bay from Salmon River, White Creek, Tappen Creek and Salmon Arm WPCC at 2012 Concentration and Flow – Daily Annual Averages**

Total Mass Load (kg/d)	Salmon River* 1985 - 1999		White Creek* 1987 - 1990		Tappen Creek* 1988 - 1990		WPCC Year 2012	
	(kg/d)	% of Total	(kg/d)	% of Total	(kg/d)	% of Total	(kg/d)	% of Total
75.0	65.7	86%	6.9	9%	0.9	1%	2.55	3%

• \*Data supplied from WPCC Outfall Impact Study, August 2002 (Dayton & Knight Ltd.)

**Table 6 - Effluent Quality Summary - Yearly**

Parameter (mg/l)	2006	2007	2008	2009	2010	2011	2012	Permit
Flow (m <sup>3</sup> )	4514	4524	4595	4698	4603	4406	4382	8200
Total Phosphorus (mg/l)	0.38	0.45	0.64	0.66	0.49	0.35	0.58	1.0
Kg P per Day	1.72	2.04	2.94	3.07	2.26	1.54	2.55	8.2
Kg P per Year	626	745	1073	1121	823	563	931	2993
Suspended Solids (mg/l)	5.1	8.7	7.9	10.2	9.6	7.9	7.4	40
BOD <sub>5</sub> (mg/l)	7.7	7.3	7.7	3.6	4.9	4.8	7.5	30
Ortho Phosphorus (mg/l)	0.09	0.11	0.21	0.17	0.10	0.04	0.11	N/A
Ammonia (mg/l)	7.8	13.2	20.8	10.3	13.5	10.4	4.5	N/A
Nitrate & Nitrite (mg/l)	8.8	6.5	4.4	8.7	4.9	6.7	8.7	N/A
NH <sub>4</sub> NO <sub>3</sub> NO <sub>2</sub> (mg/l)	16.6	19.6	25.1	19.0	18.4	16.7	13.1	N/A

**Table 7 - Effluent Quality Summary - Weekly**

Test Data	S.S. mg/l	BOD mg/l	Ortho P Mg/l	Total P mg/l	NH <sub>4</sub> mg/l	NO <sub>x</sub> mg/l	Oxic MLSS mg/l
January 6, 2012	6.9	N/A	0.01	0.32	8.3	4.3	3766
January 13, 2012	6.3	1.7	0.01	0.36	3.5	6.8	3662
January 20, 2012	5.6	8.0	0.14	0.51	7.9	4.6	3543
January 26, 2012	4.9	2.0	0.01	0.31	5.4	3.4	3440
February 2, 2012	5.1	6.3	0.00	0.25	8.3	3.8	3196
February 9, 2012	4.4	5.8	0.05	0.38	17.0	4.9	3045
February 16, 2012	6.8	7	0.00	0.31	5.4	4.1	3644
February 23, 2012	7.1	6.2	0.00	0.35	7.9	2.4	3729
March 1, 2012	5.8	7.8	0.01	0.45	10.0	2.5	3668
March 8, 2012	5.8	9.5	0.01	0.17	7.5	1.5	3654
March 15, 2012	7.5	9.8	0.02	1.06	8.3	2.9	3711
March 22, 2012	8.5	10.6	0.12	0.32	6.8	2.6	3794
March 28, 2012	7.1	8.1	0.59	1.09	8.7	2.8	4003
April 5, 2012	9.4	5.7	1.17	1.84	9.6	3.4	3720
April 12, 2012	11.5	10.5	0.08	0.42	11.6	3.4	4318
April 19, 2012	10.3	5.9	0.04	0.51	7.0	6.4	4035
April 25, 2012	8.9	10.0	0.07	0.54	6.7	6.0	4256
Test Data	S.S. mg/l	BOD mg/l	Ortho P Mg/l	Total P mg/l	NH <sub>4</sub> mg/l	NO <sub>x</sub> mg/l	Oxic MLSS mg/l
May 3, 2012	7.7	6.0	0.02	0.34	4.8	8.4	3965
May 10, 2012	7.5	5.9	0.04	0.34	3.5	4.2	4026
May 17, 2012	9.2	9.4	0.07	0.48	3.4	11.3	4181



City of Salmon Arm  
2012 Annual Wastewater Collection and Treatment Report

May 24, 2012	7.5	3.6	0.03	0.42	3.9	14.2	3906
May 31, 2012	6.4	N/A	0.00	0.38	2.7	10.8	3420
June 7, 2012	6.1	4.5	0.00	0.31	2.6	8.7	3938
June 13, 2012	6.6	7.2	0.02	0.34	1.8	12.9	3970
June 21, 2012	7.0	9.3	0.05	0.38	2.0	11.0	3547
June 28, 2012	5.6	8.4	0.40	1.14	2.6	12.3	3035
July 5, 2012	12.2	11.9	0.66	2.71	2.0	13.2	2950
July 12, 2012	6.0	6.6	0.73	1.98	1.2	13.0	3584
July 18, 2012	5.8	9.0	0.46	2.60	1.9	16.3	3250
July 26, 2012	5.7	7.1	0.25	1.38	1.4	17.7	4067
August 2, 2012	4.1	8.6	0.00	0.16	1.4	15.3	3233
August 9, 2012	6.2	11.5	0.00	0.22	3.7	18.0	4027
August 17, 2012	7.5	8.0	0.00	0.29	4.0	10.1	3536
August 23, 2012	4.4	4.4	0.01	0.17	2.9	12.5	3346
August 30, 2012	6.7	7.1	0.00	0.18	2.3	12.0	2958
September 6, 2012	6.3	6.5	0.00	0.31	2.7	10.7	2462
September 13, 2012	10.1	8.5	0.50	2.48	1.7	10.7	2450
September 20, 2012	10.5	9.8	0.12	0.59	2.4	7.6	3108
September 27, 2012	9.3	8.0	0.02	0.57	4.0	9.3	4550
October 4, 2012	9.5	9.7	0.02	0.44	3.4	8.2	4194
October 11, 2012	8.3	8.0	0.00	0.22	3.2	10.0	4270
October 18, 2012	8.7	6.2	0.01	0.11	2.0	9.8	4525
October 25, 2012	6.9	6.4	0.00	0.06	3.7	10.5	4083
November 1, 2012	7.9	6.8	0.00	0.25	2.9	9.2	3700
November 8, 2012	5.6	7.1	0.00	0.24	2.6	8.8	4303
November 15, 2012	8.4	9.1	0.01	0.38	2.6	8.5	4209
November 22, 2012	7.7	8.5	0.00	0.28	1.5	9.0	4340
November 30, 2012	9.1	N/A	0.00	0.26	2.7	8.5	4147
December 7, 2012	7.8	5.6	0.00	0.17	3.2	9.4	4291
December 13, 2012	8.4	5.6	0.00	0.28	1.7	9.6	4389
December 21, 2012	9.3	9.9	0.01	0.33	N/A	8.8	4230
December 27, 2012	7.7	7.6	0.00	0.28	3.1	8.5	4070
<b>Average</b>	<b>7.4</b>	<b>7.5</b>	<b>0.11</b>	<b>0.58</b>	<b>4.5</b>	<b>8.6</b>	<b>3759</b>
<b>Maximum</b>	<b>12.2</b>	<b>11.9</b>	<b>1.17</b>	<b>2.71</b>	<b>17.0</b>	<b>18.0</b>	<b>4550</b>
<b>Minimum</b>	<b>4.1</b>	<b>1.7</b>	<b>0.00</b>	<b>0.06</b>	<b>1.2</b>	<b>1.5</b>	<b>2450</b>

#### 4.4 Fecal Coliform

The ultraviolet disinfection system functioned well during 2012; however, this system will require upgrading in the near future.

#### 4.5 Toxicity

The annual toxicity test was completed on September 12, 2012 by Maxxam Analytics and once again there were no mortalities with the fish all appearing and behaving normally.

#### 4.6 Biosolids

The City of Salmon Arm produced approximately 300 dry tonnes of Class A biosolids during 2012. The biosolids are used by the Columbia Shuswap Regional District for local landfill reclamation. CARO Environmental Services conducted tests on the biosolids for nutrients,

metals and fecal coliform on November 22, 2012. Test results, once again, verified the biosolids produced by the Auto Thermophilic Aerobic Digester (ATAD) were of the highest quality in managed under the Organic Matter Recycling Regulation.

#### 4.7 Operating Certificate

The City operates the WPCC under draft Operating Certificate issued by the BC Ministry of Environment. The certificate is attached as **Appendix B**.

#### 4.8 Liquid Waste Management Plan

The City’s Liquid Waste Management Plan (LWMP) was adopted by City Council on November 2, 2004 and was subsequently approved by the Ministry of Environment (MOE). One of the commitments contained in the approved LWMP was to carry out a LWMP update during 2009 to review progress, update the schedule, and make any required revisions in consultation with MOE. The City has been working with Opus Dayton & Knight Consulting Engineer to update LWMP. In the fall of 2010 meetings were held with MOE staff in an effort to review the proposed updates and amendments. Resulting from these discussions a draft LWMP update memorandum has been prepared and submitted for MOE review and comment.

#### 4.9 WPCC Capital Projects

**Table 8 – WPCC Capital Project Information**

<b>WPCC Capital Projects completed in 2012</b>
♦ Installed Ultraviolet Odour Scrubber in Dewatering Building to assist Train A Odour Scrubber
<b>Staff Initiated WPCC Projects Completed in 2012</b>
♦ Purchased backup replacement pump for FGR recycle
♦ Purchased and installed replacement oil-less scroll air compressor ATAD Odour Scrubber
<b>WPCC Capital Projects scheduled for 2013</b>
♦ Annual Staff initiated improvements
♦ Design of ultraviolet (UV) disinfection upgrade.
♦ Pre design Trickling filter spray system

City of Salmon Arm  
2012 Annual Wastewater Collection and Treatment Report

APPENDIX A

