

GENERAL REQUIREMENTS

- All work shall conform to the requirements of the British Columbia Building Code (BCBC), 2024. All documents designated therein and all local codes and bylaws.
- The General Contractor shall compare and coordinate the drawings of all the disciplines and report any discrepancy to the Architect and the Engineers for assessment / clarification before proceeding with the work. It is assumed these drawings accurately reflect actual site conditions.
- This design has been reviewed for the adequacy of permanent primary structural components only. Excavation, soil mechanics, shoring and falsework components necessary for construction safety are not included and will not be reviewed by the structural engineer.
- The Contractor is responsible for the safety in and around the work site during construction, and for the design, erection and inspection of all temporary structure, formwork, falsework, shoring, etc. needed during construction as required by the Worker's Compensation Board (WCB).
- These structural drawings do not include the design of non-structural elements, including, but not limited to: handrails, snow retention, skylights, glazing systems, brick & stone veneer ties, and seismic restraint of mechanical and electrical equipment.
- The General Contractor must check his/her work and the work of his/her sub-trades before review by the Engineer.
- Where conflicts exist between structural documents, the strictest requirements, as indicated by the Structural Engineer, shall govern.
- No Structural member shall be cut or notched or otherwise reduced in strength unless approved by the Engineer.

SITE REVIEWS

- Site reviews of construction will be performed by the Engineer. The contractor shall give **24 HOURS NOTICE** for request of any such reviews. These reviews will be limited to concrete reinforcing steel installation, structural steelwork & decking, reinforced masonry and rough carpentry items only. They will not include site safety, methods of construction, electrical or mechanical installations.
- Safe access to jobsite is required. Scaffolding must meet WCB requirements otherwise field reviews will be denied.

DESIGN CRITERIA

- Building Code = British Columbia Building Code (BCBC) 2024
Importance Category = Post Disaster

- Dead Loads**
Roof Dead Load 20 psf

- Snow Loads**
Ground Snow Load (S_g) 73 psf
Associated Rain Load (S_R) 2.1 psf
 I_s ULS - 1.25
 I_s SLS = 0.9
Design Snow Load (S) 75.7 psf

- Live Loads**
Slab-on-Grade - Vehicle 250 psf

- Wind Loads**
 q (150) 8.4 psf
 I_w ULS 1.25
 I_w SLS 0.75

- Seismic Loading**
 S_a (0.2) 0.245
 S_a (0.5) 0.224
 S_a (1.0) 0.168
 S_a (2.0) 0.121
 S_a (5.0) 0.0608
 S_a (10.0) 0.0314
PGA 0.101
PGV 0.196
L 1.5
Rd 2.0
Ro 1.3
Moderately Ductile Walls
Seismic Category SC3
 V_{DESIGN} 13% Weight

FOUNDATIONS /SITE PREPARATIONS

- Geotechnical Report File #24.019
Date of Report March 11, 2024
Prepared by Interior Testing Services
- No foundations may be poured before materials have been approved by the Geotechnical Engineer.
- The base of the foundations shall be protected against rain, snow, frost and any other water infiltration.
- All footings shall be formed as indicated on the foundation plans in accordance with the recommendations of the Geotechnical Engineer.
- Center all footing under columns and walls unless noted otherwise.
- Footings and foundations have been designed following the design values stated in the Geotechnical Report.
SLS 3000 psf (150 kPa)
ULS 4500 psf (225 kPa)
Frost Depth 36" (900mm)
Seismic Site Class D
- Refer to Geotechnical Report for preparation of subgrade.
- For drainages of perimeter footings refer to Mechanical Drawings.
- Protect bearing surfaces from freezing before footings are poured.
- Lower footings to accommodate the mechanical and/or electrical services (refer to consultants drawings). Do not undermine the footing by excavating for services.

TEMPORARY SHORING AND BRACING

- Temporary shoring and bracing, formwork, falsework, etc. are the responsibility of the Contractor.
- These drawings show the completed structure only and not components that may be required for construction and safety during construction.
- All work shall be carried out in accordance with WorkSafe BC (or authority having jurisdiction) requirements.

CONCRETE - CAST IN PLACE

GENERAL

- The contractor shall provide minimum 24 hours notice for reinforcement inspections. Concrete shall not be poured until the reinforcing has been inspected by Willerton Engineering and final approval is obtained.
- No coring, holes, chases or embedment of pipes other than those shown on the structural drawings is permitted without written permission from Willerton Engineering.
- Mix designs shall be submitted by the contractor to the testing agency for review.
- No chlorides are permitted.
- For slabs on grade and suspended slabs, concrete is to have a curing agent (i.e. Master Seal) applied immediately after finishing the surface with a steel power trowel to a smooth and flat finish.
- Use a minimum of 4" (102mm) concrete slab-on-grade, reinforced with 10M bars @ 18" c/c (460mm) each way placed at mid-depth, UNO.
- Damp proof all walls below grade with (2) coats of asphalt emulsion, and plug tie holes with fiber-gum.
- Construction joints shall be installed at 100'-0" (30.0m) c/c maximum spacing, unless noted otherwise.
- Control joints in slab-on-grade shall be saw cut at a maximum distance of 50 times the slab thickness or 20'-0" (6.0m) whichever is less, before shrinkage cracks can form.

INSTALLATION

- All concrete placement and performance shall be in accordance with CSA-A23.1.
- No more than 2 hours shall elapse between concrete batching and concrete placement unless approved by the testing agency. No water should be added after initial batching. These items are to be monitored by the Contractor.
- Concrete should be protected at all times from being damaged during construction.
- All concrete shall be compacted with mechanical vibrators.
- Formed concrete shall be cured for a minimum of 7 days prior to stripping of formwork.

TESTING

- Concrete testing shall be done by a testing laboratory at the Owner's expense. Concrete testing shall be conducted for every 70 cubic yards of concrete, but not less than 1 test for concrete cast each day.

CONCRETE MIX DESIGN:					
LOCATION	28 Day Strength (MPa)	Air Content (%)	Water Cement Ratio	MAX. AGGREGATE SIZE: 3/4" (20mm)	
EXTERIOR	Footings Perimeter	30	1 to 3		0.55
	Walls Perimeter	30	4 to 7		0.55
	Retaining walls	30	5 to 8		0.55
	Slab(s) on grade	30	5 to 8		0.45
	Piles and piers	30	5 to 8		0.55
	Slabs, beams, columns	35	5 to 8		0.40
INTERIOR	Steel decking (Fill)	30	5 to 8		0.55
	Footings	30	1 to 3		-
	Walls	30	1 to 3		-
	Slab(s) on grade	30	1 to 3	-	
Slabs, beams, columns	35	1 to 3	0.40		
Steel decking (Fill)	30	1 to 3	0.55		
The concrete mix shall be in conformance with CSA A23.1 Strength, water cement ratio, and air content shall conform to Tables 7, 8 & 9 of CSA A23.1					

COLD WEATHER REQUIREMENT

- Forecasted temperature no below 2°C:
 - If concrete drops below 10°C at point of pouring, the mixing water shall be heated to maintain a minimum concrete temperature of 10°C.
 - Concrete shall not be placed on or against any surface which is at temperatures less than 4°C.
 - Contractor should be prepared to cover concrete pour if unexpected weather occurs.
- Forecasted temperature below 2°C but above -4°C:
 - Forms and steel should be free of ice and snow.
 - Mixing water shall be heated to give a minimum concrete temperature of 10°C at point of pour.
 - Concrete shall not be placed on or against any surface which is at temperatures less than 4°C.
- Forecasted temperature below -4°C:
 - Forms and steel should be free of ice and snow.
 - Mixing water shall be heated to give a minimum concrete temperature of 10°C at point of pour.
 - Concrete shall not be placed on or against any surface which is at temperatures less than 4°C.
 - Poured concrete shall be covered with canvas or similar and kept a few inches from the surface.
 - Temperature of the concrete at all surfaces shall be kept at minimum of 20°C for 3 days, or 10°C for 5 days. The concrete must be kept above freezing for a minimum of 7 days.
 - The enclosure must be constructed so that air can circulate outside the outer of edge members.

REINFORCING STEEL

GENERAL

- Detail and place reinforcing steel in accordance with the "Reinforcing Steel Manual of Standard Practice" and CSA-A23.1 unless noted otherwise.
 - Provide deformed bars with yield strength of 400 MPa as specified in CSA G30.18.
 - Provide welded wire fabric as specified in CSA G40.20/G40.21.
 - Provide a minimum of (2) 15M bars extending 2'-0" (610mm) beyond all corners at wall and slab openings greater than 2'-0" (610mm) wide.
- INSTALLATION
- Reinforcing steel is to be free of all dirt, excessive rust and scale at the time of placing and is to be securely in place prior to placing any concrete. No bars are to be wet doveled with the exception of anchor bolts.
 - All bars shown as being bent on the drawings are to be machine bent prior to being placed.
 - Concrete cover and bar splices are to be as indicated or in accordance with N.B.C.
 - The minimum clear cover for reinforcement in non-pre-stressed concrete with expose to earth or weather shall be as shown on the drawings.
 - Reinforcing steel which requires splicing must have a minimum lap of 40 bar diameters. Bars must be continuous around corners and at intersections of walls, either by bending around the corner, or by adding corner bars with the minimum 40 bar diameter lap length. Space laps so that no more than 50% of bars placed are lapped within 4'-0" (1200mm) for beams and columns.
 - Provide a minimum of (2) 15M bars extending 2'-0" (610mm) beyond all corners at wall and slab openings greater than 2'-0" (610mm) wide.
 - All wall and grade beam reinforcing shall be continuous at corners and intersections. Use corner bars.
 - Provide chairs, spacer bars, support bars & other accessories to support reinforcing in accordance with the latest editions of CSA A23.1 and A23.3

Min. reinforcing bar lap / splice U.N.O.:					
Bar Size	Inches	mm	Bar Size	Inches	mm
10M	16"	410	20M	36"	915
15M	24"	610	25M	44"	1200

WOOD

- All materials shall be kept dry and protected from the environment at all times.
- No cutting or notching of members without the approval from the Structural Engineer.

DIMENSIONAL LUMBER

- All sawn lumber is to conform to CAN/CSA O141.
- All dimensional lumber shall be graded in accordance with the National Lumber Grades Authority.
- All dimensional lumber shall be dry with a maximum moisture content of 12%.
- All dimensional lumber shall be SPF No. 2 or better unless noted otherwise.
- Wood in contact with concrete or masonry shall be pressure treated or separated from contact with a moisture barrier.

STRUCTURAL COMPOSITE LUMBER (SCL)

- All manufactured beams are to be minimum 2.0E/2900Fb unless noted otherwise & identified with a stamp indicating the product type and grade.
- Laminated veneer lumber (LVL) and parallel strand lumber (PSL) shall conform to CSA-086

SHEATHING (Plywood and Oriented Strand Board)

- All floor, roof and wall sheathing shall be plywood conforming to CAN/CSA O121 or CAN/CSA O151 or; Oriented Strand Board (OSB) to CAN/CSA O325.
- Sheathing shall be fastened directly to the supporting framing with the face grain oriented perpendicular to the framing.
- Panel edges and openings shall be reinforced with back framing, H-clips or tongue and groove.

BUILT-UP BEAMS

- Typical beam fastening unless noted otherwise:

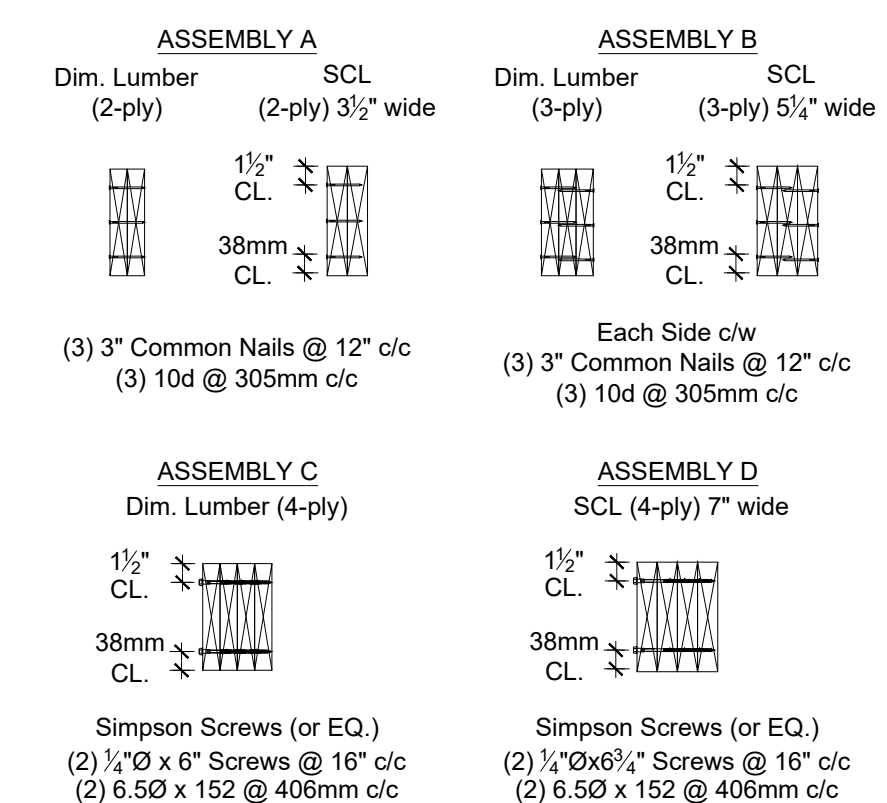

- All Rows to be Staggered
- Additional row of fasteners required for beam depths >14" (356mm)

BUILT-UP COLUMNS

- (2) ply built-up columns shall be fastened together with minimum (2) rows of 3" (75mm) common nails @ 9" (230mm) c/c alternating face or (1) row for 2x4 (28x89mm) lumber.
- (3) ply built-up columns shall be fastened together with minimum (2) rows of 4 1/2" (115mm) common nails @ 9" (230mm) c/c alternating face. or (1) row for 2x4 (28x89mm) lumber.
- (4) ply built-up columns shall be fastened together with minimum (2) rows of 6" (150mm) common nails @ 9" (230mm) c/c alternating face.
- (5) ply built-up columns shall be fastened together with minimum (1) 1/2" (113mm) Ø bolt @ 12" (305mm) c/c unless noted otherwise.
- Equivalent length 1/2" (6mm) Ø structural screws (GRK or Simpson) may be used in place of common nails.

TRUSSES (prefabricated wood truss systems)

- The design of trusses shall be done by a Specialty Professional Engineer registered in the province of British Columbia, familiar with wood design.
- The Truss Engineer shall design, prepare shop drawings, review fabrication, review field installation and provide a sealed Schedule S-B and S-C to Willerton Engineering for the trusses and support framing including lateral bracing, bridging, bearing plates, connecting hardware, hold downs and tension ties.
- Prefabricated wood trusses shall be designed and fabricated in accordance with the latest edition of the British Columbia Building Code, the Truss Plate Institute of Canada, CAN/CSA 084 and these drawings.
- Trusses shall be designed by the Truss Engineer for truss reactions not to exceed the design bearing capacity of SPF No. 2 perpendicular to grain, 2x8 (38x140mm) for exterior wall or 2x4 (28x89mm) for interior wall UNO.
- An unfactored live load of 300 lbs. (136.1 kg.) down shall be applied to any location along the truss bottom chord.
- All bracing to be shown on the truss drawings & designed by the Truss Engineer.
- Mark numbers shall be shown on the truss bottom chords.
- The truss supplier shall include all fasteners to the base structure for all loads specified.
- The truss drawings shall include all necessary information required for correct installation without reference to further drawings or instructions.
- Trusses are to be cambered for 1/2 live load and full dead load. Trusses with more than (2) bearing points are to be fabricated with no camber for level bearing.
- The contractor shall coordinate all mechanical loads, duct openings, curb sizes and roof top unit locations with the Truss and Mechanical Designers.
- Changes to the roof truss layouts as indicated on Willerton Engineering's drawings are not permitted without prior written consent of Willerton Engineering. Any costs incurred by Willerton Engineering associated with reviewing alternate framing schemes shall be paid by the Contractor.
- The Contractor shall notify the Truss Engineer for field reviews of truss installations, prior to sheathing the ceiling.
- Trusses shall be connected to top plates with Simpson Strong-Tie 'H' series ties, unless noted otherwise.

TILT-UP PANELS

GENERAL

- All tilt-up concrete wall panels shall comply with CSA standard A23.3-04 "design of concrete structures", comply with all sections in this code and references therefrom for the design, manufacture, handling and erection of all tilt-up units.
- Internal faces shall be steel trowelled.
- The contractor shall check all dimension lines and levels on the job before fabrication to ensure that all sizes are absolutely correct and conform to the foundations as constructed.
- The contractor shall prepare and submit to the owner's representative for review such design necessary for panel lifting, shoring, fabrication and installation. These drawings shall be prepared and submitted by a professional engineer registered in the province of British Columbia.
- Forms shall conform to the shape, lines and dimensions of the work as called for on the drawings.
- It is the intention of this contract that all tilt-up concrete wall members be similar in appearance, colour, and finish. Any distinct variation from this intended uniformity, in the opinion of the owner's representative, shall be cause for rejection and the member shall be replaced at the contractor's expense.
- The tilt-up concrete wall panel lifting design shall provide reinforcing as required for the purpose of handling on site during erection without damage.
- The contractor shall be responsible for the supply and installation of all connection devices and steelwork including steel inserts, etc., placed on site for connection of tilt-up concrete wall panel units.
- The contractor shall submit shop drawings of all tilt-up concrete wall panels to Willerton Engineering for review and approval prior to fabrication. Shop drawings shall show all details, including design loads, material specifications, embedded mechanical items, cambers and connections. Shop drawings shall be sealed by a Professional Engineer and letters of assurance (Schedules S-B and S-C) provided to Willerton Engineering.
- Connectors shall provide ample strength as well as adjustment during erection.
- All connections must be welded by a CWB certified welder.
- Minor damage to surfaces during handling or erection may be repaired providing the repair is equivalent, in the opinion of the owner's representative, to the original in appearance and permeance.
- Erection of all tilt-up concrete wall panels shall be carried out by skilled tradesmen applying only the best trade practices in all phases of the erection work under the continuous supervision of fully qualified superintendents.
- All tilt-up concrete wall panels shall be erected square, true and plumb and be installed in place without forcing or any other such manner as to induce or impose any undue stresses or loads onto any part of the building, units or hardware.
- Erection of tilt-up wall panels shall comply with Worksafe BC requirements.
- Where a reinforcing bar is interrupted by a pocket in panel provide a matching bar of the same diameter to either side of pocket.
- Field welding of all embedded metal connectors by steel erector UNO.
- Contractor to ensure that a suitable bond breaker is to be used when fabricating the tilt-up concrete wall panels and that said bond breaker is compatible with any future architectural finishes per the Architect's requirements.

DRAWING INDEX

S0.1	PROJECT NOTES DRAWING INDEX
S1.1	FOUNDATION PLAN
S1.2	FOUNDATION DETAILS
S1.3	FOUNDATION DETAILS
S2.1	ROOF FRAMING PLAN
S2.2	ROOF FRAMING DETAILS



**WILLERTON
ENGINEERING**

4408 28th STREET, VERNON, B.C.
Phone : 250-542-5454
email : admin@willerton.ca
web : willerton.ca

COPYRIGHT 2024
WILLERTON ENGINEERING

CONSULTANTS

REVISIONS

NO.	DATE	DESCRIPTION
A	240503	COORDINATION
B	240712	TENDER

PROJECT

**PROPOSED
ADDITION
OPTION 'B'**

FOR

**CITY OF
SALMON ARM
FIRE HALL #2
TRUCK BAY
ADDITION**

200 - 30th STREET SE
SALMON ARM, BC

DRAWING

**PROJECT
NOTES**

**DRAWING
INDEX**

FILE
23-400

DATE
12 JULY 2024

SCALE
1/4" = 1'-0"

DESIGN
BH

ENGINEER
CW

SEAL

PERMIT TO PRACTICE No. 1001581

SHEET NUMBER REV

S0.1 B

FOUNDATION NOTES

1. DOWELS CANNOT BE WET SET AND MUST BE MACHINE BENT.
2. SPLICE BARS REQUIRED IN ALL WALL CORNERS/INTERSECTIONS, U.N.O.
3. ALL DOWELS ALTERNATE DIRECTION OF HOOKS INTO FOOTING, U.N.O.
4. ALL DOWELS TO HAVE MINIMUM 2'-0" PROJECTION ABOVE FOOTING, U.N.O.

FOUNDATION WALL TYPES

FW1	<p>NEW 10" WIDE CONCRETE FOUNDATION WALL</p> <ul style="list-style-type: none"> (2) 15M CONTINUOUS TOP BARS 15M HORIZONTAL BARS @ 16" c/c 15M VERTICAL BARS @ 16" c/c 15M FOOTING DOWELS @ 16" c/c 8" LONG ALTERNATING HOOKS + MINIMUM 24" PROJECTION PAST TOP OF FOOTING ALL WALL STEEL PLACED IN CENTER OF WALL <p>24" WIDE x 10" DEEP CONCRETE STRIP FOOTING</p> <ul style="list-style-type: none"> (3) 15M CONTINUOUS BARS OR PAD FOOTING PER PLAN 10M LATERAL BARS @ 16" c/c
FW2	<p>NEW 10" WIDE CONCRETE FOUNDATION WALL</p> <ul style="list-style-type: none"> (2) 15M CONTINUOUS TOP BARS 15M HORIZONTAL BARS @ 16" c/c 15M VERTICAL BARS @ 16" c/c 15M FOOTING DOWELS @ 16" c/c 8" LONG ALTERNATING HOOKS + MINIMUM 24" PROJECTION PAST TOP OF FOOTING ALL WALL STEEL PLACED IN CENTER OF WALL <p>24" WIDE x 10" DEEP CONCRETE STRIP FOOTING</p> <p>TOP LAYER REINFORCING</p> <ul style="list-style-type: none"> PLACED 3" CLEAR TOP OF EXISTING FOOTING (3) 15M CONTINUOUS BARS OR PAD FOOTING PER PLAN 10M LATERAL BARS @ 24" c/c DRILL + EPOXY TO FACE OF EX. FOUNDATION WALL w/ HILTI HY-200 EPOXY EMBED 5" <p>BOTTOM LAYER REINFORCING</p> <ul style="list-style-type: none"> PLACED MID-HEIGHT OF EXISTING FOOTING (2) 10M CONTINUOUS BARS 10M LATERAL BARS @ 24" c/c DRILL + EPOXY TO FACE OF EXISTING FOOTING w/ HILTI HY-200 EPOXY EMBED 5"
FW3	<p>EXISTING 8" WIDE CONCRETE FOUNDATION WALL</p>

PAD FOOTING TYPES

PF1	<p>4'-0"x4'-0"x10" THICK CONCRETE PAD FOOTING c/w (5) 15M BARS EACHWAY, CHAIRED 3" CLEAR OF GRADE</p>
PF2	<p>5'-0"x3'-0"x10" THICK CONCRETE PAD FOOTING</p> <p>TOP LAYER REINFORCING</p> <ul style="list-style-type: none"> PLACED 3" CLEAR TOP OF EXISTING FOOTING (6) 15M SHORT DIRECTION BARS (4) 15M LONG DIRECTION BARS <p>BOTTOM LAYER REINFORCING</p> <ul style="list-style-type: none"> PLACED MID-HEIGHT OF EXISTING FOOTING (6) 15M SHORT DIRECTION BARS (4) 15M LONG DIRECTION BARS
PF3	<p>3'-0"x3'-0"x10" THICK CONCRETE PAD FOOTING</p> <p>TOP LAYER REINFORCING</p> <ul style="list-style-type: none"> PLACED 3" CLEAR TOP OF EXISTING FOOTING (4) 15M BARS EACHWAY <p>BOTTOM LAYER REINFORCING</p> <ul style="list-style-type: none"> PLACED MID-HEIGHT OF EXISTING FOOTING (4) 15M SHORT DIRECTION BARS (3) 15M LONG DIRECTION BARS

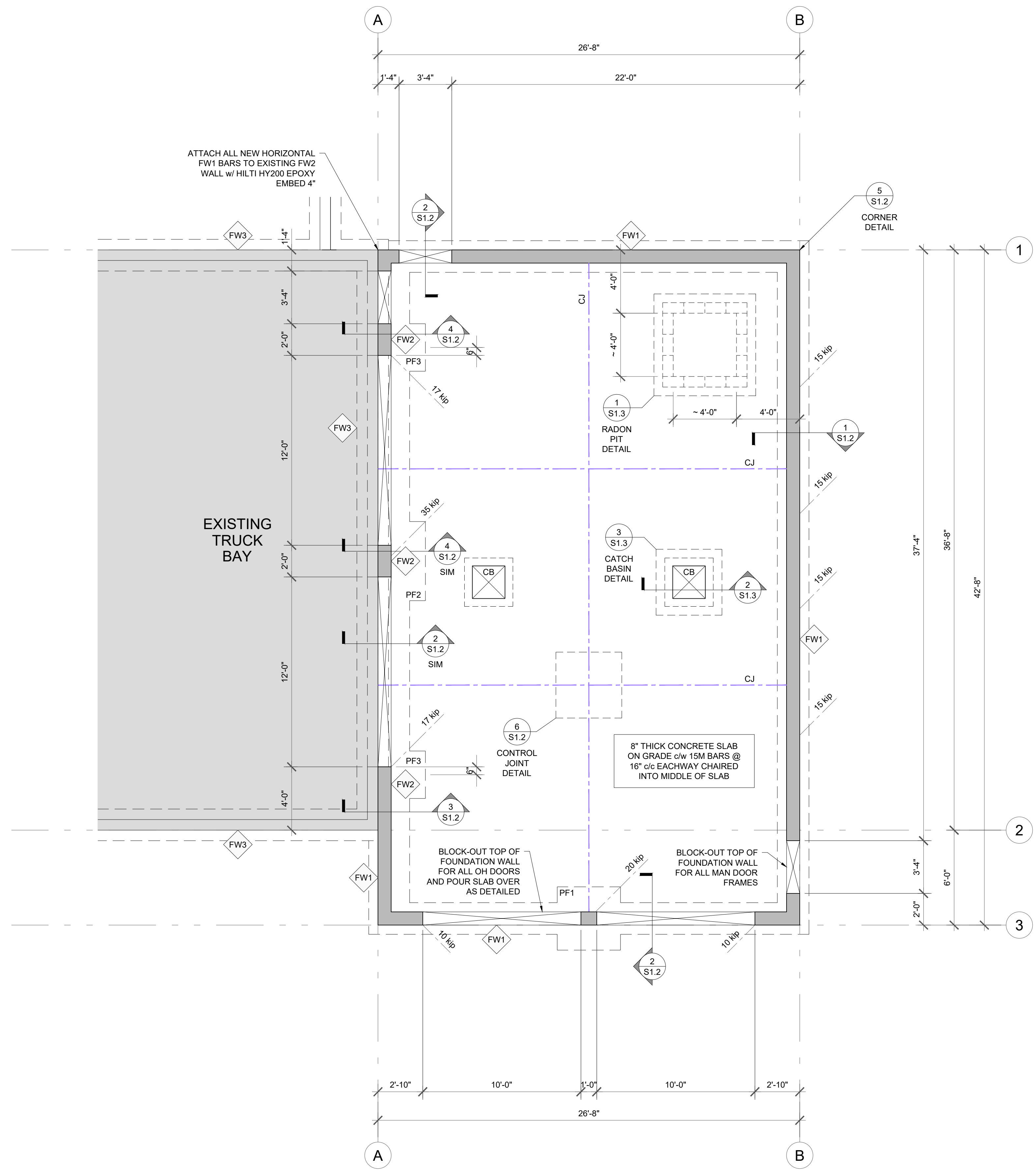

1 FOUNDATION PLAN
SCALE: 1/4"=1'-0"

REVISIONS

NO.	DATE	DESCRIPTION
A	240503	COORDINATION
B	240712	TENDER

PROJECT
PROPOSED ADDITION OPTION 'B'
FOR
CITY OF SALMON ARM FIRE HALL #2 TRUCK BAY ADDITION
200 - 30th STREET SE
SALMON ARM, BC

DRAWING
FOUNDATION PLAN

FILE
23-400
DATE
12 JULY 2024
SCALE
1/4" = 1'-0"
DESIGN
BH
ENGINEER
CW
SEAL

PERMIT TO PRACTICE No. 1001581

SHEET NUMBER
S1.1
REV
B

REVISIONS

NO.	DATE	DESCRIPTION
A	240503	COORDINATION
B	240712	TENDER

PROJECT

PROPOSED ADDITION OPTION 'B'

FOR

**CITY OF SALMON ARM
 FIRE HALL #2
 TRUCK BAY ADDITION**

200 - 30th STREET SE
 SALMON ARM, BC

DRAWING

FOUNDATION DETAILS

FILE
 23-400

DATE
 12 JULY 2024

SCALE
 3/4" = 1'-0"

DESIGN
 BH

ENGINEER
 CW

SEAL

PERMIT TO PRACTICE No. 1001581

SHEET NUMBER REV

S1.2 B

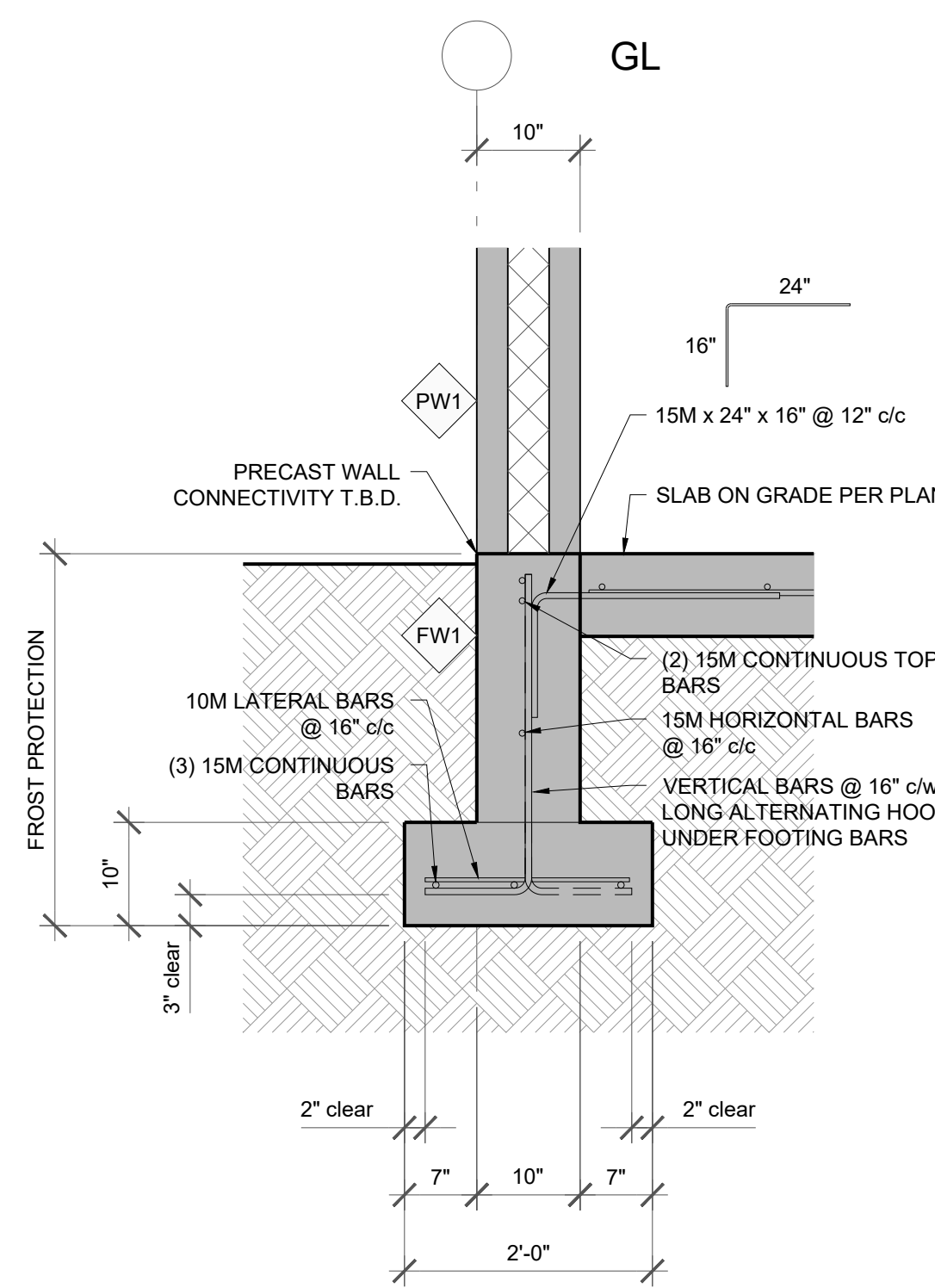

1 FOUNDATION DETAIL FW1
 S1.1 SCALE: 3/4"=1'-0"

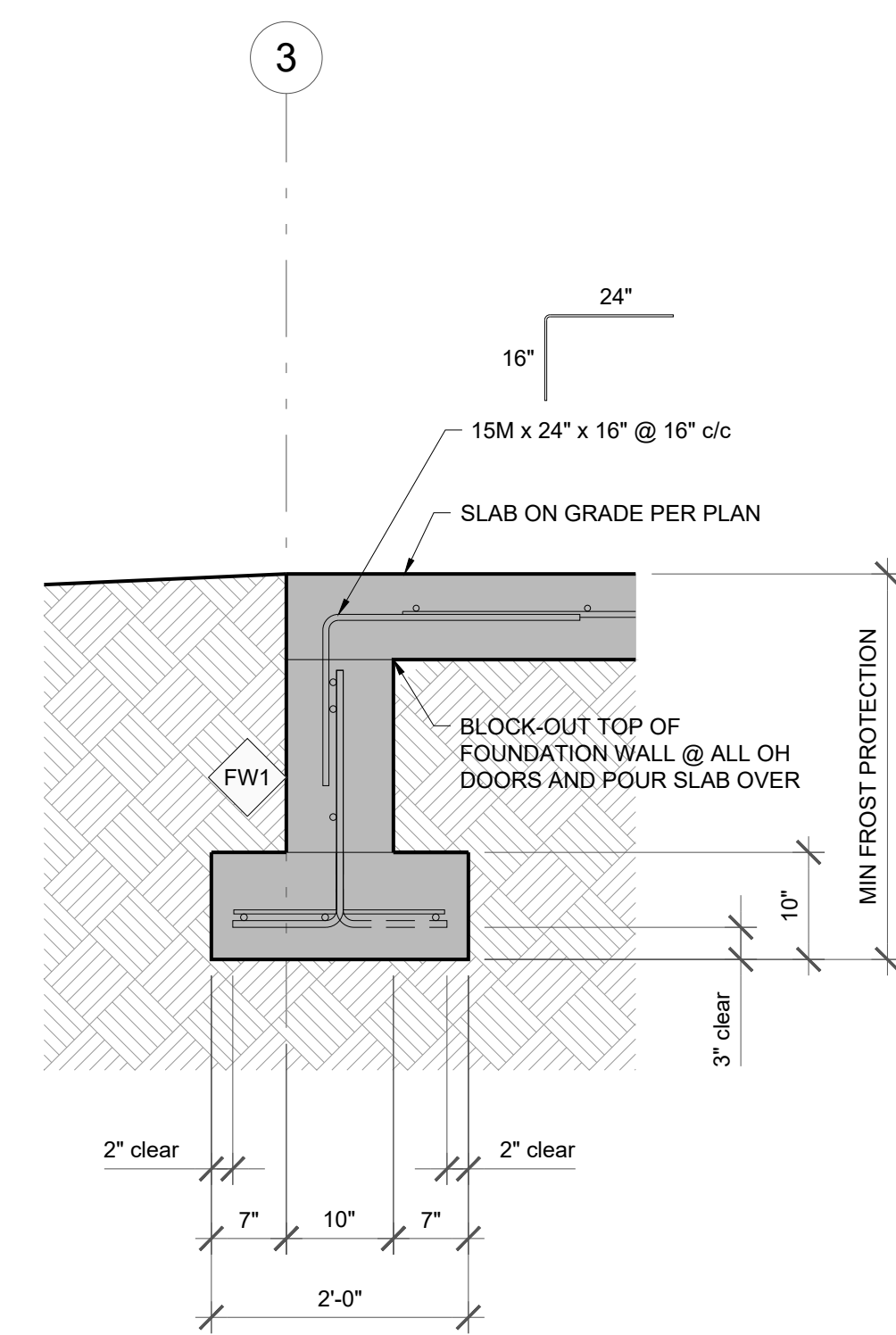

2 FOUNDATION DETAIL FW1
 S1.1 SCALE: 3/4"=1'-0"

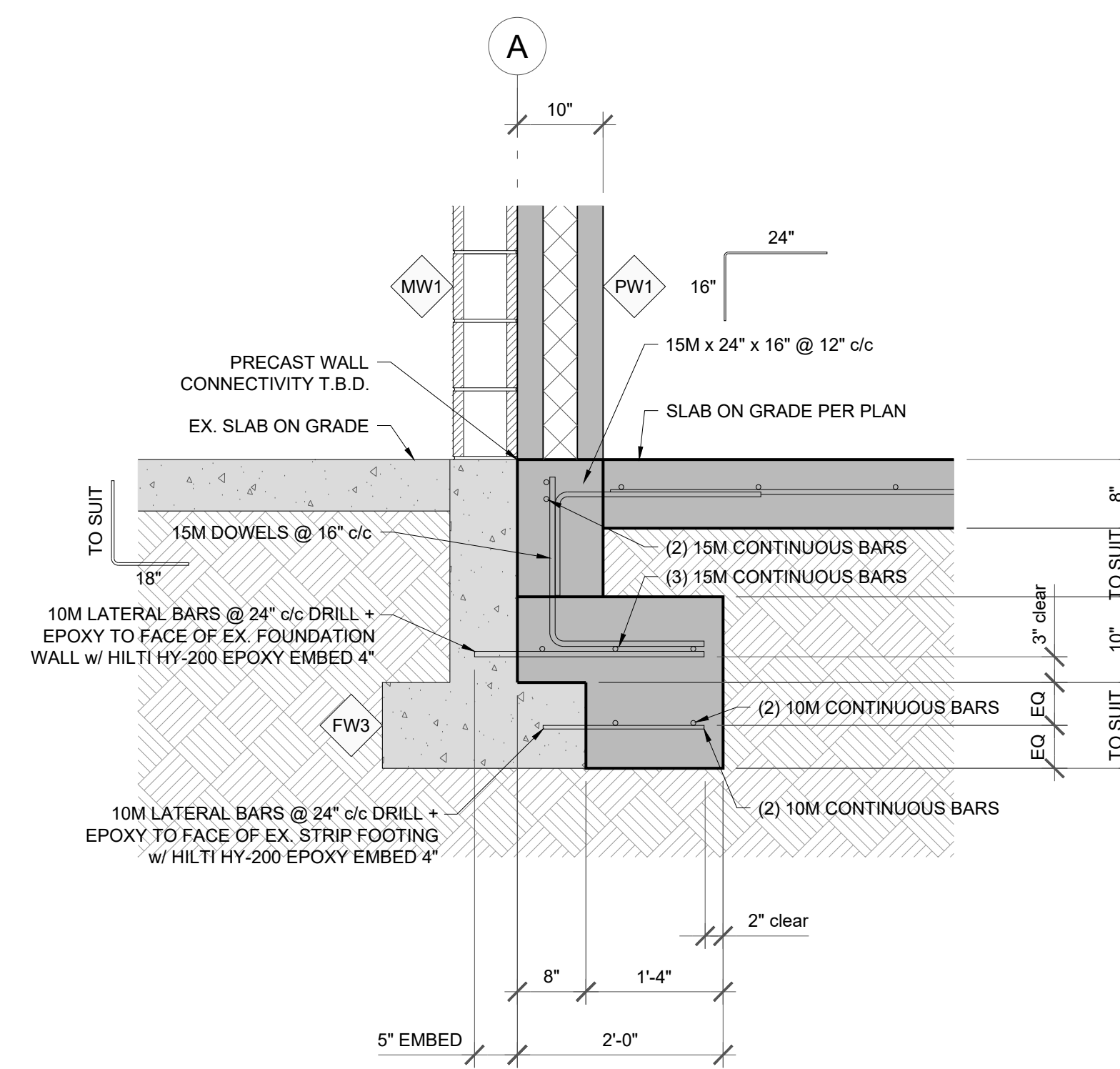

3 FOUNDATION DETAIL FW2
 S1.1 SCALE: 3/4"=1'-0"

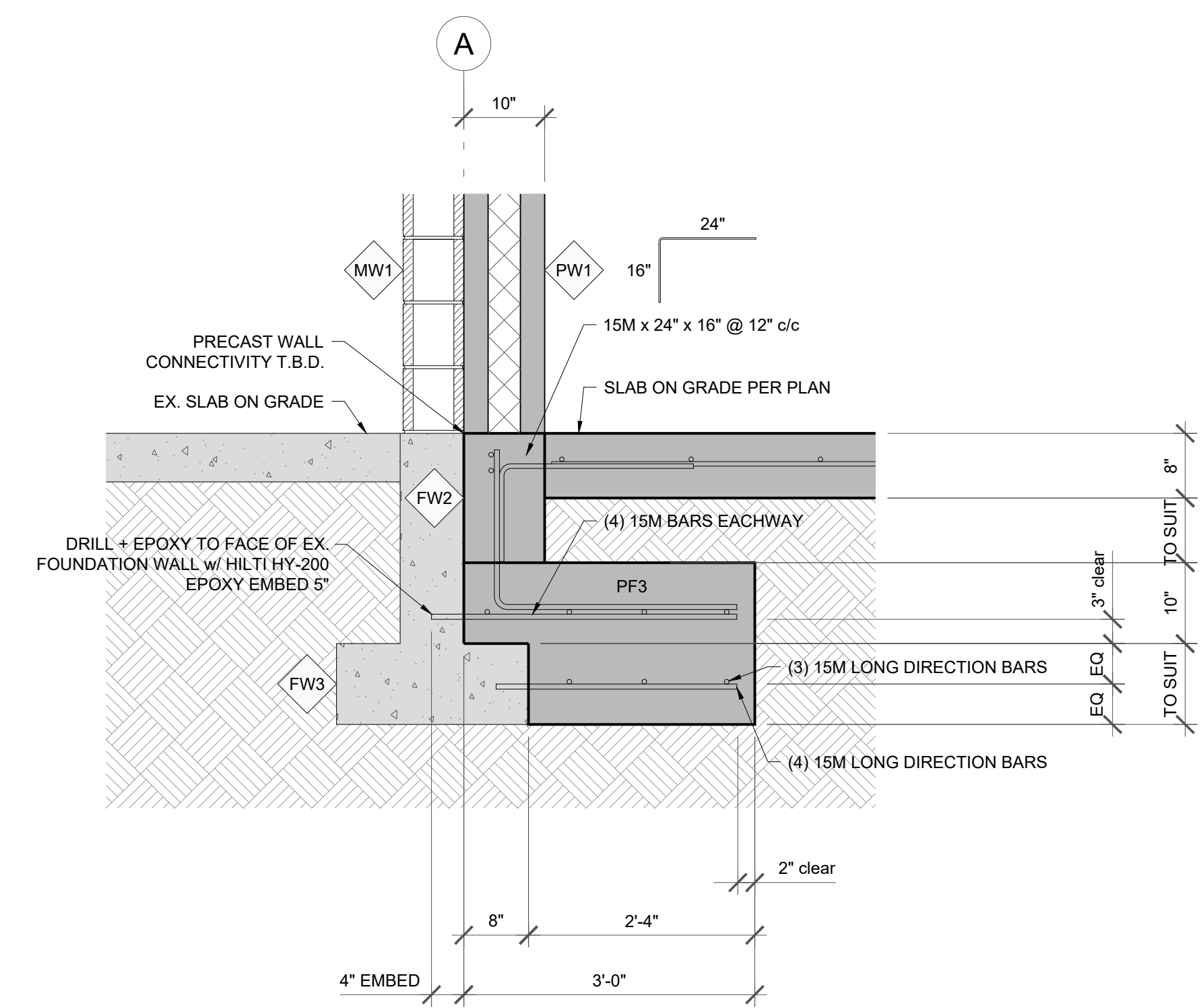

4 FOUNDATION DETAIL FW2 / PF3
 S1.1 SCALE: 3/4"=1'-0"

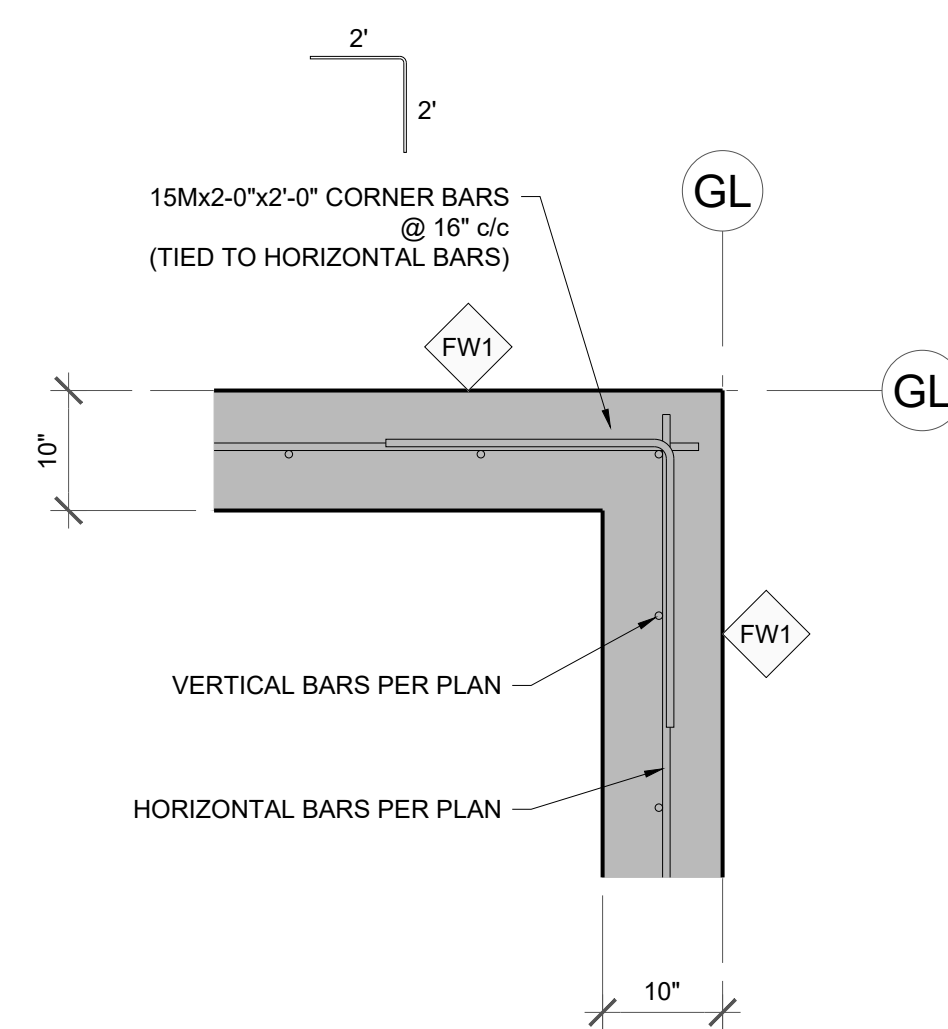

5 TYPICAL CORNER DETAIL U.N.O.
 S1.1 SCALE: 3/4"=1'-0"

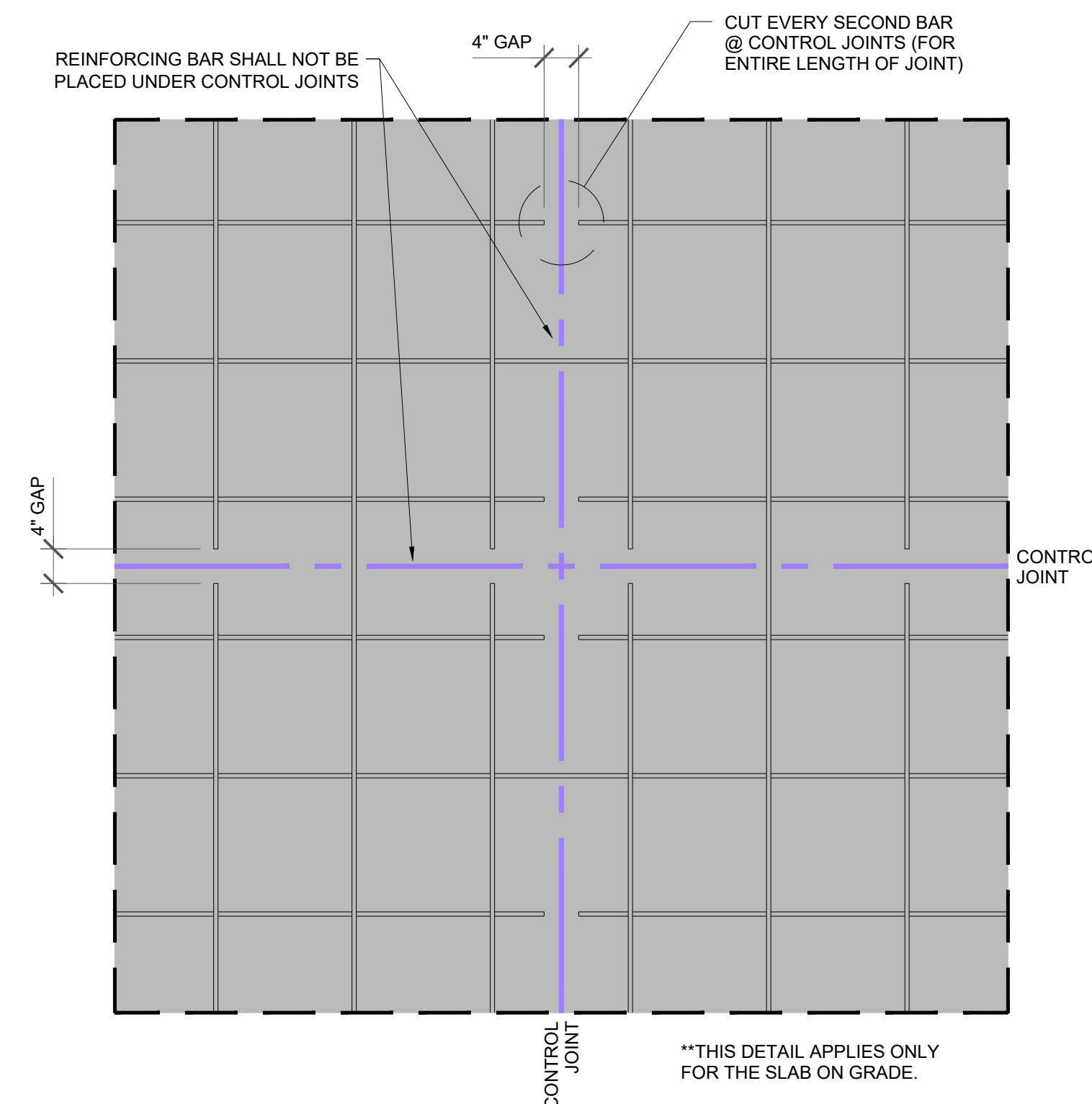

6 TYPICAL SLAB ON GRADE CONTROL JOINT DETAIL
 S1.1 SCALE: 3/4"=1'-0"

**THIS DETAIL APPLIES ONLY FOR THE SLAB ON GRADE.

REVISIONS

NO.	DATE	DESCRIPTION
A	240503	COORDINATION
B	240712	TENDER

PROJECT

**PROPOSED
ADDITION
OPTION 'B'**

FOR

**CITY OF
SALMON ARM
FIRE HALL #2
TRUCK BAY
ADDITION**

200 - 30th STREET SE
SALMON ARM, BC

DRAWING

**FOUNDATION
DETAILS**

FILE
23-400

DATE
12 JULY 2024

SCALE
3/4" = 1'-0"

DESIGN
BH

ENGINEER
CW

SEAL

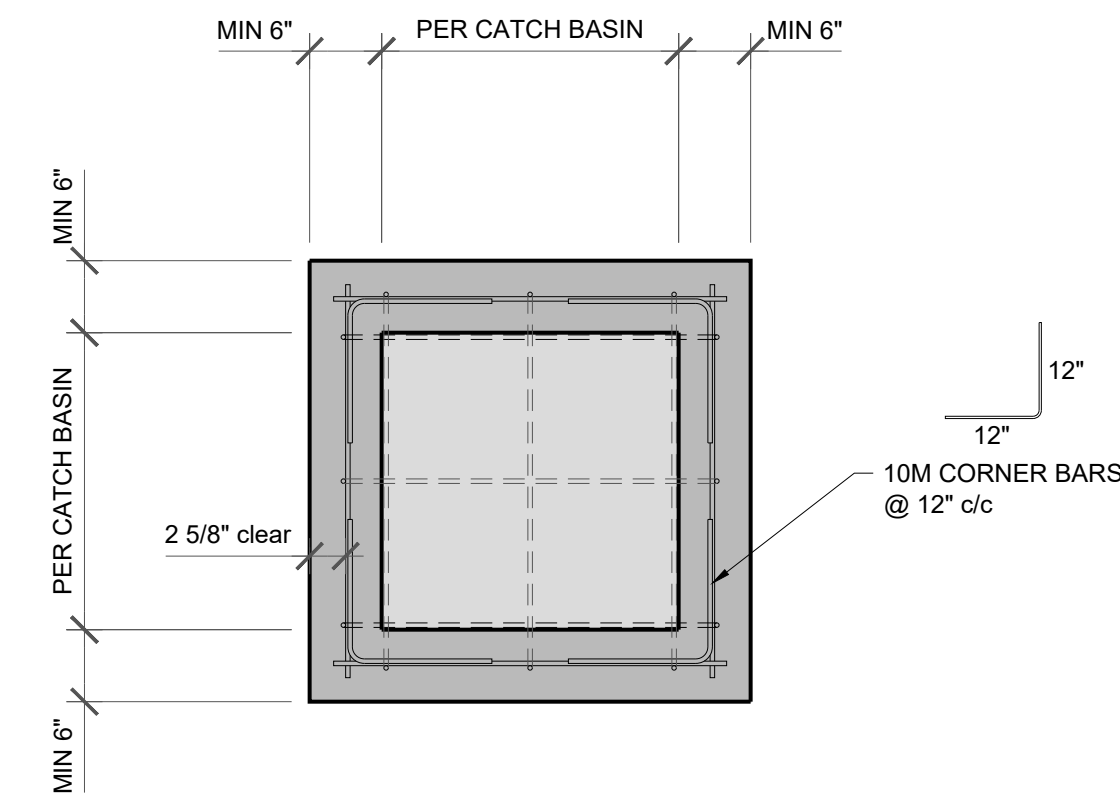

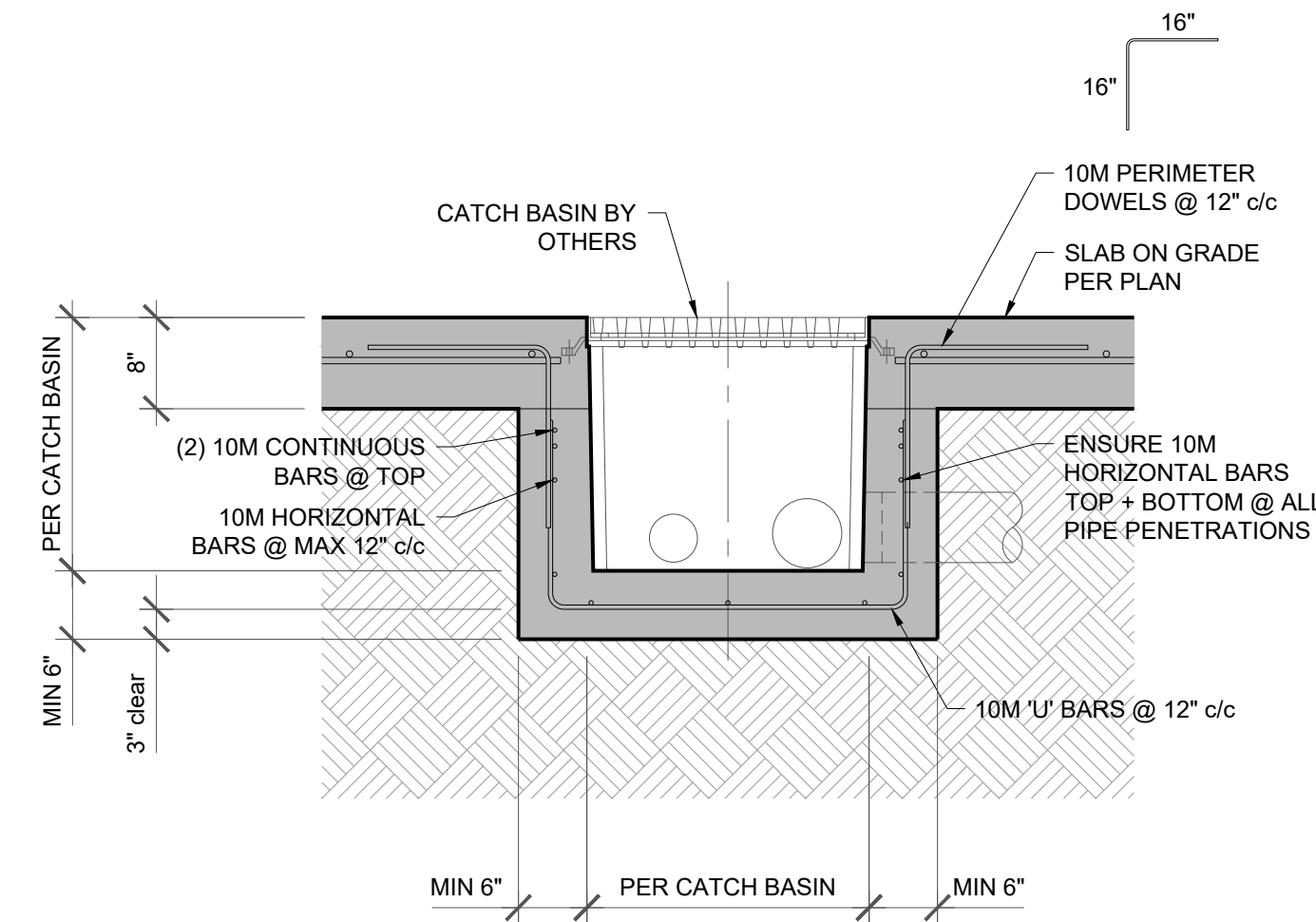

3 CATCH BASIN DETAIL
S1.1 SCALE: 3/4"=1'-0"



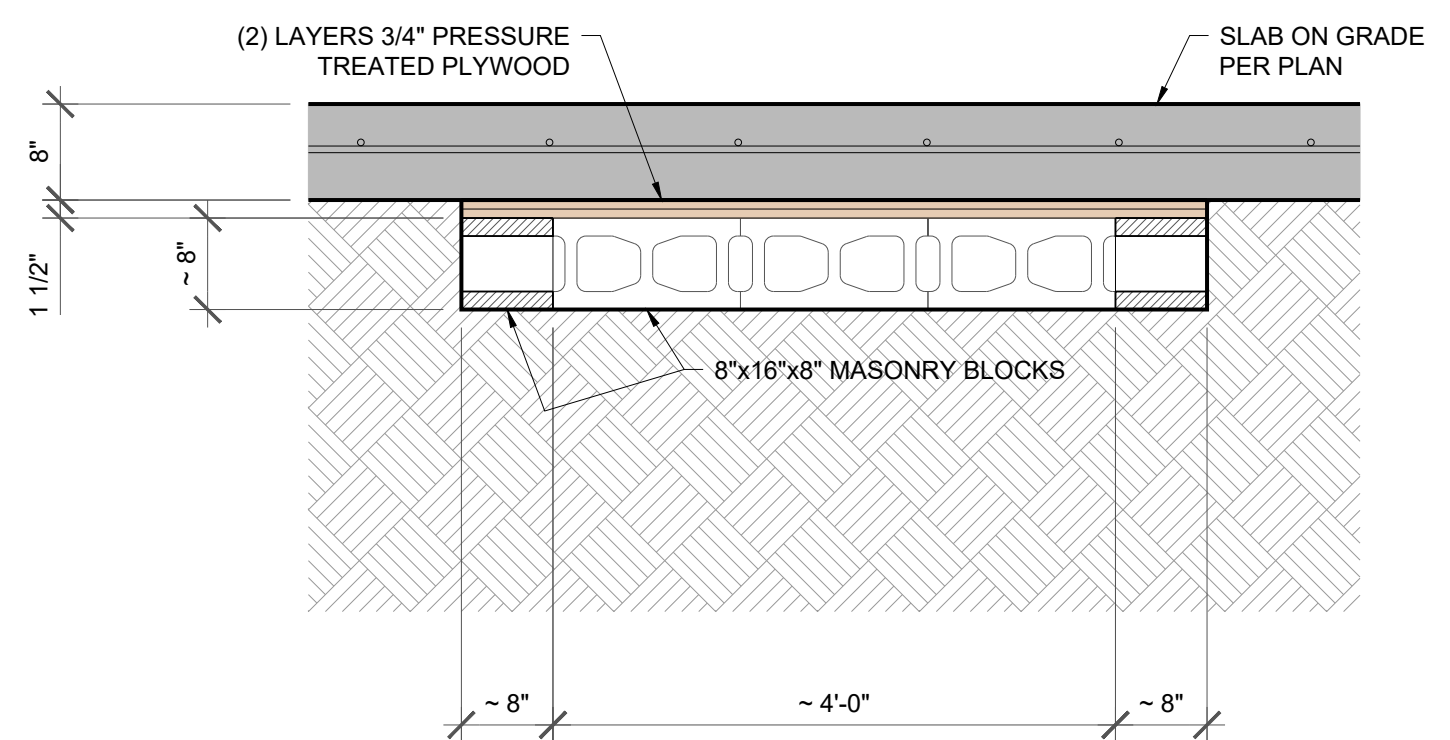

2 CATCH BASIN DETAIL
S1.1 SCALE: 3/4"=1'-0"



1 RADON PIT DETAIL
S1.1 SCALE: 3/4"=1'-0"

WALL TYPES	
	PRECAST CONCRETE WALLS - BY OTHERS
	EXISTING 8" SPLIT FACE MASONRY BLOCK WALL

ROOF ASSEMBLIES	
	MAIN FLAT ROOF FRAMING - ENGINEERED WOOD ROOF TRUSSES PER MANUFACTURER - MIN 5/8" T&G PLYWOOD SHEATHING SECURED TO JOISTS w/ 2 1/2" COMMON NAILS @ 6" c/c MAX SPACING
	EXISTING ROOF FRAMING - STEEL ROOF DECKING ON ARCHED STEEL ROOF BEAMS

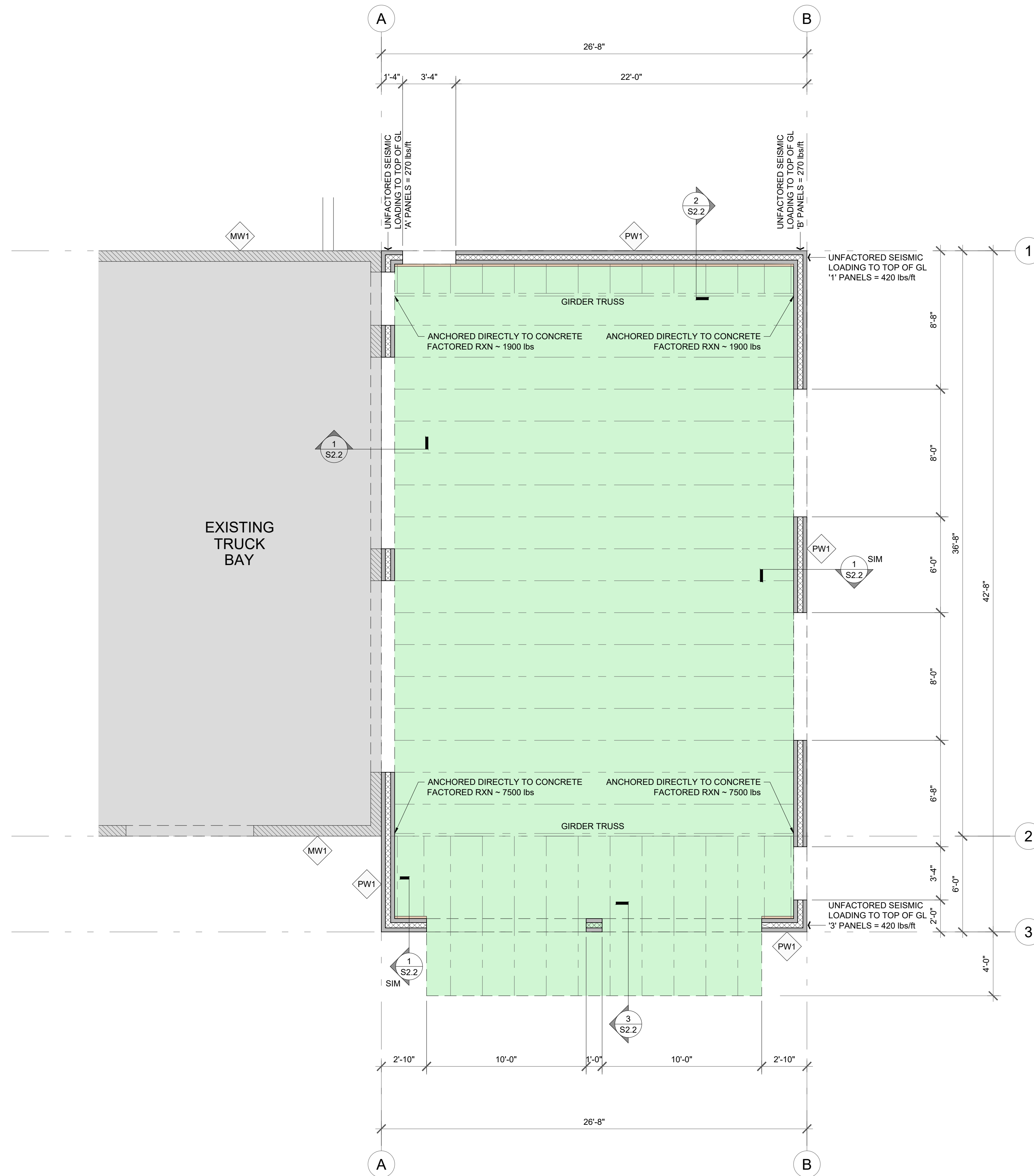

1 ROOF FRAMING PLAN
SCALE: 1/4"=1'-0"

REVISIONS		
NO.	DATE	DESCRIPTION
A	240503	COORDINATION
B	240712	TENDER

PROJECT
**PROPOSED
ADDITION
OPTION 'B'**
FOR
**CITY OF
SALMON ARM
FIRE HALL #2
TRUCK BAY
ADDITION**
200 - 30th STREET SE
SALMON ARM, BC

DRAWING
**ROOF FRAMING
PLAN**

FILE
23-400
DATE
12 JULY 2024
SCALE
1/4" = 1'-0"
DESIGN
BH
ENGINEER
CW
SEAL

PERMIT TO PRACTICE No. 1001581

SHEET NUMBER	REV
S2.1	B

REVISIONS

NO.	DATE	DESCRIPTION
A	240503	COORDINATION
B	240712	TENDER

PROJECT

**PROPOSED
ADDITION
OPTION 'B'**

FOR

**CITY OF
SALMON ARM
FIRE HALL #2
TRUCK BAY
ADDITION**

200 - 30th STREET SE
SALMON ARM, BC

DRAWING

**FOUNDATION
DETAILS**

FILE

23-400

DATE

12 JULY 2024

SCALE

1" = 1'-0"

DESIGN

BH

ENGINEER

CW

SEAL

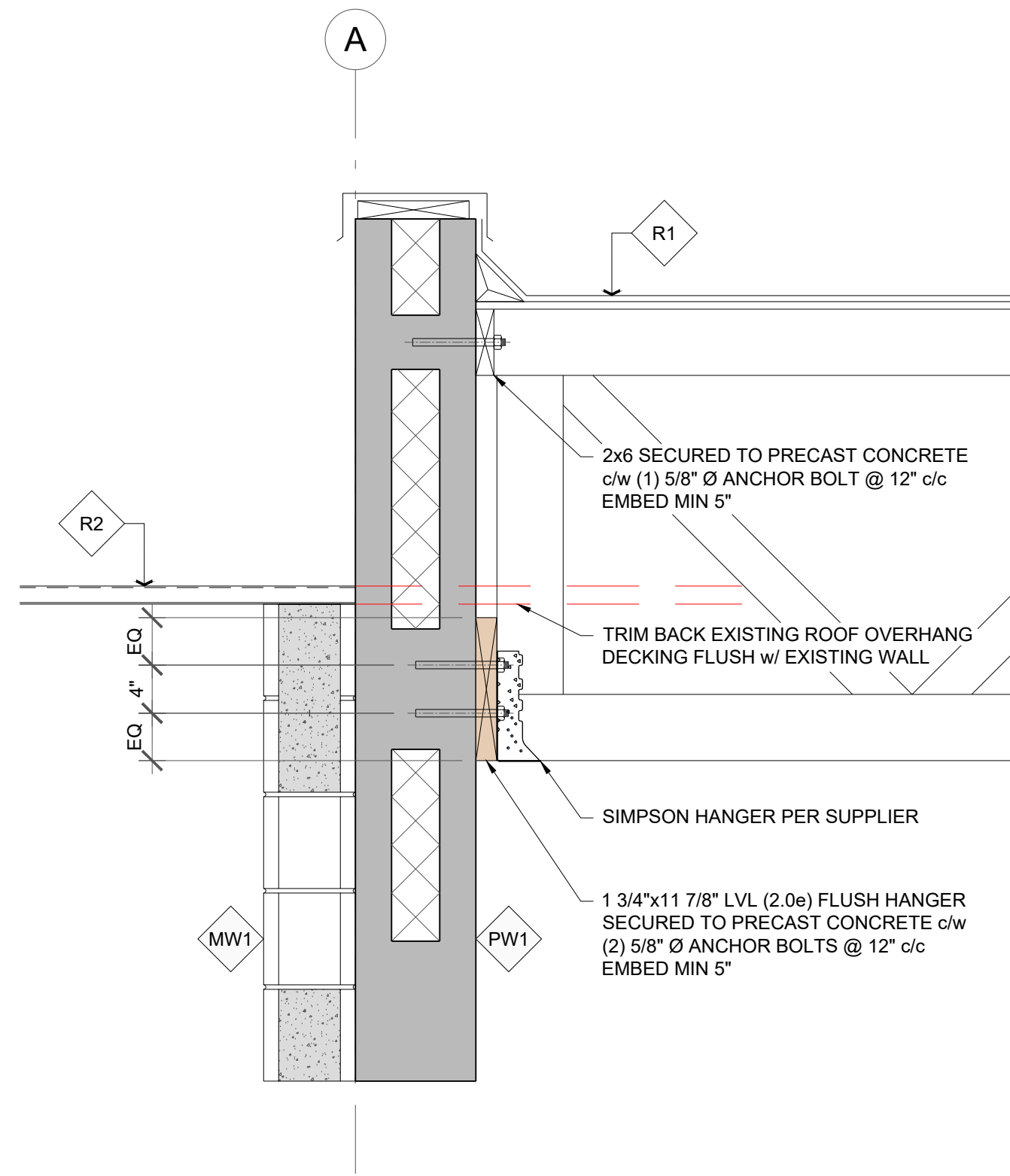

1 ROOF FRAMING DETAIL

S2.1 SCALE: 1"=1'-0"

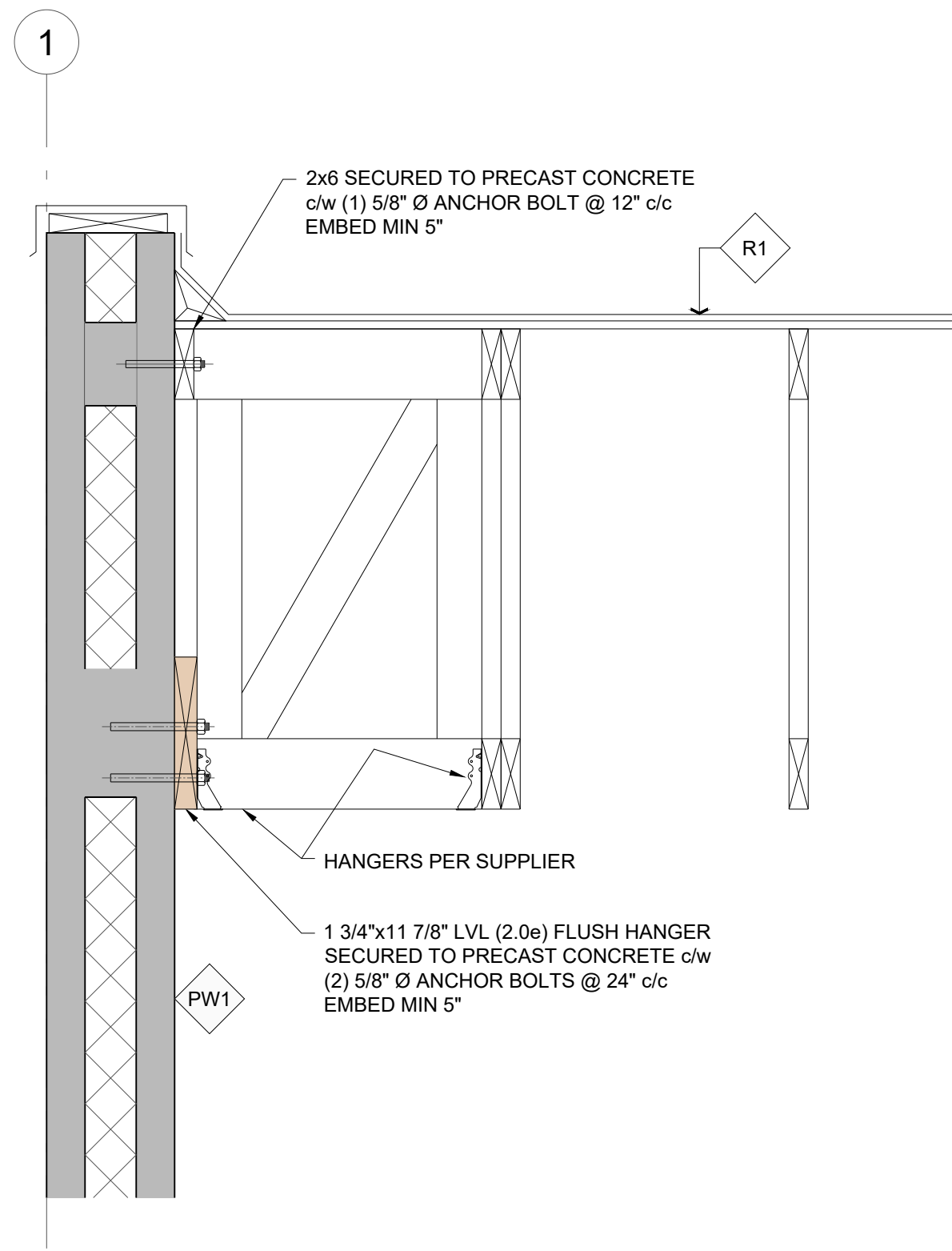

2 ROOF FRAMING DETAIL

S2.1 SCALE: 1"=1'-0"

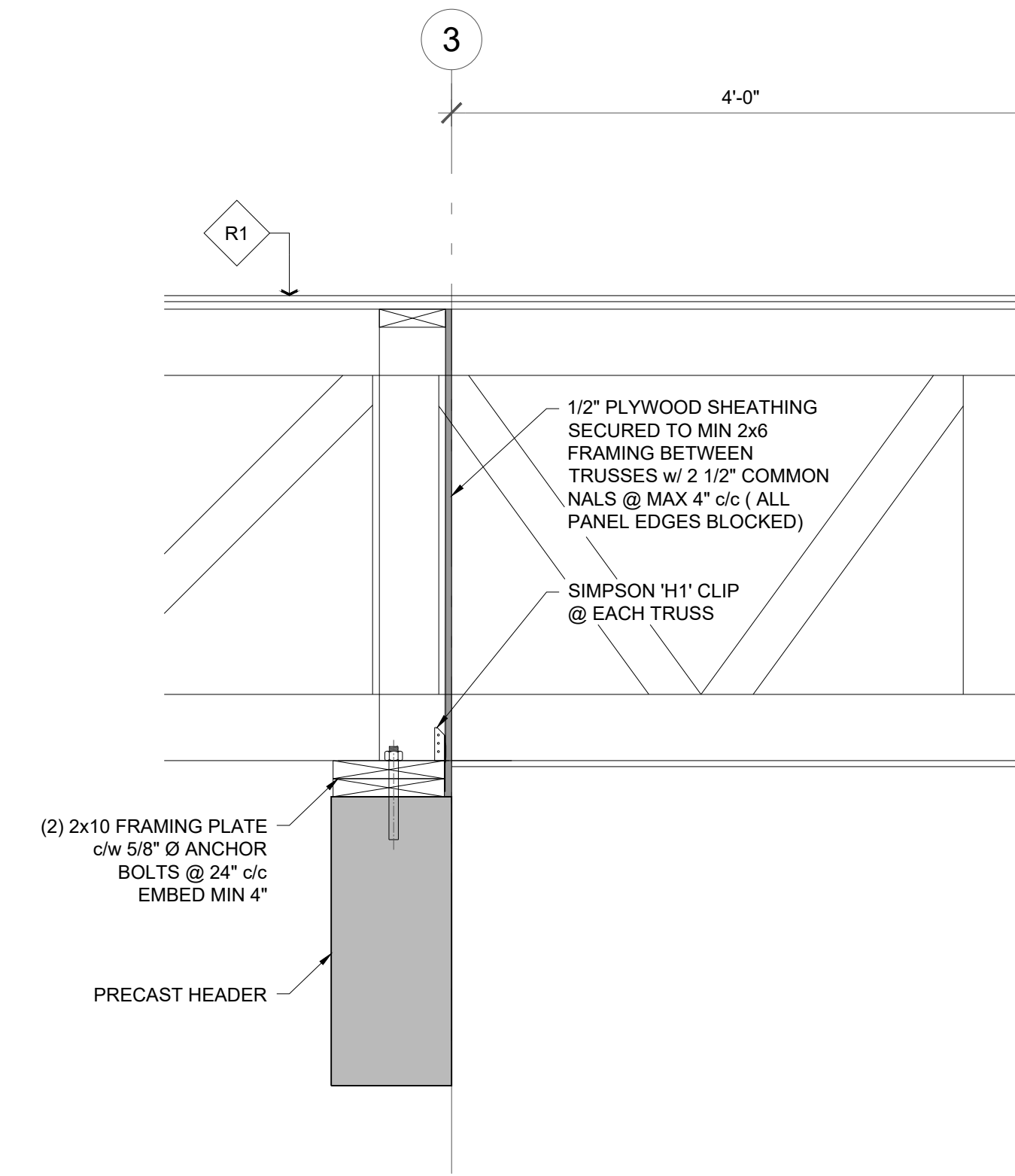

3 ROOF FRAMING DETAIL

S2.1 SCALE: 1"=1'-0"