



210-1715 Dickson Avenue Kelowna BC V1Y 9G6
250 762 9993 www.falcon.ca

FIRE HALL NO. 2 BUILDING ADDITION

SALMON ARM, BC

MECHANICAL SPECIFICATIONS

PROJECT NO: 24010.001

ISSUED FOR TENDER – JULY 10, 2024

PERMIT TO PRACTICE NO. 1001295

SPECIFICATIONS:

Section	Title	Pages
<u>DIVISION 20</u>		
20 00 05	Mechanical Schedules	1 – 5
20 00 10	General Mechanical Provisions	1 – 20
20 00 41	Equipment Start-Up	1 – 4
20 00 42	Testing	1 – 2
20 00 43	Test, Adjust, Balance	1 – 6
20 00 45	Documentation, Manuals and Record Drawings	1 – 3
20 00 60	Pipe and Pipe Fittings	1 – 4
20 00 90	Supports and Anchors	1 – 3
20 00 95	Sleeves, Flashing and Seals	1 – 2
20 10 00	Valves	1 – 3
20 20 15	Seismic Restraints	1 – 2
20 40 00	Plumbing – General	1 – 3
20 50 10	Fire Extinguishers	1 – 2
20 80 19	Gas Fired Unit Heaters	1 – 2
20 80 20	Fans	1 – 3
20 80 40	Ductwork	1 – 3
20 80 70	Air Outlets	1 – 2

SECTION 20 00 05 – MECHANICAL SCHEDULES

Salmon Arm FireHall #2 Addition					
Fan Schedule					
Ident		EF-100-2	CF-100-3	EF-100	EF-101
Status		New	New	Existing	Existing
Location		New Truck Bay	New Truck Bay	Existing Truck Bay	Hose Tower 101
Service		New Truck Bay	New Truck Bay	Existing Truck Bay	Hose Tower 101
Description		Vehicle Exhaust Fan	Ceiling Fan		
Manufacturer		Nederman	Canarm		Penn
Model		N27	CP60D11N		Z8H
Nominal Size		-	-		-
Air Flow	cfm	Variable	8945		340
External Air Pressure Drop	in wc	N/A	-		0.25
Width	in	24	-		
Length	in	24	-		
Height	in	18	16		
Diameter	in	-	60		
Weight	lbs	40	19		
Motor	HP	2	Fractional		30
Voltage/Phase		208-230/3/60	120/1		120/1
Accessories And Notes		<ul style="list-style-type: none"> ● Centrifugal Fan ● 240/1 Supply voltage ● VFD Model VFD-C for 5 hp motors: 230/3/60 ● 2x Generation 3 Radio Transmitter for vehicle ● Flange Adapter & Gasket ● Support Bracket c/w inlet adaptor, inlet & outlet guard net ● Generation 3 Radio Receiver for automatic start/stop ● Exhaust Fan C/W Magnail accessories: ● 2x MagnaRail 920 33' horizontal unit c/w busbar, brackets, trolley stop, end caps, and transformer ● 2x Shock absorber for trolley stop on exhaust rail ● 2x MagnaRail Extraction Unit, 6.25" dia x 10' ● 2x HB Nozzle for low level exhaust 	<ul style="list-style-type: none"> ● Interlock with existing ceiling fans 		<ul style="list-style-type: none"> ● Local Control
Electrical Coordination					

Salmon Arm FireHall #2 Addition							
Fan Schedule							
Ident		EF-103	EF-104	EF-105	EF-106	CF-100-1	CF-100-2
Status		Existing	Existing	Existing	Existing	Existing	Existing
Location		H.C./Women 103	Crew Room 104	Roof	Men 106	Existing Truck Bay	Existing Truck Bay
Service		H.C./Women 103	Crew Room 104	Kitchen 105	Men 106	Existing Truck Bay	Existing Truck Bay
Description						Ceiling Fan	Ceiling Fan
Manufacturer		Penn	Penn	Penn	Penn	-	-
Model		Z8H	Z8H	DX10S	Z8S		
Nominal Size		-	-	-	-		
Air Flow	cfm	160	340	255	225		
External Air Pressure Drop	in wc	0.25	0.25	0.25	0.25		
Width	in						
Length	in						
Height	in						
Diameter	in						
Weight	lbs						
Motor	HP	25	25	30	30		
Voltage/Phase		120/1	120/1	120/1	120/1		
Accessories And Notes		• Time Delay Off Switch	• Local Control	• Local Control	• Time Delay Off Switch		
Electrical Coordination							

Salmon Arm FireHall #2 Addition				
Unit Heater Schedule				
Ident		UH-100-3	UH-100-1	UH-100-2
Status		New	Existing	Existing
Location		Truck Bay	Existing Truck Bay	Existing Truck Bay
Service		Truck Bay	Existing Truck Bay	Existing Truck Bay
Description		Separated Combustion Unit Heater	Separated Combustion Unit Heater	Separated Combustion Unit Heater
Manufacturer		Reznor	Sterling	Sterling
Model		UDZ150	QVSF	QVSF
Nominal Size		150	150	150
Heating Input	btuh	150,000.0	150,000	150,000
Heating Capacity	btuh	124,250.0	120000	120000
Capacity Control		mod 2 stage 5:1	-	-
Air Flow	cfm	1,920	2225	2225
Width	in	39	-	-
Length	in	49	-	-
Height	in	20	-	-
Vent	in	5 Type B Double Wall	4	4
Combustion Air	in	6 Spiral Duct with Insulation	4	4
Gas Connection	in	1/2	-	-
Weight	lbs	180	260	260
Motor	HP	1/4	1/4	1/4
Voltage/Phase		120/1	120/1	120/1
Min. Mounting Height to u/s Unit	Ft	11	-	-
Accessories And Notes		<ul style="list-style-type: none"> ● Natural Gas ● Interlock with Existing ● Programmable Thermostat ● Ceiling Suspension Kit ● 34.4 to 3.5 kPa PRV ● Combustion Air Proving Switch ● High Limit Control ● Prewired Disconnect 	<ul style="list-style-type: none"> ● Natural Gas ● Separate Combustion ● Vertical Comb/Vent ● 120 V Room Temperature Sensor 	<ul style="list-style-type: none"> ● Natural Gas ● Separate Combustion ● Vertical Comb/Vent ● 120 V Room Temperature Sensor
Electrical Coordination		<ul style="list-style-type: none"> ● Connect to Disconnect 		

PLUMBING FIXTURES

For Commercial Applications

Job Name _____
 Job Location _____
 Engineer _____
 Approval _____
 Tag _____

Contractor _____
 Approval _____
 Contractor's P.O. No. _____
 Representative _____

CB-624/CB-2424

Dead Level® Trench Drain System

Catch Basins

Specification

Watts CB-624/CB-2424 Catch Basin for Dead Level® Pre-Sloped Trench Drain System, 6"(152) or 24"(610) (specify) wide x 24"(610) long x 24"(610) deep, with UV stabilized talc-filled polypropylene body with 4"(102) and 6"(152) no hub outlet connections, and polypropylene (6" wide only) or ductile iron frame. Catch Basin shall be frame-anchored with (specify) grating and lockdowns to suit DIN Class (specify) load rating. Installation to be performed in accordance with manufacturer's recommendations.

CB-2424

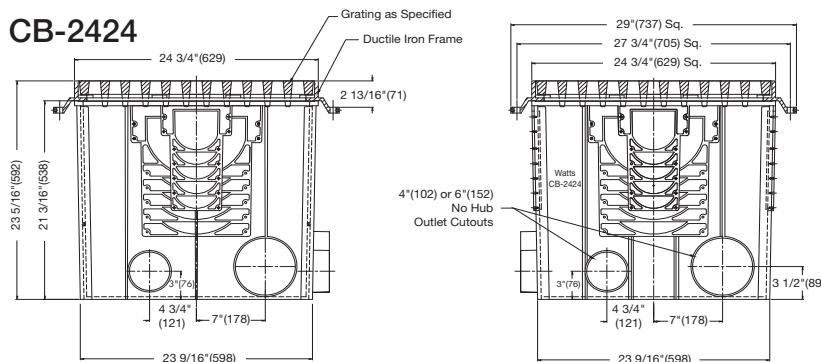

CB-624

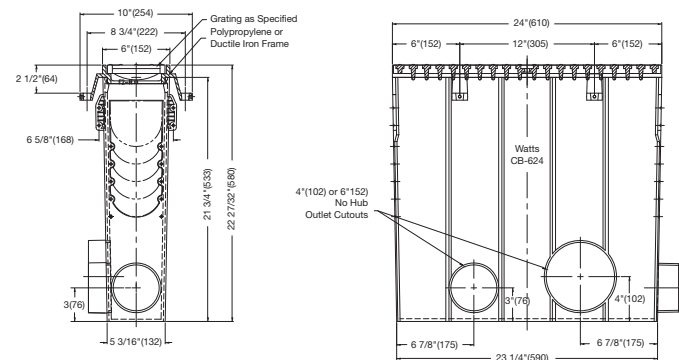

Please refer to watts.com for BAA information on specific models.

Watts product specifications in U.S. customary units and metric are approximate and are provided for reference only. For precise measurements, please contact Watts Technical Service. Watts reserves the right to change or modify product design, construction, specifications, or materials without prior notice and without incurring any obligation to make such changes and modifications on Watts products previously or subsequently sold.

Suffix	Grate Options Description	Load Class
CB-624P 6x24x24" w/Polypropylene Frame		
-BR	Decorative Bronze	Class B <input type="checkbox"/>
-DI	Ductile Iron	Class C <input type="checkbox"/>
-DI-ADA	Ductile Iron ADA	Class C <input type="checkbox"/>
-PP	Polypropylene	Class A <input type="checkbox"/>
-GP	Galvanized Perforated	Class A <input type="checkbox"/>
-GS	Galvanized Slotted	Class A <input type="checkbox"/>
-RGP	Reinforced Galvanized Perforated	Class C <input type="checkbox"/>
-RGS	Reinforced Galvanized Slotted	Class C <input type="checkbox"/>
-SP	Stainless Steel Perforated	Class A <input type="checkbox"/>
-SS	Stainless Steel Slotted	Class A <input type="checkbox"/>
-RSP	Reinforced Stainless Steel Perforated	Class C <input type="checkbox"/>
-RSS	Reinforced Stainless Steel Slotted	Class C <input type="checkbox"/>
-SCI	Solid Cast Iron	Class C <input type="checkbox"/>
CB-624D 6x24x24" w/Ductile Iron Frame		
-BR	Decorative Bronze	Class B <input type="checkbox"/>
-DI	Ductile Iron	Class F <input type="checkbox"/>
-DI-ADA	Ductile Iron ADA	Class F <input type="checkbox"/>
-PP	Polypropylene	Class A <input type="checkbox"/>
-GP	Galvanized Perforated	Class A <input type="checkbox"/>
-GS	Galvanized Slotted	Class A <input type="checkbox"/>
-RGP	Reinforced Galvanized Perforated	Class C <input type="checkbox"/>
-RGS	Reinforced Galvanized Slotted	Class D <input type="checkbox"/>
-SP	Stainless Steel Perforated	Class A <input type="checkbox"/>
-SS	Stainless Steel Slotted	Class A <input type="checkbox"/>
-RSP	Reinforced Stainless Steel Perforated	Class D <input type="checkbox"/>
-RSS	Reinforced Stainless Steel Slotted	Class E <input type="checkbox"/>
-SCI	Solid Cast Iron	Class F <input type="checkbox"/>
CB-2424 24x24x24" w/Ductile Iron Frame		
-None	Ductile Iron	Class F <input type="checkbox"/>
-RGS	Reinforced Galvanized Slotted	Class F <input type="checkbox"/>
-RSS	Reinforced Stainless Steel	Class F <input type="checkbox"/>

Suffix	Options Description
-T	Galvanized Trash Basket <input type="checkbox"/>
-TSS	Stainless Steel Trash Basket <input type="checkbox"/>

NOTICE

The information contained herein is not intended to replace the full product installation and safety information available or the experience of a trained product installer. You are required to thoroughly read all installation instructions and product safety information before beginning the installation of this product.



USA: T: (800) 338-2581 • F: (828) 248-3929 • Watts.com
 Canada: T: (888) 208-8927 • F: (888) 479-2887 • Watts.ca
 Latin America: T: (52) 55-4122-0138 • Watts.com

SECTION 20 00 10 – GENERAL MECHANICAL PROVISIONS

1. Description of Work

- .1 The scope of this contract includes but is not limited to the provision and installation of:
 - .1 Heating, ventilating and air conditioning equipment and accessories.
 - .2 Natural gas piping and accessories.
 - .3 Sanitary drainage piping and accessories, new and renovated.
 - .4 Storm drainage piping and accessories, new and renovated.
 - .5 Vent piping and accessories, new and renovated.
 - .6 Controls and accessories.
 - .7 Renovation or removal of existing systems, services and equipment.
 - .8 Renovations, cutting and patching.
 - .9 Cutting and patching for wall and floor openings less than 150 mm in any dimension.
 - .10 Floor protection and cleanup.

2. Accessibility and Location of Equipment & Fixtures

- .1 Location of equipment, fixtures and outlets indicated or specified are to be considered as approximate.
- .2 Locate equipment, fixtures and distribution systems to provide minimum interference and maximum usable space and in accordance with manufacturer's recommendations for safety, access and maintenance.
- .3 Install all work so as to be readily accessible for adjustment, operation and maintenance. Furnish access panels where required in building surfaces for installation by building trades.
- .4 Locate access panels in service areas wherever possible. Do not locate in panelled or special finish walls, without prior approval.
- .5 If any doubt exists, inform Consultant of impending installation and obtain his approval for actual location.

3. Alternative Products or Systems

- .1 Where a list of acceptable materials, equipment or suppliers is included in this Division of the specification, Tenders are to be based on use of the specified equipment or equipment included in the acceptable materials clauses.
- .2 Where no list of acceptable materials, equipment or suppliers is included in the specification sections, Tenders are to be based on use of the specified materials, equipment or suppliers or any other material that complies with the specifications for quality, certification, material, performance, etc. A request for approval to supply alternative materials, equipment or suppliers is not required.
- .3 Request to have alternative materials, equipment or suppliers added to the list of acceptable materials, equipment or suppliers will be considered. Submit proposals to supply alternative materials, equipment or suppliers of equipment in writing, to the Engineer at least seven days, unless otherwise noted, prior to Tender Closing Date for Division 20.
- .4 Materials or equipment alternatives: Identify specific materials or equipment for which alternates are requested. Provide specific technical data indicating dimensions, performance, weight, size, arrangement, etc. and other data as necessary or requested.
- .5 Suppliers or contractor alternatives: Provide references, project history, technicians qualifications, etc. and other data as necessary or requested.

- .6 Where specified equipment is included in a schedule, the request for approval must include an identical schedule, with each value of the alternate equipment compared to the specified equipment value. Photocopied schedules, marked with the alternate characteristics, would be acceptable.
- .7 All costs, including fees for re-design and record document correction, required to adapt alternative materials, equipment or suppliers shall be the responsibility of the Contractor.
- .8 Addition of materials, equipment or suppliers to the specifications will be by written addendum only.

4. Cash Allowances

- .1 Payments are to be made to appropriate suppliers or agencies for services and materials provided with respect to the Cash Allowance subjects.
- .2 Contractors' costs for overhead, markup, administration or other costs are to be included in the Base Price, not in the Cash Allowance values.
- .3 Guidelines for detailing costs for time and material allowances, as outlined in section 6.3.6 and 6.3.7 of the CCDC 2, 2020
- .4 Include Cash Allowances as identified for the following:
 - .1 The following schedule lists the Cash Allowances to be included in the Stipulated Price:

Ident.	Description	Base Values	GST (5%)	Total
CA-1	Record Drawings Div. 20	\$1,200.00	\$60.00	\$1,260.00
CA-2	Nederman Vehicle Exhaust and Magnarail (EF-100-2) Div. 20	\$45,000.00	\$2,250.00	\$47,250.00

5. Certificates & Transcripts

- .1 Submittals prior to start of construction:
 - .1 Certified copy of Insurance required to be provided by the Contractor.
 - .2 Letter of compliance with WorkSafeBC.
 - .3 Building permit compliance.
 - .4 Construction Schedule.
 - .5 First Aid Attendant name and certification level
 - .6 Name of qualified safety coordinator
 - .7 List of first aid equipment and supplies complying with hazard classification, number of employees and emergency transport time.
 - .8 Submittals as required elsewhere in this specification.
- .2 Submittals prior to initial progress claims:
 - .1 Cost breakdown.
 - .2 Submittals as required elsewhere in this specification.
- .3 Submittals during construction:
 - .1 Contractor's Statutory Declaration, on forms approved by C.C.A. is to accompany all progress claims subsequent to initial claim. Declaration is to certify that all past claims have been paid as certified or as noted and must be properly signed and notarized.
 - .2 Submittals as required elsewhere in this specification.
- .4 Submittals prior to Substantial Performance:
 - .1 Occupancy Permit and Inspection Certificates from authorities having jurisdiction and as required for equipment items to comply with governing Codes and Regulations.
 - .2 Operation and maintenance manuals.
 - .3 Record drawings.

- .4 Results of all Tests required by the specification.
- .5 Refer to Substantial Performance in this Section.
- .6 Submittals as required elsewhere in this specification.
- .5 Submittals at Total Performance:
 - .1 Refer to Project Close-out in this Section.
 - .2 Submittals as required elsewhere in this specification.

6. Changes and Clarifications to the Contract

- .1 During tender period: Errors, omissions or any questions regarding this Project must be referred to the Consultant for clarification or correction not later than five working days prior to the Tender Closing Date. Any corrections or changes necessary to the Tender Documents will be contained in an Addendum issued by the Consultant. All such corrections or changes confirmed by Addendum shall become part of the Tender Documents and their effect shall be included in the Tenderer's Contract Price. No extras will be permitted for elements of the Project which may be reasonably inferred from the Tender Documents to complete the Project. No proposed changes to the Contract, verbal or otherwise, shall be considered valid unless they are also included in a written addendum.
- .2 After tenders have been submitted, but prior to award of contract: Any corrections or changes necessary to the Tender Documents will be contained in a Post Tender Addendum issued by the Consultant. Submit the cost for each change itemized in the Post Tender Addendum. Changes will not be considered part of the Contract unless confirmed in the letter of intent.
- .3 During the course of construction, after award of the Contract: Any corrections, changes or clarifications necessary to the Contract Documents will be contained in either a Change Notice, a Change Order, a Change Directive, or a Site Instruction issued by the Consultant. No proposed changes to the contract, verbal or otherwise, shall be considered valid unless they are also included in a written Change Directive or Change Order.
 - .1 Change Notice: All Change Notice items are contemplated changes. Work is not to proceed until authorized by a Change Order. All materials and workmanship are to be as described in the contract documents unless otherwise stated. Provide a price for each item, including materials and labour breakdown. Provide further breakdowns as directed by the Consultant. Indicate any change to the time of completion that will result from acceptance of the Change Notice items.
 - .2 Change Order: Change Order items refer to Change Notice items that have been accepted and become part of the contract. The work is to proceed at the agreed upon price, which will be attached to the Change Order.
 - .3 Change Directive: All Change Directive items become part of the contract. The work described shall proceed on a time and materials basis. Time and material costs must be submitted to the Consultant for review. Guidelines for detailing costs as outlined in section 6.3.6 and 6.3.7 of the CCDC 2, 2020.
 - .4 Site Instruction: All Site Instruction items are to be considered as clarifications to the contract, and not as additional work. No change to the Contract Price or time of completion will be accepted.

7. Codes and Standards

- .1 The work, including all materials, labour and other services shall conform, but not be limited to the requirements of the latest editions of the following Codes, Bylaws, Standards and Regulations:
 - .1 British Columbia Building Code.
 - .2 Local Building Bylaws.
 - .3 WorkSafeBC.

- .4 Canadian Standards Association.
- .5 British Columbia Plumbing Code.
- .6 Canadian Electrical Code.
- .7 CSA B149.1 Natural Gas and Propane Installation Code.

8. Construction Schedule

- .1 Immediately following award of contract, the contractor will meet with the Consultant and the Owner to establish parameters of scheduling preparatory to preparing firm Construction Schedules.
- .2 Construction Schedule: Within 20 working days of Award of Contract, submit to the consultant, a detailed Construction Schedule.
- .3 The Construction Schedule shall clearly show a complete and detailed sequence of operations for all trades and an orderly performance and completion of the various parts of the work to attain the completion date.
- .4 The Construction Schedule shall indicate submission and approval dates for shop drawings and dates for preparing and submitting project close out documentation.
- .5 The approved Construction Schedule shall be monitored on a monthly basis to indicate construction progress. Should the Contractor fall behind the schedule indicated by the Construction Schedule such as to jeopardize any of the completion dates, the contractor shall rework the construction schedule to show a reorganization of the remaining work to bring the work back on schedule and to achieve the specified completion dates.
- .6 If the Construction Schedule is revised, resubmit the revised Construction Schedule for approval and reissue.

9. Contract Breakdown

- .1 After tenders close, submit a breakdown of contract price into divisions to the satisfaction of the Engineer with aggregate of breakdown totalling total contract amount. Breakdown will be used in computing of progress claims. Progress claims, when submitted, are to be itemized against each item of the contract breakdown.

10. Contractor's Use of Site

- .1 Do not unreasonably encumber site with materials and equipment. Confine all operations within the area of the building and to other areas only as directed.
- .2 Move stored products, trailers and equipment which interfere with operations of Other Contractors or to comply with the Owners requirements.
- .3 The Contractor's use of the site will be restricted to the specific areas to be assigned at the commencement of the on-site construction, except for approved access.
- .4 The Contractor shall not close or obstruct streets, sidewalks, lanes or other public rights of way without having first obtained required permits from the authorities having jurisdiction.
- .5 The Contractor shall maintain adequate traffic control procedures during his operations, including delivery and off-loading of materials, on or adjacent to streets, sidewalks, lanes, public rights of way, and parking areas available for use by the public.
- .6 During progress of the Work, the Contractor shall maintain an emergency response plan that includes adequate means of egress from the Project in the event of fire or other emergency and shall not cause materials to be stored in a manner that will impair such means of egress.
- .7 The Contractor shall not diminish, by his operations, adequate means of access to and egress from the existing premises of the Owner and shall undertake at his own expense, measures to ensure such means of access and egress as the Engineer may reasonably direct including construction of temporary means as required.

- .8 All personnel, including the Prime Contractor's employees, subcontractors' employees, suppliers, testing agencies, and any other personnel under the supervision of the Prime Contractor, must sign the Owner's sign-in sheet at the main office if on site during the Owner's normal operating hours.
- .9 Owner's normal operating hours are defined as, Monday to Friday, 6:30 a.m. to 6:00 p.m.

11. Cutting and Patching – New Work

- .1 Locate holes and provide sleeves, required for mechanical work. Relocate improperly located holes and sleeves.
- .2 Drill for expansion bolts, hanger rods, brackets and supports.
- .3 Structural members of building shall not be removed, modified, cut or burned without obtaining prior written approval from the Engineer.
- .4 Provide openings and holes required in cast members for mechanical work. Cast holes larger than 100 mm. Holes smaller than 100 mm may be cut or cored.
- .5 Cutting and patching is specified under the sections of specifications covering these materials.

12. Cutting and Patching - Renovation

- .1 Execute cutting, fitting and patching required to make Work fit properly together.
- .2 Making good is defined as matching the adjacent surfaces such that there be no visible difference between existing and new surfaces when viewed from 1.5 m in the ambient light and includes painting the whole surface to the next change of plane.
- .3 Obtain Consultant's approval before cutting, boring or sleeving load-bearing members.
- .4 Make cuts with clean, true, smooth edges. Make patches inconspicuous in final assembly.
- .5 Fit work airtight to pipes, sleeves, ducts and conduits.
- .6 At penetrations of fire rated assemblies, with any services or ducts completely seal voids with approved fire resistive material, for the full thickness of the construction element and to comply with Code requirements.
- .7 The Contractor shall do all minor cutting and drilling that may be required to make several parts of the Work come together properly. Minor cutting includes but is not limited to:
 - .1 Hole drilling in wood or concrete for pipes and conduits up to 150 mm diameter.

13. Demolition of Existing Systems and Equipment

- .1 Remove all identified equipment and systems complete with controls, mounting devices, electrical connections, control connections, mechanical services, gas connection, domestic water connection, etc.
- .2 Dispose of all general construction waste and debris, including removed equipment, piping, conduit, insulation, accessories, etc. off site in a manner that complies with all applicable regulations.
- .3 Cut and cap services at the nearest main. Do not leave dead legs.
- .4 Where existing service is insulated, provide equivalent insulation at the capped location. Ensure that new and existing insulation is continuous and that the vapour barrier is intact.
- .5 Do not abandon equipment or systems in place unless otherwise indicated.
- .6 Patch and make good any building elements damaged by demolition work. This includes mounting points.

14. Demonstration Instruction to Owner

- .1 Prior to demonstrating the system, ensure that all fan belts are tightened.

- .2 Demonstrate to and instruct representatives designated by the Owner on the complete systems operating and maintenance procedures using the assistance of specialist sub trades and manufacturers' representatives.
- .3 Participate in, and aid the Commissioning Agent in, the Commissioning and Demonstration process for each system. Demonstration and training sessions will be convened separately for each piece of equipment and each individual system.
- .4 Obtain a signed statement from the Owner certifying that the demonstration and instruction have been given to his satisfaction.
- .5 Obtain a list of all persons attending commissioning, demonstration, or training sessions, including their signatures and job title.

15. Drawings and Measurements

- .1 Drawings are generally diagrammatic and intended to indicate the scope and general arrangement of work. Do not scale the drawings. Take field measurements where equipment and material dimensions are dependent upon building dimensions.
- .2 Review all drawings and documents for all trades on the project. Coordinate work specified in this Division with that of other Divisions. Advise other trades of requirements specified in this Division, and how those requirements affect the other trades.
- .3 Consult the Architectural, Structural, Electrical, and all other drawings and details for exact locations of fixtures and equipment, mechanical and otherwise. Obtain this information from the Engineer where definite locations are not detailed.

16. Engineer Approval

- .1 It is not incumbent upon the Engineer to superintend the work so as to relieve the Contractor of any responsibility.
- .2 Permission to proceed does not constitute approval of the work, or portion thereof.
- .3 Approval of the work shall be made only upon the successful conclusion of tests and satisfactory performance under design operating conditions.

17. Environmental Protection

- .1 Fires and burning of rubbish on site not permitted.
- .2 Do not bury rubbish and waste materials on site.
- .3 Do not dispose of waste or volatile materials such as oil, paint thinner or mineral spirits into waterways, storm or sanitary sewers on site or elsewhere.
- .4 Provide temporary drainage and pumping as necessary to keep excavations and site free from water.
- .5 Control disposal of run-off of water containing suspended materials or other harmful substances in accordance with local authority requirements.
- .6 Protect trees and plants on site as designated by the Consultant.
- .7 Cover or wet down dry materials and rubbish to prevent blowing dust and debris.

18. Equipment Inventory

- .1 The Engineer will provide an inventory and submittal schedule to the Contractor at the commencement of the project. Fill out sheets and submit together with shop drawings.
- .2 The Engineer will issue revised sheets from time to time during the project. Complete these sheets as required and resubmit.

19. Equipment Protection Cleanup

- .1 Protect equipment and materials in storage and on site, during and after installation until final acceptance. Leave factory covers in place and take special precautions to prevent entry of foreign material into working parts of piping and duct systems.
- .2 Protect equipment with polyethylene covers and crates.
- .3 Thoroughly clean piping, ducts and equipment of dirt, cuttings and other foreign substances.
- .4 Protect bearings and shafts during installation. Grease shafts and sheaves to prevent corrosion.
- .5 Cover and protect all floors, furniture, millwork, computers, servers and other information technology equipment. Coordinate with the owner to remove any equipment that is at risk and cannot be protected.

20. Gas Inspection

- .1 Submit to the Provincial Gas Inspection Department, drawings, applicable sections of specifications and detailed drawings as required to obtain approval for the gas installation.

21. Identification and Labelling

- .1 Equipment and panels: Provide 4 labels per unit and affixed to the unit such that they can be seen from any direction. Labels to be affixed to the unit 1 inch below the top rim of the unit and in the middle of a horizontal side, or wherever maximum visibility can best be achieved. Provide Brother P-Touch 24 mm strong self-adhesive labels, model TZ-S251, with Arial font, minimum 70 pt. font size for the following items:
 - .1 Control panels.
 - .2 All equipment provided under this Division.
 - .3 Refer to Section 20 90 00, Controls.
- .2 Pipes: Label with 25 mm high black letters on a white background on the following items, after painting is complete. Use stencil or pressure sensitive tape labels.
 - .1 All pieces of equipment supplied under this Division.
 - .2 Pipe runs. Identify system as well as flow direction. Identify at 15 metre intervals or less, as required.
 - .3 Gas piping: not more than 6.0 metre intervals, at change of direction, where passing through walls and ceilings, or entering or leaving other concealed space.
 - .4 Non-Potable Water piping: not more than 6.0 metre intervals, at change of direction, where passing through walls and ceilings, or entering or leaving other concealed space.
 - .5 Radon Vent piping: not more than 3.0 metre intervals, at change of direction, where passing through walls and ceilings, or entering or leaving other concealed space.
 - .6 Piping system label abbreviations must match the abbreviations used on the mechanical drawings and schematics. Refer to Mechanical legend.
- .3 Temporary equipment labels: Until permanent equipment labels have been installed, provide temporary labeling for use during course of construction to aid site coordination. Provide enough labels that the equipment can be identified on all sides that it may be viewed. Temporary labeling shall be completed once equipment has been uncrated and prior installation. Temporary labels shall be either removed or hidden once permanent labels are installed.
- .4 Valves: Provide numbered stamped brass or engraved plastic tags secured to all valves other than equipment isolation valves and produce valve schedule for Maintenance Manuals.

22. Intent

- .1 Provide complete and fully operational mechanical systems with facilities and services to meet requirements described herein and in complete accord with applicable codes and ordinances.
- .2 The building and systems must be handed over to the owner in a complete, operational, and as-new condition. Repair or replace any finishes, or other components that have been damaged during the course of construction.
- .3 Follow manufacturer's recommended installation details and procedure for equipment supplemented by the contract documents.
- .4 Install equipment in locations and routes shown, close to building structure with minimum interference with other services or free space. Remove and replace improperly installed equipment.
- .5 Provide labour and materials required to install, test and place into operation on the mechanical systems. Provide additional material for modifications required to correct job conflicts.
- .6 The word "provide" shall mean "supply and install" unless otherwise indicated.
- .7 In the event of a disagreement between the drawings and specifications, the specifications shall take precedence.
- .8 Any reference to the Consultant or the Engineer in this Division shall mean Falcon Engineering.
- .9 The main divisions of the work of this Division generally includes the supply and installation and proper start-up of the following:
 - .1 Heating, Ventilating, Air Conditioning Systems.
 - .2 Exhaust and Ventilation Systems.
 - .3 Plumbing Systems.
 - .4 Equipment Control Systems.
 - .5 Modifications to Existing Systems.

23. Location of Equipment & Fixtures

- .1 Location of equipment, fixtures and outlets indicated or specified are to be considered as approximate.
- .2 Locate equipment, fixtures and distribution systems to provide minimum interference and maximum usable space and in accordance with manufacturer's recommendations for safety, access and maintenance.
- .3 Install all work so as to be readily accessible for adjustment, operation and maintenance. Furnish access panels where required in building surfaces for installation by building trades.
- .4 Locate access panels in service areas wherever possible. Do not locate in panelled or special finish walls, without prior approval.
- .5 If any doubt exists, inform Consultant of impending installation and obtain his approval for actual location.

24. Materials and Equipment

- .1 Material and Equipment:
 - .1 Use new material and equipment unless otherwise specified.
 - .2 Provide material and equipment of specified design and quality, performing to published ratings and for which replacement parts are readily available.

- .3 Use products of one manufacturer for equipment or material of same type or classification unless otherwise specified.
- .4 All Equipment and materials shall conform to the requirements of ASHRAE 90.1.
- .2 Manufacturer's Instructions:
 - .1 Unless otherwise specified, comply with manufacturer's latest printed instructions for materials and installation methods. Obtain manufacturer's IOM and use start-up instructions for correct start-up of equipment.
 - .2 Notify Consultant in writing of any conflict between these specifications and manufacturer's instructions. Consultant will designate which document is to be followed.
- .3 Fastenings, General:
 - .1 Provide metal fastenings and accessories in same texture, colour and finish as base metal in which they occur. Prevent electrolytic action between dissimilar metals. Use non-corrosive fasteners, anchors and spacers for securing exterior Work.
 - .2 Space anchors within limits of load bearing or shear capacity and ensure that they provide positive permanent anchorage. Wood plugs not acceptable.
 - .3 Keep exposed fastenings to minimum, space evenly and lay out neatly.
 - .4 Fastenings which cause spalling or cracking of material to which anchorage is made are not acceptable.
 - .5 Explosive actuated fastening devices shall comply with CSA Z166.
- .4 Fastenings, Equipment:
 - .1 Use fastenings of standard commercial sizes and patterns with material and finish suitable for service.
 - .2 Use heavy hexagon heads, semi-finished unless otherwise specified. Use No. 304 stainless steel for exterior areas.
 - .3 Bolts may not project more than one diameter beyond nuts.
 - .4 Use plain type washers on equipment, sheet metal and soft gasket lock type washers where vibrations occur and resilient washers with stainless steel.
- .5 Delivery and Storage:
 - .1 Deliver, store and maintain packaged material and equipment with manufacturer's seals and labels intact.
 - .2 Prevent damage, adulteration and soiling of material and equipment during delivery, handling and storage. Immediately remove rejected material and equipment from site.
 - .3 Store material and equipment in accordance with supplier's instructions.
 - .4 Touch-up damaged factory finished surfaces to Consultant's satisfaction. Use primer or enamel to match original. Do not paint over name plates.

25. Miscellaneous Metal

- .1 Be responsible for all miscellaneous steel work relative to Division 20 of the Specifications, including but not limited to:
 - .1 Support of equipment.
 - .2 Hanging, support, anchoring, guiding and relative work as it applies to piping, fans and mechanical equipment.
 - .3 Pipe anchor and/or support posts.
 - .4 Ceiling ring bolts - secure to structure or steel supports.

26. Owner Occupancy

- .1 The Owner will occupy the premises during the entire period of construction for the conduct of his normal operations. It is mandatory to cooperate with the Owner's Representative in all construction operations to minimize conflict, and to facilitate the Owner's continued and uninterrupted usage.
- .2 Schedule work so as not to disturb, disrupt, or endanger building occupants or normal facility operations. Coordinate work with the Owner's designated representative.
- .3 Provide 48 hours' notice to the Owner's Designated Representative prior to disruption of systems. Obtain approval prior to proceeding with systems shutdown or disruption.
- .4 Provide temporary work as required to maintain systems in operation at all times. Short periods of discontinuous service may be approved for reconnection, modification or renovation of services or systems.
- .5 The Owner may instruct the contractor to activate systems in the area of work even if the remainder of the construction and installation of building components is not complete. The Contractor must schedule his work to allow minimal periods of inoperable system operation in the area of work.
- .6 During periods of normal operating, work in occupied sections of the building will not be permitted. Work will be allowed to proceed in the only during periods. The Owner will allow access to the building after normal occupied hours and on weekends, subject to approval and coordination with the Owner's designated representative.

27. Permits and Fees

- .1 Give all necessary notices, obtain all necessary permits, and pay all fees in order that the work may be carried out.
- .2 Furnish any certificates necessary and evidence that the work installed conforms with regulations of all authorities having jurisdiction before final certificates are issued.

28. Prior Tests and Reviews

- .1 Test all work prior to concealment.
- .2 Notify the Engineer of the requirements for reviews or tests with forty-eight hours' notice.
- .3 If instructed by the Engineer, material installed under this Division and covered before approval, must be exposed or uncovered at contractor's cost for the necessary review.

29. Project Coordination

- .1 Coordinate progress of the Work, progress schedules, submittals, use of site, temporary utilities and construction facilities.
- .2 All Contractors are required to perform an on-site examination prior to commencing Work and notify the Consultant of any deviation from the Contract Documents. Commencement of Work shall indicate acceptance of existing conditions.
- .3 The responsibility as to which sub-trade supplies and installs any and all materials rests solely with the Prime Contractor.
- .4 Extras to the Contract will not be considered based on grounds of difference in interpretation of plans and specifications as to which trade involved shall be responsible for certain materials, installation or specialties.
- .5 The Contractor shall do all cutting and remedial Work that may be required to make several parts of the Work come together properly. Coordinate the schedule to ensure that as much as possible is built into the Work and that this requirement is kept to a minimum.

30. Protective Coatings and Painting

- .1 All exposed steel piping, hangers, supports, brackets, stands and other miscellaneous metal and uncoated steel surfaces which is supplied under this Division are to be prime coated. Ceiling spaces, pipe shafts, and crawl spaces are not considered exposed.
- .2 Finish painting of all equipment and material installed under this Division is specified under Division 9 of the specification, unless specified otherwise.
- .3 Apply one coat of galvanizing paint to all steel which has had its galvanized coating damaged or sheared.

31. Ready for Takeover Procedures

- .1 Refer to GC.1 Ready for Takeover.
- .2 The contractor shall make application for Ready for Takeover in writing to the engineer.
- .3 Prior to the Ready for Takeover Review, provide a comprehensive list of items to be corrected or completed.
- .4 Prerequisites to attain of Ready for Takeover of the Work are limited to the following:
 - .1 Ready for Substantial Performance. Ready for Takeover and Substantial Performance can be declared on the same date by the certifier.
 - .2 The area of upgrade is occupiable.
 - .3 Submission of appropriate letters of Assurance of Professional Field Review and Compliance including but not limited to:
 - .1 Seismic Restraints
 - .4 Final Cleaning and waste removals.
 - .5 Operating and Maintenance Manuals have been approved by the engineer and finalized copies are the possession of the Owner.
 - .6 Record Drawing mark ups have been reviewed by the engineer and a copy in the possession of the Owner. Drafted Record drawings may be submitted later.
 - .7 Start Up and functional testing for all equipment supplied under the contract is completed and documentation is submitted in the Operating and Maintenance Manuals.
 - .8 Warranty Letters or Forms for required systems and materials are completed and submitted in the Operating and Maintenance Manuals.
 - .9 Control systems are fully operational. For systems that utilize a Building Automation System (BAS), ensure the following:
 - .1 As-Built control shop drawings are included in the Operating and Maintenance Manuals.
 - .2 Control Systems Trend Logs showing each controls device is operating properly at the time of Takeover, are printed in color and turned over to engineer.
 - .10 The Balancing and Commissioning are completed, and reports are submitted in The Operating and Maintenance Manuals.
 - .11 Demonstration and Training of Owner's identified representative(s) is complete and a signed record of attendance is in the Operating and Maintenance Manuals.
 - .12 Receipt signed by owner for required spare equipment and materials is submitted in the Operating and Maintenance Manuals.
 - .13 Provide all prerequisite documentation to the engineer prior to making application for Ready for Takeover.

- .5 During the Ready for Takeover Review, a list of deficiencies and defects will be tabulated. A value for deficiency holdback will be evaluated and established by the consultant, based on this deficiency list. The value of the deficiency holdback shall be twice the aggregate value of the work to be completed.
- .6 Should the Consultant be required to repeat a Ready for Takeover Review due to failure of the Work to comply with the claims of Ready for Takeover made by the Contractor:
 - .1 Owner will compensate the Consultant for such additional services.
 - .2 Owner will deduct the amount of such compensation from the final payment to the Contractor.

32. Record Drawings

- .1 Keep on site, an extra set of drawings and specifications recording changes and deviations daily.
- .2 Include all details from revision drawings, supplementary drawings, change order and addenda.
- .3 Record drawings shall precisely identify the configuration, size and location of all systems and equipment installed under this Contract.
- .4 Before Substantial Performance submit for approval to the Engineer, completed and detailed marked up white prints to reflect the record drawing status.
- .5 Contractors must allow time to review marked up drawings with the Engineer at the Engineer's office and provide clarification where required.
- .6 Contractors shall certify final reproducible record drawings to be correct by notation and signature.
- .7 A Cash Allowance has been specified to cover the Consultant's cost of the following:
 - .1 Updating the original computer software to include all changes recorded on the record white prints.
 - .2 Plotting one set of full-size reproducible record drawings.
 - .3 Plotting one set of reduced size reproducible record drawings.
 - .4 Photocopying three sets of reduced sized record drawings.
- .8 After the contractor certifies and signs the completed record drawings, the contractor shall provide with each Maintenance Manual, the following record materials provided under the Cash Allowance.
 - .1 One set of full-size record drawings attached with each Manual.
 - .2 One set of reduced size record drawings bound in each Manual.
- .9 After the contractor certifies and signs the completed record drawings, the contractor shall submit or distribute the following record materials provided under the Cash Allowance.
 - .1 One set of full-size reproducible record drawings to the Engineer.

33. Related Work

- .1 General Requirements – Refer to Architectural.
- .2 Division 20 Specifications form part of the Contract Documents and shall be read, interpreted and coordinated with all other Divisions. The Instruction to Tenderers, General Instructions, General Conditions, Supplementary General Conditions and Amendments and Supplements thereto, form a part of this Division and contain items related to the mechanical work.

34. Responsibility

- .1 Check drawings of all trades to verify space and headroom limitations for work to be installed. Coordinate work with all trades and make changes to facilitate a satisfactory installation. Make no deviations to the design intent involving extra cost to the Owner without written approval.
- .2 Promptly advise the Engineer of any specified equipment, material, or installation of same which appears inadequate or unsuitable, in violation of laws, ordinances, rules or regulations of authorities having jurisdiction; of any necessary items of work omitted from the Contract Documents; or of any discrepancies in the Specifications.
- .3 When the Contract Documents do not contain sufficient information for proper selection or bidding, notify the Engineer during the tendering period. Failure to do this shall not relieve the Contractor of responsibility to supply the intended equipment.
- .4 The Contractor is to consider that this is a renovation project. Reasonable allowances must be included for refitting or relocation of services and components that may be discovered during the course of construction that were not apparent at the commencement of the project, shown on plans, or concealed in walls, ceilings or floors. Necessary accessories for connection and modifications of configurations or materials shall be included at no extra cost to the Owner.
- .5 Provide all necessary coordination, materials and labour so that all existing services, systems and equipment shall remain in service the period necessary. Determine requirements by review of documents and site conditions.

35. Setting Out of Work

- .1 Assume full responsibility for and execute complete layout of Work to locations, lines and elevations indicated. Provide devices needed to lay out and construct Work.
- .2 Exercise proper precautions to verify figures shown on the drawings, before laying out of work, and be responsible for any errors resulting from failure to exercise such precautions.
- .3 The drawings indicate the general location and route to be followed by the pipes and ducts, etc. Install so as to conserve headroom and interfere as little as possible with the free use of the space through which they pass. Keep all ducts, pipes, etc. at the ceilings as tight as possible to beams or other limiting members. Where headroom or space conditions appear inadequate, notify the Consultant before proceeding with fabrication and/or installation.
- .4 Ensure non-interference between heating, plumbing, drainage, electrical and other equipment.
- .5 Make any corrections required in order to avoid the work of other trades, and/or as required by the Owner.
- .6 Maintain integrity of fire separations and compartments.

36. Shop Drawings, Product Data and Samples

- .1 Shop drawings must be submitted and reviewed by the Consultant prior to the contractor ordering or shipping any subject equipment. Payments will not be processed for equipment not properly documented and reviewed under the terms of submittal.
- .2 Shop drawings shall be submitted in Imperial Units. Shop drawings not submitted in the correct units will be automatically returned without review.
- .3 Group shop drawings by specification section for inclusion in Maintenance Manual. Do not combine items from separate specification sections into a single submission without separate cover pages for each specification section.

-
- .4 Submit materials and equipment by manufacturer, trade name and model number. Include copies of applicable brochure or catalogue material. Do not assume applicable catalogues are available in the Engineer's office. Maintenance and operating manuals must be included but are not suitable submittal material on their own.
 - .5 Include Maintenance and Operating Manuals (IOM). Specifically ensure that the IOM documents include manufacturer's instructions for correct start-up of the equipment.
 - .6 Review of the shop drawings by the Engineer does not relieve the contractor or his supplier of the responsibility to provide the correct and complete equipment, material or installation.
 - .7 Prior to submission to the Engineer, the Contractor shall review all shop drawings. By this review the Contractor represents that he has determined and verified all field measurements, field construction criteria, materials, catalogue numbers and similar data or will do so and that he has checked and coordinated each shop drawing with the requirements of the Work and of the Contract Documents.
 - .8 The Contractor's review of each shop drawing shall be indicated by his approval stamp, date and signature on the front of each page. Drawings will not be considered if not previously checked by the Contractor.
 - .9 Clearly mark each sheet of printed submittal material, using arrows, underlining or circling, to show particular sizes, dimensions, wiring diagrams, operating clearances, control diagrams, project identification, types, model numbers, ratings, capacities and options actually being proposed. Cross out non-applicable material. Note on the submittal specified features such as special tank linings, pump seals, materials or painting.
 - .10 The contractor shall identify in writing, on the shop drawings, all aspects, accessories, options etc. that do not conform to the tender documents. Failure to do so will result in work being rejected.
 - .11 The mechanical contractor and the general contractor shall each review the shop drawings then stamp and initial the front page of each submission package and sign the original transmittal form. The contractor's shop drawing review shall include a detailed review of all installation details to ensure that they do not conflict with other trades, and to ensure that the system can be installed as intended.
 - .12 Submit ONE reproducible copy or PDF version of each shop drawing and all supporting material, sufficiently in advance of requirements to allow time for review. Reproducible means photocopy capable for small sheets up to 280 mm by 430 mm (11 inches by 17 inches). Larger sheets shall be printed full scale.
 - .13 The procedure for shop drawing submissions shall be as follows:
 - .1 The Contractor shall assemble all required detail for each submission package, and stamp and initial the front of each page of the submission package. Each submission package shall be specific to a single specification section. Equipment from more than one specification section shall not be included in the same submission package. A separate transmittal form specific to each submission package shall be filled in and attached to the submission package.
 - .2 The Contractor shall review the shop drawings, stamp and initial the front of each page of the submission package, and sign the original transmittal form.
 - .3 The Contractor shall forward each shop drawing submission package to the Engineer.
 - .4 The Engineer will review each shop drawing submission package, stamp and initial the front of each page of the submission package.
 - .5 The Engineer will photocopy one set of shop drawings for his records.
 - .6 The Engineer will forward each submission package to the Contractor.
 - .7 The Contractor shall photocopy and distribute the entire reviewed shop drawing package to the appropriate trades and suppliers.
 - .8 The Contractor shall photocopy the appropriate number of sets for the Maintenance Documentation.
-

- .14 Samples: Submit samples in sizes and quantities specified.
- .15 Where colour is criterion, submit full range of colours.
- .16 Schedule submissions with adequate lead time for review by all concerned parties, before the dates when reviewed submissions are required for ordering of equipment.
- .17 Coordination of Submissions:
 - .1 Coordinate with field construction criteria.
 - .2 Coordinate each submittal with requirements of the work of all trades and Contract Documents.

37. Site Assessment

- .1 Refer to instructions to tenderers.
- .2 Visit the site before tendering and examine all local and existing conditions on which the work is dependent.
- .3 No consideration will be granted for any misunderstanding of work to be done resulting from failure to visit the site or insufficient site examination.

38. Site Conduct

- .1 All personnel on site must conduct themselves in a courteous and respectful manner with building occupants, owner's representative, members of the public, other trades, and any other individuals that may be on or near the site. Be aware that inappropriate conversation can be inadvertently overheard.
- .2 Construction issues are only to be discussed with consultants or other members of the design and construction team.
- .3 Avoid conversations or comments that may create undue concern among people unfamiliar with construction.
- .4 Personnel found to be using inappropriate site conduct must be removed from the site immediately.

39. Sleeves, Hangers, and Inserts

- .1 Provide and set sleeves where conduits pass through walls, floors or ceilings. Pack sleeves with material approved for use in fire separations.
- .2 Obtain Consultant's approval before cutting for sleeves.
- .3 Provide and install hangers and inserts where required.

40. Substantial Performance of the Work and Payment of the Holdback Procedures

- .1 Substantial Performance of the is defined in the Lien Legislation Applicable to the Place of the Work.
- .2 The project does not need to be Ready for Takeover to be declared Substantially Performed.
- .3 The value of the completed and approved work shall meet the criteria as set out in the Applicable Lien Legislation.
- .4 Prior to application for Certificate of Substantial Performance, carefully inspect the Work and ensure it is nearly complete, that major and minor construction deficiencies are complete, defects are corrected, and the building is clean and in condition for occupancy.
- .5 The contractor shall make application for Substantial Performance in writing to the consultant (acting as payment certifier). The Application is to include a comprehensive list of items which are to be completed or corrected.
- .6 Within 10 calendar days, the payment certifier and contractor shall visit site to determine if the value of the work meets the requirements on the Applicable Lien Act.

-
- .7 During the Substantial Performance Review a list of deficiencies and defects will be tabulated and values assigned for the sole determination of the Substantial Performance in relation to the Applicable Lien Act.
 - .8 If a certificate of completion is issued, then within 7 calendar days, the payment certifiers shall post the certificate:
 - .1 to the owner
 - .2 to the head contractor
 - .3 to all legal lien holders that have applied to the payment certifier in writing specifically for the certificate.
 - .4 on a prominent place on the improvement.
 - .9 Should the Consultant be required to repeat a Substantial Performance Review due to failure of the Work to comply with the claims of Substantial Performance made by the Contractor:
 - .1 Owner will compensate the Consultant for such additional services.
 - .2 Owner will deduct the amount of such compensation from the final payment to the Contractor.

41. Taxes

- .1 Pay all taxes levied by law, including Federal, Provincial, Municipal and Goods and Services Taxes.
- .2 Goods and Services Tax is to be shown as a separate item on all progress claims.

42. Temporary Heat

- .1 Refer to Division 1.
- .2 Do not use the permanent system for temporary heating purposes, during the construction period, without written permission from the Engineer.
- .3 Thoroughly clean and overhaul permanent equipment used during the construction period, replacing worn or damaged parts. Exchange equipment or components operating improperly at final review with new equipment or components.
- .4 Use of permanent systems for temporary heat shall not modify the terms of the warranty for all systems and equipment as specified elsewhere.
- .5 Operating heating systems under conditions which ensure no temporary or permanent damage. Operate fans at proper resistance with filters installed. Change filters at regular intervals. Operate with proper safety devices and controls installed and fully operational. Operate water systems with proper water treatment.
- .6 Where air systems are used during temporary heating, provide filter media on return and exhaust air inlets. Clean duct systems which have become dirty.

43. Temporary or Trial Usage

- .1 Temporary or trial usage by the Owner of mechanical equipment before Substantial Performance shall not represent acceptance.
- .2 Temporary use of mechanical systems and equipment for temporary heating service, either for construction or occupant benefit, before Substantial Performance shall not represent acceptance. Warranty periods shall not commence until the date of Substantial Performance.
- .3 Repair or replace permanent equipment used temporarily.
- .4 Take responsibility for damage caused by defective materials or workmanship during temporary or trial usage.

44. Time and Material Work and Cost Submittals

- .1 General:
 - .1 The Owner is more than willing to pay a fair price for fair work, but the Owner must be able to withstand a **Ministry Audit**, for **all** expenditures on a project.
 - .2 Time and Material Work can be initiated through either Change Notices or Cash Allowances but will ultimately be completed with Change Orders when the Work is complete.
 - .3 The Labor, Products and Construction Equipment Rental Rates are to consist of the actual costs as outlined in Change Directive Section of the CCDC 2.
 - .4 In the case of Cash Allowances, the Contractor's overhead and profit are included in the contract price, up to the value of the Cash Allowance.
 - .5 Any work that is considered defective and is rejected by the Consultant, will be corrected at the Contractor's expense.
- .2 Scope and Budget for Time and Material Work:
 - .1 The scope and budget for the work under the time and material method will be agreed to by the Contractor, Owner and Consultant and will be documented in a Change Notice or Cash Allowance.
- .3 Labor Rates:
 - .1 Labor Rates are to be submitted and approved by the Owner and Consultant, prior to the work associated with the rates starting.
- .4 Labor Cost Submittals:
 - .1 The Contractor shall keep a full, detailed and current account and records necessary for the documentation of all Labor costs. This requirement includes the work completed by Sub-Contractors.
 - .2 The account and records must be submitted on a period of two weeks to the Consultant, for review and approval. The submittal must be within 3 working days of the end of the two-week period.
 - .3 The Contractor and Sub-Contractors must provide labor timecards if requested by the Consultant.
 - .4 The Contractor shall keep the account current and records up to date. Labor claims submitted that are older than the two-week timeframe may be rejected at the sole discretion of the consultant.
- .5 Construction Equipment Rental Rates:
 - .1 Construction Equipment Rental Rates are to be submitted and approved by the Owner and Consultant, prior to the work associated with the rates starting.
- .6 Construction Equipment Rental Cost Submittals:
 - .1 The Contractor shall keep a full, detailed and current account and records necessary for the documentation of all Construction Equipment Rental Cost. This requirement includes Equipment Rentals by Sub-Contractors.
 - .2 The account, records and receipts must be submitted on a period of one weeks to the Consultant, for review and approval. The submittal must be within 3 working days of the end of the one-week period.
 - .3 Receipts for Equipment Rental Costs must be submitted when the equipment is returned, Weekly estimates of equipment cost shall be the supplied in the interim.
 - .4 The Contractor shall keep the account current and records up to date. Rental claims submitted that are older than the one-week timeframe may be rejected at the sole discretion of the Consultant.

- .5 Rental Equipment must be returned in a timely manner after the work that they are required for is complete.
- .7 Equipment and Material Cost Submittals:
 - .1 The Contractor shall keep a full, detailed and current account and records necessary for the documentation of all Equipment and Material Costs used in the installation of the work. This requirement includes Equipment and Material used by Sub-Contractors.
 - .2 The account, records and receipts must be submitted on a period of one weeks to the Consultant, for review and approval. The submittal must be within 3 working days of the end of the one-week period.
 - .3 Arrange for receipts to be only for this project alone. Receipts that include material for multiple projects are far to difficult to reconcile and can be rejected at the sole discretion of the Consultant.
 - .4 The Contractor shall keep the account current and records up to date. Equipment and Material claims submitted that are older than the one-week timeframe may be rejected at the sole discretion of the consultant.
 - .5 Allowances may be made for minor materials where quantities used would be too difficult to account for in a reasonable manner.
- .8 Milestones:
 - .1 50% Completion: the moment the value of the time and material achieves approximately 50% of agreed budget allowed for the work, the contractor shall notify the consultant and owner. A review of the installation will be done with the Contractor, Consultant and Owner, to determine if the work shall proceed as planned or if the scope of work needs to be adjusted to suit the budget that is available.
 - .2 80% Completion: the moment the value of the time and material achieves approximately 80% of agreed budget allowed for the work, the contractor shall stop the work and notify the Consultant and Owner. A review of the installation will be done with the Contractor, Consultant and Owner, to determine if the work shall proceed as planned or if the scope of work needs to be adjusted to suit the budget that is available.
 - .3 95% Completion: the moment the value of the time and material achieves approximately 95% of agreed budget allowed for the work, the Contractor shall stop the work and notify the Consultant and Owner. A review of the installation will be done with the Contractor, Consultant and Owner, to determine if the work shall proceed as planned or if the scope of work needs to be adjusted to suit the budget that is available.
 - .4 100% Completion: the moment the value of the time and material achieves the agreed budget allowed for the work, the contractor shall stop the work. Any costs over the budget shall be to the Contractor's expense.
- .9 Progress Draws:
 - .1 The value of the Time and Material Work approved is eligible to be included in progress payments.

45. Time of Completion

- .1 Commence work immediately upon official notification of acceptance of Tender and complete the Work as outlined in the Ready for Takeover Procedures as stated in the contract Documents.

46. Total Performance Reviews and Project Close Out

- .1 Prior to Total Performance provide a declaration, in writing, that deficiencies as noted on latest Review are not outstanding.
- .2 Notify the Consultant in writing that all deficiencies have been corrected and that the building is ready for Final Review.

- .3 Submit a final Statement of Account showing total adjusted Contract Price, previous payments and any other adjustments and monies due.
- .4 Submit a current Statutory Declaration.
- .5 Submit WorkSafeBC Certificate of Compliance.
- .6 Consultant will issue a final change order reflecting approved adjustments to contract price not previously made.
- .7 Should the Consultant be required to repeat a Total Performance Review due to failure of the Work to comply with the claims of Total Performance made by the Contractor:
 - .1 Owner will compensate the Consultant for such additional services.
 - .2 Owner will deduct the amount of such compensation from the final payment to the Contractor.

47. Trades Qualifications, Competency Assurance, Licenses

- .1 All workers engaged in the construction or renovation of systems or equipment, shall be journeymen who have Trades Qualifications under Province of British Columbia legislation, or are indentured apprentices working under a journeyman who is on the site.
- .2 All workers engaged in the construction or renovation of systems or equipment governed by other agencies such as the Federal or Provincial Ministry of Labour, Ministry of Health or the Ministry of Environment shall be appropriately licensed under Federal or Provincial legislation.
- .3 Tradesmen shall perform only work that their certificate permits.
- .4 Trades Qualification certificates or other licenses must be submitted prior to commencing work and must be on site for review.
- .5 Trades Qualifications or certificates or competency or licenses must be carried for workers including, but not limited to the following:
 - .1 Plumbing
 - .2 Gas fitting
 - .3 Pipe fitting

48. Workmanship

- .1 Standards of Workmanship shall be in accordance with well-established practices and standards accepted and recognized by the Engineer and the Trade.
- .2 Do not employ any unfit person or anyone unskilled in their required duties.
- .3 The Engineer shall have the right to reject any item of work that does not conform to the Contract Documents and accepted standards of performance, quietness of operation, finish and acceptance.

49. Warranty

- .1 Refer to Division 0 and Division 1.
- .2 The warranty period regarding the Contract, other than for latent defects, is limited to one year from the date of Ready for Takeover of the Work unless otherwise specified.
- .3 Provide warranty documentation for all equipment and materials as requested in the specification. Documentation to be placed in appropriate section of the Operating and Maintenance Manuals.
- .4 Correct any defects in the work due to faulty products or workmanship appearing within the warranty period.

- .5 The warranty shall not apply to work or other products damaged after Acceptance, by causes beyond the Contractor's control such as lack of prescribed maintenance, vandalism and abuse.
- .6 Correct and pay for any damage to other work resulting from any correction required under these conditions.
- .7 In the event that the repair time of defective equipment or systems is delayed for whatever reason, maintain the equipment or system in an approved manner until repairs can be made.

SECTION 20 00 41 – EQUIPMENT START-UP

1. GENERAL

1.1 Work Included

- .1 Starting and testing of equipment to provide a state of readiness for acceptance by Owner, and in complete accordance with the manufacturer's specific IOM startup instructions. Section supplements, but does not supersede, specific requirements of other Sections.
- .2 Completion of Equipment Startup forms and documentation as hereby outlined.
- .3 Re-tensioning all belt drive sets immediately prior to acceptance of the equipment by the Owner, and completion of the "Re-Tension Report for Belt Drives".

1.2 Definitions

- .1 **Unit:** Any item listed in the Mechanical Schedules, Section 20 00 05, that is composed of, or contains such sub-components that, as an integrated assembly, allow the unit to operate as specified. This includes any, or a combination of the following items:
 - .1 Direct drive fan and motor assembly
 - .2 Direct expansion cooling section with its various sub-components
 - .3 Gas fired heating section.
 - .4 Filter section
 - .5 Motorized dampers
- .2 **Start-Up:** The preparation, testing, and placing into operation of ALL units as described above in complete accordance with the manufacturers IOM.
- .3 **IOM:** Installation, Operation, and Maintenance Manual as produced by an equipment manufacturer or his designate and referring specifically to the unit in question. These manuals must contain a section or statements outlining the correct and proper placing of the equipment into operation (start-up).
- .4 **Equipment Startup Completion Certificates:** Certificates included in this section shall certify that the equipment in question has been started to the level outlined in the equipment manufacturers' IOM Manuals. Appended to the Certificate shall be copies or representations of the equipment manufacturer's Startup Instructions from their IOM manuals, which clearly designate the required startup procedures of that equipment as outlined by that manufacturer.
 - .1 If a unit contains a belt drive system, include a properly completed "Alignment Report for Belt Drives" along with the Equipment Startup Completion Certificate information.
- .5 **Alignment Report for Belt Drives** – This is a report for a belt drive system on a fan, which provides complete information on the alignment of that drive. It is intended to be completed by technicians trained in the correct alignment of the belt drive systems used on HVAC equipment. The technician must be able to provide as found and final data for the following information in the completion of the report:
 - .1 Unit Tag number
 - .2 Blower service – Supply fan, Return fan, Exhaust fan
 - .3 Belt size and quantity
 - .4 Drive sheave size and bushing or shaft size.
 - .5 Motor sheave size and bushing or shaft size.
 - .6 Drive alignment adjustments (angularity and axial offset)
 - .7 Belt tension force and distance adjustments, compared to manufacturers data
 - .8 Motor take-up allowance

1.3 Quality Assurance

- .1 When specified in individual Sections of Contract Documents, require manufacturer or supplier to provide authorized representative(s).
- .2 When authorized manufacturer representatives are not called for in individual Sections of Contract Documents, provide trained and qualified personnel to perform required equipment startup activities and tests, and alignment of any and all belt drive systems.

1.4 Safety

- .1 Ensure all requisite safety equipment, devices, detectors, materials, and procedures are in place, tested and operational before commencing.
- .2 Conform to requirements of all regulatory authorities having jurisdiction.
- .3 Maintain communications with fire, police, environmental and health authorities.

1.5 Environmental Protection

- .1 Comply with all requirements of Federal, Provincial and Local Jurisdictions having authority.

1.6 Submittals – Prior to Start-up

- .1 Qualifications of technicians installing, testing and reporting test results.
- .2 The start-up technician shall have copies of the required start-up procedures and have a copy of the “Equipment Startup Certificate” for each unit to be started up.
- .3 If the unit being started also has a belt drive system, then the technician must complete.

1.7 Submittals – Prior to Substantial Performance

- .1 Provide completed Start-Up Completion Certificates complete with attached Manufacturer IOM Startup Procedures for inclusion in Operating and Maintenance Manuals.

1.8 Liability

- .1 During tests, assume responsibility for damages in the event of injury to personnel, building or equipment and bear costs for liability, repairs and restoration.

2. PRODUCTS

2.1 Startup Completion Certificates

20 00 41-A EQUIPMENT STARTUP CERTIFICATE											
Project:											
Location:											
Contractor:											
Equipment Tag #:											
Equipment Description:											
Specification Section:											
Supplier of Equipment Item:											
Manufacturer's IOM Startup instructions number of pages attached:											
<p>The undersigned Start-up Technician of the equipment item described above hereby certifies that he/she has:</p> <ol style="list-style-type: none"> 1. Possession of the particular start-up documentation from the manufacturer's IOM prior to the beginning of any startup activities. 2. Has all of the required test equipment to perform the startup activities, and that the test equipment has recently been calibrated. 3. Performed the start-up of the equipment. 4. The equipment has been Started / Field Tested in accordance with the manufacturer's recommendations as attached. 5. The Undersigned also affirms that he/she is appropriately qualified to perform the startup activities as described by the manufacturer's IOM. 											
<p>Comments:</p> <table border="1" style="width: 100%; border-collapse: collapse;"> <tr><td> </td></tr> <tr><td> </td></tr> <tr><td> </td></tr> <tr><td> </td></tr> <tr><td> </td></tr> <tr><td> </td></tr> <tr><td> </td></tr> <tr><td> </td></tr> <tr><td> </td></tr> <tr><td> </td></tr> </table>											
Technician Name:											
Representing:											
Date:											
Signature:											

3. EXECUTION

3.1 Equipment Start-Up:

- .1 Provide all required testing equipment and ancillary equipment to complete the required equipment start-up in accordance with manufacturer's start-up requirements.
- .2 Calibrate all test equipment to plus or minus 2 percent of actual value at full scale. Prove calibration if requested by Engineer.
- .3 Employ recognized, industry standard calibration procedures or as specified in individual Sections.

-
- .4 Submit calibration plans and results to Engineer.
 - .5 Attend and participate in any Pre-start-up, Start-up and Commissioning workshops with Engineer and Owner representatives.
 - .6 Contractor shall obtain copies of the equipment manufacturer's IOM startup procedures prior to the initiation of any equipment start-up activities. The contractor shall be familiar with all of the required start-up activities contained therein.
 - .7 Contractor shall conduct performance tests of all equipment in conjunction with the manufacturers' representatives as required by the Contract Documents and subject to witness by the Engineer or his designate.
 - .8 Deficiencies that are uncovered shall be corrected and retesting shall be conducted as required.
 - .9 "Equipment Start-Up Completion Certificates" shall be prepared by Contractor certifying that the equipment start-up is complete, successfully tested, and ready for balancing or placing into final operation in the event that balancing activities are not required.
 - .10 Start-up of equipment shall be completed, and copies of Equipment Start-Up Certificates submitted to the balancing agency prior to the commencement of balancing activities.

SECTION 20 00 42 – TESTING

1. GENERAL

1.1 Work Included

- .1 Test and report of new heating, and ventilation systems specified, renovated or modified under Division 20.
- .2 Test and report of new plumbing systems specified, renovated or modified under Division 20.

1.2 Quality Assurance

- .1 Test equipment and material where specified required by authority having jurisdiction to demonstrate its proper and safe operation.
- .2 Test procedures shall be in accordance with applicable portions of:
 - .1 CSA B149.1 Natural Gas and Propane Installation Code.
 - .2 BC Municipal Affairs Engineering Services Division
 - .3 BC Plumbing Code
 - .4 National Fire Protection Association
 - .5 American Society of Heating, Refrigeration and Air Conditioning Engineers
 - .6 Sheet Metal and Air Conditioning National Association
 - .7 American Society of Mechanical Engineers
 - .8 Local codes and ordinances
 - .9 Other recognized test codes
- .3 Provide two days notice to the Engineer before tests.

1.3 Submittals – Prior to Substantial Performance

- .1 Obtain certificates of approval and acceptance from authorities having jurisdiction and include in Operating and Maintenance Manuals.
- .2 On completion of mechanical installation, provide certification of tests with detailed data as required. Itemize tests as to time performed and personnel responsible. Include a copy of field data in Operating and Maintenance Manuals.

1.4 Liability

- .1 During tests, assume responsibility for damages in the event of injury to personnel, building or equipment and bear costs for liability, repairs and restoration.

2. PRODUCTS - Not Applicable.

3. EXECUTION

3.1 Pressure Tests

- .1 Piping, fixtures or equipment shall not be concealed or covered until inspected and reviewed by the Engineer.
- .2 Provide equipment, materials and labour for tests. Use test instruments from approved laboratory or manufacturer and furnish certificate showing degree of accuracy. Install permanent gauges and thermometers just prior to tests to avoid changes in calibration.
- .3 Carry out pressure and hydraulic tests for 8 hours and maintain pressure. Where leakage occurs, repair and retest.
- .4 Drainage Systems: Test by filling with water to produce water pressure of 30 kPa (3,000 mm) minimum and 75 kPa (8,000 mm) maximum. Check for proper grade and obstruction by ball test, or other approved means.

-
- .5 Natural Gas Piping: Test as required by authority having jurisdiction.
 - .6 Low Pressure Ducts: Test for tightness such that leakage is inaudible and not detectable by feel.
 - .7 Should tests indicate defective work or variance with specified requirements, make changes immediately to correct the defects. Correct leaks by remaking joints in screwed fittings, cutting out and re-welding welded joints, remaking joints in copper lines. Do not caulk.

3.2 Performance Tests

- .1 Provide fresh filters for all air handling equipment prior to testing or balancing.
- .2 Use or modify manufacturers' reports. Test and adjust equipment and systems as specified, and as required by the manufacturer. Ensure that manufacturers' start up reports are complete and acceptable.
- .3 Provide detailed listing of equipment set up parameters "as left."
- .4 Make operating tests for minimum of five days during heating season of first year of operation and at times when directed, for proper setting of controls under peak load conditions.
- .5 Conduct final operating tests in presence of the Owner. Vary loads to illustrate start-up and shutdown sequence, and simulate emergency conditions for safety shutdowns, with automatic and manual reset. Make final adjustments to suit exact building conditions.
- .6 Provide labour, ladders, tools and associated equipment required to assist in all tests.

3.3 Carbon Monoxide Detection System

- .1 Conduct commissioning operations and tests to confirm the detection systems are properly installed, calibrated and operational.

SECTION 20 00 45 – DOCUMENTATION, MANUALS AND RECORD DRAWINGS

1. GENERAL

1.1 Work Included

- .1 Operating and Maintenance Manuals.
- .2 Assembly of equipment start up and performance tests and reports for new, renovated or necessary existing systems.
- .3 Assembly of equipment details sheets and shop drawings for new, renovated or necessary existing systems.
- .4 Assembly of equipment and systems operating and maintenance instructions for new, renovated or necessary existing systems.
- .5 Assembly of final permits for new, renovated or necessary existing systems.
- .6 Record Drawings.
- .7 Cost of updating drawings to Record Drawing status, with all field changes, Addendum items, Post Tender Addendum items and all Change Orders.

1.2 Acceptable Agencies

- .1 Agencies who are approved in principle, but subject to requirements of drawings and specifications are:
 - .1 R. A. Bruce & Associates, Kelowna.
 - .2 Westar Technologies, Kelowna
 - .3 Inland Technical Services Ltd., Kelowna.

2. PRODUCTS

2.1 Operation and Maintenance Materials

- .1 Provide one hard copy in a 215 mm x 280 mm 3 post type catalogue binder, lettering front and spine, plastic tab dividers. Binder should be identified by both volumes if required.
- .2 Provide one readable/writable USB memory device labelled and containing the specified materials in Portable Document Format (PDF).
- .3 Manufacturers' data section is to be indexed and ordered to exactly match the sections of the specifications, including section numbering. Each section of the manufacturers' data section is to include an up-to-date copy of the equipment schedule for that section, with the same format as the equipment schedules in the tender document. The schedule is to be revised to suit all addenda, change orders and field changes, as well as manufacturers and model numbers matching the equipment supplied. Assemble or develop complete and correct documentation for the operation and preventative maintenance of equipment and systems provided.
- .4 Assemble or develop copies of all certified shop drawings and material required to complete the documentation. This generally includes but is not limited to the following:
 - .1 Comprehensive description of the operation of the systems, including the function of each item of equipment within the system.
 - .2 Permits
 - .1 Plumbing
 - .2 Gas
 - .3 Detailed instructions for the normal maintenance of all systems and equipment installed including procedures and frequency of operational checks and service and troubleshooting instructions.

- .4 Operating and maintenance schedule, indicating location, grades (grease or oil) for all lubricated equipment components.
- .5 Local source of supply for each item of equipment.
- .6 Shop drawings, including the Engineer's review stamp and comments.
- .7 Labelling and identification schedule.
- .8 Valve schedule, including location, service and normal position.
- .9 Air system balance report.
- .10 Equipment start up reports as per manufacturer requirements.
- .11 Equipment start up reports to detail as left settings.
- .12 Buried gas pipe covering test report.
- .13 Warranties, certificates and miscellaneous reports.
- .14 Manufacturers' operating and maintenance brochures, and shop drawings, including wiring diagrams, fan performance data, pump curves with the operating point indicated, and control maintenance bulletins.
- .15 Filter type, specification, model number, efficiency rating, and thickness, correlated with air handling equipment identification.
- .16 Completed equipment inventory and submittal sheets.
- .17 Statutory Inspection details.
- .18 Control device setting record sheets.
- .19 Carbon monoxide detection system calibration and testing report.
- .20 Letters of assurance from Seismic Engineer.
- .21 Instructions for emergency operation, maintenance and shutdown of all systems.
- .22 Record Drawings photo reduced to 430 mm x 280 mm.
- .23 Copies of all Receipts for equipment handed over to the Owner.

2.2 Record Drawings

- .1 Contractors shall certify final reproducible Record Drawings to be correct by notation and signature on the drawings.
- .2 Record drawings shall precisely identify the configuration, size and location of all systems and equipment installed under this Division.
- .3 Before Substantial Performance submit for approval to the Engineer, completed and detailed marked up white prints to reflect the record drawing status.
- .4 A Cash Allowance has been specified to cover the Consultant's cost of the following:
 - .1 Updating the original computer software to include all changes recorded on the record white prints.
 - .2 Plotting one set of full-size reproducible record drawings.
- .5 The Consultant shall distribute the following record materials provided under the Cash Allowance.
 - .1 One set of full size white printed Division 20 record drawings.
 - .2 One set of reduced size Division 20 record drawings bound in each Maintenance Manual.
 - .3 One set of full-size reproducible Division 20 record drawings to the Engineer.

2.3 Balance Reports

- .1 Refer to Section 20 00 43, Balancing.
- .2 Provide specified number of final copies for inclusion in Operating and Maintenance Manuals.

2.4 Permits

- .1 Refer to Section 20 00 42, Testing and Section 20 00 10, General Mechanical Provisions.

2.5 Equipment Test Reports

- .1 Refer to Section 20 00 43, Balancing.

3. EXECUTION

3.1 Maintenance Manuals

- .1 Substantial Performance cannot be declared until reviewed Manuals are in the hands of the Owner.
- .2 Submit a draft copy of proposed content, including comprehensive systems description, for approval prior to Substantial Performance.
- .3 Provide one corrected and final copy of the Maintenance Manual along with an electronic version (CD Read-Write or flash drive) of the maintenance manual, to the Engineer at least five days prior to Substantial Performance.

3.2 Record Drawings

- .1 The contractor is to maintain on site a clean set of drawings to be used to mark on any changes made during the course of construction. Changes must be kept up to date on a daily basis.

SECTION 20 00 60 – PIPE AND PIPE FITTINGS

1. GENERAL

1.1 Work Included

- .1 Renovations to existing sanitary and storm drainage and vent piping.
- .2 Renovations to existing natural gas piping.

1.2 Welding

- .1 Welding materials and labour shall conform to ASME Code and the Provincial Regulations.
- .2 Use welders fully qualified and licensed by Provincial Authorities.

1.3 Quality Assurance

- .1 Fuel piping shall meet the requirements of proper CSA Standard Installation Code for Oil or Gas Burning Appliances and Equipment.
- .2 Domestic water, drainage and vent piping shall meet the requirements of the British Columbia Building Code, British Columbia Plumbing Code, and Municipal Codes.
- .3 Septic System piping shall meet the requirements of the B.C. Ministry of Health.
- .4 Pipe fittings shall conform to the following standards:
 - .1 ANSI/ASME B1.20.1-2013(R2018) (Pipe Threads)
 - .2 ASTM-A197-2019 (Materials)
 - .3 ANSI B16.3-2020 (Valves – Flanged – Threaded and Welded Ends)
 - .4 JIS B 2301-2013 (Screwed Type Malleable Cast Iron Pipe Fittings)
 - .5 JIS H 8641-2007 (Zinc Hot Dip Galvanizing)
 - .6 JIS G 5705-2000 (Malleable Iron Castings)
 - .7 ASME-B31.9-2020 (Building Service Piping)

1.4 Acceptable Manufacturers

- .1 Manufacturers of groove and clamp pipe fittings whose products are approved in principle, but subject to requirements of drawings and specifications are:
 - .1 Victaulic

1.5 Submittals – Prior to Construction

- .1 Pipe Fittings: Submit one sample piece for each type of fitting including but not limited to screwed, welded or clamped elbows, tees, flanges and couplings.
- .2 Grooved coupling Gaskets: Full technical information including but not limited to material, service temperature, installation instructions, identification, compatibility with proposed coupling hardware, etc.
- .3 Mechanical Joint Couplings: Listed to CAN/ULC S102.2-10 & CSA-B602.

2. PRODUCTS

2.1 Pipe - Service & Material

- .1 Equipment Drains and Overflows:
 - .1 Material: Galvanized Steel Schedule 40
 - .1 Fittings: Galvanized - threaded
 - .2 Material: Type K or L Hard Copper
 - .1 Fittings: Wrought copper, cast brass - 50/50 solder
 - .2 Fittings: Cast brass - threaded

-
- .3 Material: PVC schedule 40
 - .1 Fittings: PVC - solvent weld
 - .2 Sanitary Drainage and Vent (above grade including crawlspace):
 - .1 Material: Type M or DWV Copper
 - .1 Fittings: Wrought copper, cast brass - 50/50 solder
 - .2 Material: Cast Iron
 - .1 Fittings: Mechanical joint
 - .3 Material: PVC System
 - .1 Fittings: PVC - solvent weld
 - .3 Sanitary Drainage and Vent (buried under building):
 - .1 Material: ABS Solid Core, PVC (CSA Approved) up to 6"
 - .1 Fittings: ABS Solid Core, PVC - solvent weld
 - .2 Material: SDR 35 PVC (CSA Approved)
 - .1 Fittings: gasketed hub and spigot
 - .4 Storm Drainage (above grade including crawlspace):
 - .1 Material: Type M or DWV Copper
 - .1 Fittings: Wrought copper, cast brass
 - .2 Material: PVC System 15 or equal for non-plenum application. Flame spread rating shall be 25 or less.
 - .1 Fittings: PVC solvent weld, System 15 or equal as approved by piping manufacturer
 - .3 Material: PVC System XFR or equal for plenum application. Flame spread rating shall be 25 or less and smoke development rating shall be 50 or less.
 - .1 Fittings: PVC solvent weld, System XFR or equal as approved by piping manufacturer
 - .5 Storm Sewer (buried under building):
 - .1 Material: ABS Solid Core, PVC (CSA Approved)
 - .1 Fittings: ABS Solid Core, PVC - solvent weld
 - .2 Material: SDR 35 PVC (CSA Approved)
 - .1 Fittings: gasketed hub and spigot
 - .6 Radon Vent:
 - .1 Material: PVC System 15 or equal for non-plenum application. Flame spread rating shall be 25 or less.
 - .1 Fittings: PVC solvent weld, System 15 or equal as approved by piping manufacturer
 - .2 Material: PVC System XFR or equal for plenum application. Flame spread rating shall be 25 or less and smoke development rating shall be 50 or less.
 - .1 Fittings: PVC solvent weld, System XFR or equal as approved by piping manufacturer
 - .7 Natural Gas (above grade):
 - .1 Material: Steel Schedule 40
 - .1 Fittings: Malleable steel - threaded under 63 mm if approved
 - .2 Fittings: Forged steel - welded 63 mm and over and where required by service
 - .3 Press type fittings are not permitted.
 - .4 Flexible corrugated piping of aluminum or any other material is not acceptable, except at the final connection to equipment.
-

- .8 Natural Gas (underground):
 - .1 Material: Polyethylene
 - .1 Fittings: Thermal bonded
- .9 Foundation Drains:
 - .1 Material: ABS or PVC schedule 40 (perforated)
 - .1 Fittings: Hub and spigot

2.2 Unions

- .1 Size 51 and under: 1035 kPa (150 psi) malleable iron, bronze to iron ground joint unions for threaded ferrous piping, air tested for gas service, all bronze for copper piping.
- .2 Sizes 64 mm and over: 1035 kPa (150 psi) forged steel slip on flanges for ferrous piping, 150 lb. bronze flanges for copper piping. Gaskets shall be 1.6 mm thick performed synthetic rubber bonded fibre material. Gaskets for gas service shall be synthetic rubber.
- .3 Unions and flanges are not required for servicing and disconnect in systems that use grooved couplings. In these systems, the grooved coupling will act as a disconnect point for servicing.

2.3 Strainers

- .1 Size 51 mm and under: Screwed or grooved, brass, or iron body, Y pattern with 0.8 mm stainless steel perforated screen.
- .2 Size 64 mm to 102 mm: Flanged or grooved iron body, Y pattern with 1.2 mm stainless steel perforated screen.
- .3 Size 127 mm and larger: Flanged or grooved iron body, basket pattern with 3 mm stainless steel perforated screen.
- .4 Screen free area shall be minimum three times area of inlet pipe. Provide valved drain and hose connection off strainer bottom.

2.4 Solder

- .1 Potable water systems have lead content less than 0.2%.

2.5 Flanges

- .1 Forged steel, 125 pound, slip on or weld neck configuration.

2.6 Overflow Drain Spout

- .1 Cast bronze, lip extension, full face plate and wall flange.
- .2 Equal to Zurn ZAB-199.

3. EXECUTION

3.1 General

- .1 Make connections to equipment and branch mains with unions.
- .2 Provide non-conducting type connections wherever jointing dissimilar metals.
- .3 Do not run combustible or non-approved pipe through fire separations. Use approved materials and methods only.
- .4 Install piping to allow for expansion and contraction without unduly stressing pipe or equipment connected.
- .5 Provide clearance for proper installation of insulation and for access to valves, air vents, drains and unions.

3.2 Existing Systems

- .1 Relocate existing services and piping systems to suit new work. Determine the extent of the requirements by inspection of the site and conditions.

- .2 Relocate existing systems and components as required to allow for installation of new or renovated systems.

3.3 Preparation

- .1 Ream pipes and tubes. Clean off scale and dirt, inside and outside, before assembling. Remove welding slag or other foreign material from piping.

3.4 Steel Pipe Connection

- .1 Screw joint steel piping up to and including 38 mm. Screw or weld 51 mm piping. Weld piping 64 mm and larger, including branch connections.
- .2 Make screwed joints with standard NPT configuration. Use teflon tape.
- .3 Use full sized tees or main sized saddle type branch connections for directly connecting branch lines to mains in steel piping. Do not project branch pipes inside the main pipe.
- .4 Make reductions in large water pipes with eccentric reducing fittings installed to provide drainage and venting.

3.5 Grooved Mechanical Couplings

- .1 Use grooved mechanical coupling and mechanical fasteners only in accessible locations.
- .2 Use grooved mechanical coupling to engage and lock grooved or shouldered pipe ends. Use flexible grooved fittings where required to allow for some angular deflection, contraction and expansion.

3.6 Grades, Routes and Installations

- .1 Route piping in orderly manner and maintain proper grades. Install to conserve headroom and interfere as little as possible with use of space.
- .2 Run exposed piping parallel to walls. Group piping wherever practical at common elevations.
- .3 Install concealed pipes close to the building structure to keep furring to a minimum.
- .4 On closed systems, equip low points with 19 mm drain valves and hose connection.
- .5 At high points, provide collecting chambers and high-capacity float operated automatic air vents.

3.7 Underground Natural Gas Piping

- .1 Provide approved polyethylene re-wrap on welded joints or where protective jacket has been damaged.
- .2 Provide anode and corrosion protection as required by codes.

3.8 Foundation Drains

- .1 Install drains in locations shown. Arrange to drain to storm system.
- .2 Refer to detail on architectural drawings for position and reference to footings.

3.9 Priming

- .1 Prime coat exposed pipe, pipe hangers and supports. Pipes, pipe hangers and supports located in crawlspaces, pipe shafts and suspended ceiling spaces are not considered exposed.

SECTION 20 00 90 – SUPPORTS and ANCHORS

1. GENERAL

1.1 Work Included

- .1 Pipe hangers and supports.
- .2 Duct hangers and supports.

1.2 Quality Assurance

- .1 Plumbing pipe supports shall meet the requirements of BC Plumbing Code.
- .2 Natural gas pipe supports shall meet the requirements of CSA B 149.1 Installation Code for Natural Gas Fired Appliances.
- .3 Duct hangers shall follow the recommendations of the SMACNA Duct Manuals.

2. PRODUCTS

2.1 Pipe Hangers and Supports

- .1 Hangers:
 - .1 Pipe Sizes 13 mm to 38 mm: Adjustable wrought steel ring, or plated strap.
 - .2 Pipe Sizes 51 mm and over: Adjustable wrought steel clevis.
- .2 Multiple or Trapeze Hangers: Steel channels with welded spacers and hanger rods, cast iron roll and stand for hot pipe sizes 152 mm and over.
- .3 Wall Support:
 - .1 Pipe Sizes to 75 mm: Cast iron hook, or fabricated bracket of 25 mm x 25 mm x 6 mm angle bar.
 - .2 Pipe Sizes 100 mm and Over: Welded steel bracket and wrought steel clamp.
- .4 Vertical Support: Steel riser clamp.

2.2 Hanger Rods

- .1 Provide steel hanger rods, threaded both ends, or continuous threaded, complete with lock nuts on both ends.

2.3 Duct Hangers and Supports

- .1 Hangers:
 - .1 Concealed - Round Duct: Galvanized steel band iron.
 - .2 Concealed - Rectangular Duct: Galvanized steel band iron or rolled angle and 9 mm rods.
 - .3 Exposed - Round Duct: Continuous galvanized steel band iron secured to single 9 mm hanger rod.
- .2 Wall Supports: Galvanized steel band iron or fabricated angle brackets.
- .3 Vertical Support at Floor: Rolled angle.

2.4 Inserts

- .1 Inserts shall be malleable iron case or galvanized steel shell and expander plug for threaded connection with lateral adjustment, top slot for reinforcing rods, lugs for attaching to forms.
- .2 Size inserts to suit threaded hanger rods.

3. EXECUTION

3.1 General Requirements

- .1 Provide hangers and supports to secure equipment in place, prevent vibration, maintain grade, provide for expansion and contraction.
- .2 Install supports of strength and rigidity to suit loading without unduly stressing building. Locate adjacent to equipment to prevent undue stresses in piping and equipment.
- .3 Select hangers and supports for the service and in accordance with the manufacturer's recommended maximum loading. Hangers shall have a safety factor of 5 to 1.
- .4 Do not cut, drill or weld to structural elements without prior approval from the engineer.
- .5 Perforated metal strapping is not an acceptable means of supporting piping, ducting or mechanical equipment.

3.2 Pipe Hangers and Support

- .1 Fasten hangers and supports to building structure or inserts in concrete construction.
- .2 The horizontal pipe support table listed below does not apply to domestic water, drainage or vent piping. Refer to the Plumbing Code support spacing for these piping services.
- .3 Support horizontal steel piping as follows:

Nominal Pipe Size	Distance Between Supports	Hanger Rod Diameter
.1 0 in to 0.5 in	6 ft.	0.375 in
.2 0.75 in to 1.5 in	6 ft.	0.375 in
.3 2.0 in to 2.5 in	6 ft.	0.5 in
.4 3.0 in to 4.0 in	6 ft.	0.5 in
.5 6.0 in to 12 in	12 ft.	0.5 in
.6 14 in and over	12 ft.	1.0 in
- .4 Install hangers to provide minimum 15 mm clear space between finished covering and adjacent work.
- .5 Place a hanger within 300 mm of each horizontal elbow.
- .6 Use hangers which are vertically adjustable 40 mm minimum after piping is erected.
- .7 Support vertical piping at every floor. Support vertical soil pipe at each joint.
- .8 Where several pipes can be installed in parallel and at same elevation, provide multiple or trapeze hangers.
- .9 Where practical, support riser piping independently of connected horizontal piping.
- .10 Support horizontal soil pipe near each joint, with 1,500 mm maximum spacing between hangers.
- .11 Support plastic piping at intervals one half the distances shown in 3.2.2, or less if required to prevent deformation.
- .12 Exposed piping, with less than 2,700 mm clearance to floors shall be provided with two times the number of hangers normally required. Spacing shall be equal or adjusted for maximum benefit.
- .13 Provide copper plated hangers and supports for copper piping or provide nonferrous packing between hanger or support and piping.
- .14 Large capacity piping with vibration potential shall not be suspended from any building structure that will allow transfer of vibrations to the occupied spaces.

3.3 Priming and Coating

- .1 Prime coat exposed steel hangers and supports. Hangers and supports located in crawlspaces, pipe shafts and suspended ceiling spaces are not considered exposed.

3.4 Equipment Bases and Supports

- .1 Concrete housekeeping pads are specified under other divisions of the specification. Bases shall be 100 mm thick minimum, extended 100 mm minimum beyond machinery bedplates. This Division will provide templates anchor bolts and accessories required for mounting and anchoring equipment.
- .2 Construct supports of structural steel members or steel pipe and fittings. Brace and fasten with flanges bolted to structure.
- .3 Provide rigid anchors for ducts and pipes immediately after vibration connections to equipment.
- .4 Suspend mechanical equipment from structure with adjustable length steel rods. Provide spreader beams to distribute weight.

3.5 Inserts

- .1 Use inserts for suspending hangers from reinforced concrete slabs and sides of reinforced concrete beams wherever practicable.
- .2 Set inserts in position in advance of concrete work. Provide reinforcement rod in concrete for inserts carrying pipe over 102 mm or ducts over 1,500 mm wide.
- .3 Where concrete slabs form finished ceiling, finish inserts flush with slab surface.
- .4 Where inserts are omitted, drill through concrete slab from below and provide rod with recessed square steel plate and nut above slab.
- .5 Expansion bolt type connections will be approved under certain conditions. Obtain approval from the Engineer. Generally pipe 51 mm or smaller, and duct less than 600 mm x 300 mm will be approved, subject to adequate number of support points.

3.6 Exposed Duct Support

- .1 Supply and return ducts exposed in the finished areas are to be supported by continuous strap installed around the duct. Only one joint on the strap is approved, at the top to secure the strap ends together and to connect to a threaded rod.
- .2 The threaded rod shall be secured to trusses or to steel angle bars spanning the trusses. The steel spanning bars are to be provided by this division.
- .3 Supports for equipment suspended within the space frame, are to be connected to the bolted node joints of the space frames. The locations of duct and piping suspension connections to the node joints must be coordinated and installed before the space frames are assembled and lifted to position. Refer to detail.
- .4 Supports for equipment supported above the space frame, may be connected to the bolted node joints of the space frames, or from the fluted steel deck above. The locations of duct and piping suspension connections to the node joints must be coordinated and installed before the space frames are assembled and lifted to position. Refer to detail.

SECTION 20 00 95 – SLEEVES, FLASHING AND SEALS

1. GENERAL

1.1 Work Included

- .1 Flashing for mechanical equipment.
- .2 Sleeving for mechanical equipment.
- .3 Fire stop seals.

1.2 Quality Assurance - Firestop Sealants

- .1 Standard method of fire tests : CAN4-S115-M85, ASTM E814, UL1479, UL 2079.
- .2 Materials shall be listed by FM and certified by UL or ULC for the service application.

1.3 Quality Assurance - Firestop Collars

- .1 Standard method of fire tests : CAN4-S115-M85, ASTM E814, UL1479, UL 2079.
- .2 Seals, assemblies and materials for penetration of fire rated surfaces shall be listed by FM and certified by UL or ULC for the service application.

1.4 Submittals – Prior to Construction

- .1 Firestop materials: Submit service limitations, installation instructions, UL certification and FM listing.
- .2 Fire rated penetration seals: Submit dimensional data, service limitations, installation instructions, UL certification and FM listing.

1.5 Acceptable Manufacturers

- .1 Manufacturers of fire stopping materials whose products are approved in principle, but subject to requirements of drawings and specifications are:
 - .1 Self Seal, Hilti, 3M.

2. PRODUCTS

2.1 Sleeves - Pipe

- .1 Domestic water, gas, drainage, etc.: Pipes through beams, wall, fireproofing, footings, floor: Form with steel pipe, schedule 20, galvanized.
- .2 Underground sleeve for gas pipe: PVC or other approved non-metallic material, minimum diameter 25 mm greater than outside diameter of gas pipe.

2.2 Roof Jacks and Vent Caps

- .1 Vent caps: Aluminum.

2.3 Flashing

- .1 Aluminum flashing: 26-gauge sheet aluminum.

2.4 Firestop Sealant

- .1 Tested and rated for PVC conduit, polyethylene conduit or pipe, other non-metallic pipes, cables, and combustible pipe insulations as the penetrant.
- .2 Single component, low modulus flexible sealant to form pressure tight seal resistant to water, smoke and toxic gases, resistant to cracking, degradation by ultraviolet radiation and ozone.
- .3 Compatible with construction materials of galvanized steel, aluminum, concrete, gypsum board.
- .4 Contain no water-soluble expansion ingredients.

- .5 Wall and floor openings: equal to Self Seal GG-200.
- .6 Floor openings: equal to Self Seal SL-100.

3. EXECUTION

3.1 Sleeves

- .1 Provide and set sleeves required for equipment, including openings required for placing equipment.
- .2 Set sleeves in position in advance of other work. Provide suitable reinforcing around sleeves.
- .3 Extend sleeves through potentially wet floors 50 mm above finished floor level. Caulk sleeves full depth and provide floor plate.
- .4 Where piping passes through floor, ceiling or wall, close off space between pipe and sleeve with non-combustible insulation or approved non-combustible insulation, fire rated as required to match the rating of the penetrated surface. Provide tight fitting metal caps on both sides.
- .5 Install chrome plated escutcheons where piping passes through finished surfaces.
- .6 Size large enough to allow for movement due to settlement, expansion and to provide for continuous insulation.
- .7 Sleeves penetrating vapour barriers shall be securely tape sealed at all penetrations.

3.2 Flashing

- .1 Where mechanical equipment passes through weather or waterproofed walls and roofs, counter flashing shall be provided under this Division. Roof flashing is specified under other divisions of this specification.

3.3 Roof Jacks

- .1 Provide roof jacks as required, and in compliance with the roofing specifications. Generally, SBS torch down roofing requires aluminum roof jacks. Conventional bituminous roofing accepts aluminum roof jacks.
- .2 Flash vent and soil pipes projecting above finished roof surface with approved material.
- .3 Plumbing vents: aluminum flashing cap.
- .4 Piping projecting through the roof, including gas, shall be provided with approved roof jack and coupling seal or storm collar. Apply silicone sealant at top and bottom of coupling seal or storm collar.

3.4 Firestop Sealant

- .1 Apply in conjunction with manufacturer's instructions and all related codes.
- .2 Clean all concrete, masonry and stone penetrations of all contaminants and impurities, concrete form release agents, water repellents, oils, surface dirt and rust, scale, all old sealants and other surface treatments.
- .3 Metal surfaces shall be cleaned by wiping them with an oil-free absorbent cloth saturated with solvent such as xylol or toluol. Do not use alcohols.
- .4 Pack voids with approved, non-combustible void filling material, recessed the appropriate dimension and fill the cavity with approved sealant. Prime mating surfaces if necessary.
- .5 Installation only when temperatures are between 5 degrees Celsius and 35 degrees Celsius.

SECTION 20 10 00 – VALVES

1. GENERAL

1.1 Work Included

- .1 Ball valves.
- .2 Relief valves.
- .3 Drain valves.
- .4 Pressure regulating valves - gas.
- .5 Vacuum breakers.
- .6 Solenoid operated natural gas valve.

1.2 Manufacturer

- .1 Provide valves of same manufacturer throughout where possible.
- .2 Provide valves with manufacturer's name and pressure rating clearly marked on outside of body.

1.3 Quality Assurance

- .1 Valves for gas service shall be trimmed and approved for specified service.

1.4 Submittals – Prior to Construction

- .1 Manufacturers' data and shop drawings for all valves and accessories including dimensions, pressure ratings, materials, service acceptability.
- .2 Manufacturers' data, shop drawings and instructions for backflow preventer testing equipment including dimensions, pressure ratings, materials, service acceptability.
- .3 Pressure Regulating Valves - Natural Gas: Manufacturers' data and shop drawings for valves and accessories including dimensions, pressure ratings, materials, configuration and service acceptability.

1.5 Submittals – Prior to Substantial Performance

- .1 Relief valves – Provide a test report with photographs confirming that each relief valve seats correctly without leaking and does not splash or cause flooding at the discharge.

1.6 Acceptable Manufacturers

- .1 Manufacturers of natural gas pressure regulating valves whose products are approved in principle, but subject to requirements of drawings and specifications are:
 - .1 Pietro Fiorentini, Fisher.
- .2 Manufacturers of valves for grooved pipe whose products are approved in principle, but subject to requirements of drawings and specifications are:
 - .1 Victaulic

2. PRODUCTS

2.1 Valve Connections

- .1 Provide valves suitable to connect to adjoining piping as specified for pipe joints. Use pipe size valves.
- .2 Thread pipe sizes 51 mm and smaller.
- .3 Flange pipe sizes 64 mm and larger.
- .4 Solder or screw to solder adaptors for copper piping.
- .5 Use grooved body valves with mechanical grooved jointed piping.

2.2 Pressure Reducing Valves - Natural Gas – Non-Boiler Service

- .1 Metal body, composition rubber diaphragm, plated or stainless-steel spring, internal strainer.

2.3 Relief Valves

- .1 Provide ASME rated direct spring-loaded type, lever operated nonadjustable factory set discharge pressure as indicated.

2.4 Ball Valves

- .1 Up to 64 mm: Forged bronze body, delrin seat and seals, chrome plated ball, forged steel pin, screwed ends, 1200 kPa (175 psig) WOG.
- .2 Tail piece supply isolation valves: ball type valves, angle configuration, screwdriver operated, compression fittings or threaded as required, chrome plated if exposed.
- .3 Where piping systems are insulated, ball valves shall include stem extensions to raise the handles above the level of the insulation. Valve handles shall not be bent to accommodate insulation clearances.

2.5 Pressure Ratings

- .1 Unless otherwise indicated, use valves suitable for minimum 862 kPa (125 psig) WSP and 230 degrees C (450 degrees F).

2.6 Valve Operators

- .1 Provide suitable hand wheels for gate, globe or angle, radiation and drain valves, and inside hose bibbs.
- .2 Balance Valves any type: provide locking memory stop.
- .3 Provide one plug cock wrench for every plug cock valve.
- .4 Butterfly Valves HVAC service:
 - .1 200 mm and larger: Provide lever lock handle with toothed plate for shutoff service.
 - .2 Less than 200 mm: Provide 10 – position handle with memory stops for shutoff service.

2.7 Solenoid Control Valve - Natural Gas

- .1 CSA approved for pressure and service.
- .2 Bronze body, plug or ball valve.
- .3 Solenoid operator, voltage and power rating as required to interface with control system.
- .4 Refer to Section 20 90 00, Controls.

3. EXECUTION

3.1 Installation and Application

- .1 Install valves with stems upright or horizontal, not inverted, unless otherwise noted.
- .2 Install gate valves with stems horizontal or 45 degrees down from horizontal.
- .3 Use ball valves for gas service. Plug cocks are not to be used for gas isolation service.

3.2 Isolation Valves

- .1 Isolation valves are to be ball type valves, pipe size as required, but in no case less than 12 mm diameter.
- .2 For equipment removal purposes, isolation valves are to be installed with companion screwed unions on piping less than 75 mm diameter, or flanged connections on piping 75 mm and larger. Grooved mechanical couplings may be used for equipment removal, subject to accessibility, suitability and where approved by specification terms for that piping system or equipment.

-
- .3 Install valves as close as possible to isolated equipment in order to minimize the amount of water lost during maintenance, replacement or drain down operations.
 - .4 If the piping serving a piece of equipment will impede the removal of that equipment, ensure that isolation valve and union or flange placement allows the piping to be fully removed.
 - .5 Isolation drain valves are to be provided with combination air inlet fitting as required to relieve vacuum during draining operations.
 - .6 Install gate valves or ball valves where approved for shutoff and isolating service, or to isolate equipment, parts of systems or vertical risers.

3.3 Relief Valves

- .1 Test relief valve. Ensure that it reseats correctly without leaking and does not splash or cause flooding at discharge.
- .2 Pipe directly to drain, with discharge facing down into drain. Do not terminate horizontally or in any other configuration where discharge may splash out of drain.

3.4 Solenoid Control Valve - Natural Gas

- .1 Install in approved location, with space for service access.
- .2 Provide shut off valve upstream of the solenoid valve. Provide unions on both sides of solenoid valve for service and removal.

3.5 Pressure Regulating Valve - Natural Gas

- .1 Provide pressure reducing valves where shown or where required.
- .2 Locate the pressure regulating valve on the roof beyond the code required clearance from outdoor air intakes. Do not use piping to extend the vents along the roof or above the equipment served.

SECTION 20 20 15 – SEISMIC RESTRAINTS

1. GENERAL

1.1 Work Included

- .1 Seismic restraints for all mechanical systems.
- .2 Certification by a Professional Engineer.

1.2 General Requirements

- .1 All seismic restraining devices shall be supplied by an approved supplier with the exception of seismic restraining devices which are factory installed and are standard equipment with the machinery.
- .2 All submittals shall bear the seal and signature of a registered Professional Engineer.

1.3 Standards

- .1 Seismic restraint devices, accessories and methods shall meet the requirements of the British Columbia Building Code.

1.4 Submittals - Prior to Construction

- .1 Letters of Assurance: Submit Supporting Registered Professional Schedule S-B covering the mechanical systems, within the scope of this project, in their entirety. Schedules shall not be qualified or include any notes that would reduce the scope or responsibility.

1.5 Submittals - Prior to Substantial Performance

- .1 Letters of Assurance: Submit Supporting Registered Professional Schedule S-C covering the mechanical systems, within the scope of this project, in their entirety. Schedules shall not be qualified or include any notes that would reduce the scope or responsibility.

1.6 Review and Certification

- .1 Mechanical systems Seismic Engineer: Include for and pay the necessary fees for the services of a qualified Professional Engineer, registered in the province of British Columbia, to provide the necessary certifications required by the British Columbia Building Code, all local codes, and as herein specified.

2. PRODUCTS

2.1 Seismic Restraints

- .1 The restraints shall conform to the requirements of the mechanical systems Seismic Engineer.

3. EXECUTION

3.1 Application

- .1 It is the responsibility of the contractor to ensure that device sizing and application is correct for each individual system or piece of equipment.
- .2 Provide restraints on all new piping, tanks and equipment that are provided under the scope of the mechanical contract.

3.2 Review and Certification

- .1 The Seismic Engineer shall inspect all components of the completed seismic restraints installation.
- .2 Submit a sealed review declaring that the completed seismic installation is installed in accordance with the plans and specifications prepared by the Seismic Engineer.

- .3 Letters of Assurance: Submit Supporting Registered Professional Schedules S-B and S-C covering the mechanical systems in their entirety. Schedules shall not be qualified or include any notes that would reduce the scope or responsibility.

SECTION 20 40 00 – PLUMBING - GENERAL

1. GENERAL

1.1 Work Included

- .1 Cleanouts.
- .2 Roof drains.
- .3 Area drains.
- .4 Plumbing vents.
- .5 Trap primers

1.2 General Requirements

- .1 Provide materials, equipment and labour to install plumbing as required by Provincial and local codes as specified herein.
- .2 Provide water and drainage connections to equipment specified in other sections of this specification.

1.3 Quality Assurance

- .1 Provide new equipment, CSA approved.

1.4 Submittals - Prior to Construction

- .1 Roof Drains: Dimensions and installation details.
- .2 Floor drains: Accessories, dimensions and installation details.
- .3 Roof Drain Flashing: Provide samples and written acceptance by Master Sheet Metal and Roofing Contractors Association for non-metallic roof drain flashing.
- .4 Relief valves – Provide a test report with photographs confirming that each relief valve seats correctly without leaking and does not splash or cause flooding at the discharge.

2. PRODUCTS

2.1 Cleanouts and Cleanout Accessories

- .1 Sanitary: Provide caulked or threaded type cleanouts extended to unfinished floor or wall surface.
- .2 Storm: Provide bolted cover plate or threaded cleanouts on vertical rainwater leaders.
- .3 Floor cleanout access covers in unfinished areas shall be round with nickel bronze scoriated frames and plates. Wall cleanouts shall be located behind approved access panels.

2.2 Waterproofing Membranes – Non-metallic

- .1 Provide flexible, non-plasticized multiply chlorinated polyethylene. Provide internally reinforced sheet for applications where the sheet will be exposed, subject to outdoor or extreme temperatures or where specified.

2.3 Area Drain AD-1 Parking Garage

- .1 Epoxy coated, fabricated steel body, large sump, integral anchor flange and frame, extra heavy-duty cast-iron grate, side outlet, solids retaining baffle with weep holes, secure grate fastening. DIN Load Class D, Extra Heavy Duty.

2.4 Clean out to Grade

- .1 Landscaped surface: PVC or ABS threaded top, male or female wrench fitting.
- .2 Concrete or paved surface: Brass, PVC or ABS threaded top, female wrench fitting, flush with finished surface.

2.5 Trap Primers

- .1 Electronic timed trap primers shall be complete with internal air gap, manifold, 120V controller, solenoid valve and enclosure. Equal to Precision Plumbing Products Mini-Prime or Precision Plumbing Products Prime-Time.

3. EXECUTION

3.1 Installation

- .1 Install gas piping in open or ventilated spaces. Pitch lines and provide drip legs for condensation collection points. Where gas piping is run in a concealed space, provide ventilation grilles as required.
- .2 Each trap primer should serve only one piece of equipment. Install trap primers:
 - .1 Where required by Codes
 - .2 Area Drains not subject to freezing
 - .3 Other locations where indicated.
- .3 Drainage lines shall grade 2% grade unless otherwise shown on drawings.
- .4 Underground drainage lines shall be sized at 75 mm minimum unless otherwise noted.
- .5 Install pressure reducing valves to limit maximum static pressure at plumbing fixtures to 550 kPa (80 psi).
- .6 Install sanitary wye or double wye fittings on all drainage systems. Tee or double tee fittings are not permitted.
- .7 Several sections of drainage piping positioned under new floor concrete slabs must be installed prior to final compaction operations. Generally, any piping systems deeper than 600 mm below the finished floor elevation must be installed before compaction. Drain and vent stacks must be extended above the finished grade elevation and secured to allow compaction operations to proceed around these extensions.

3.2 Cleanouts and Access Covers

- .1 Unless otherwise noted, floor cleanouts in finished areas are not approved.
- .2 Ensure ample clearance at cleanout for rodding of drainage systems.
- .3 Provide cleanouts on all drainage systems where piping leaves the crawlspace.
- .4 Provide cleanouts at the base of each stack.

3.3 Roof Drains and Overflow Drains

- .1 Provide horizontal offset on rainwater leader, 1.0 m long minimum, complete with flexible joint (mechanical joint or grooved) to allow for movement of roof and/or rainwater leader.
- .2 Provide approved sheet lead connection between drain and stack. O-ring type expansion joints are not approved.
- .3 Set overflow drains in position and adjust so that overflow lip is 100 mm above roof drain lip. If the overflow drain cannot be positioned on sloped roof 100 mm above RD-1, then provide a weir extension, soldered into the body, height adjusted to suit the 100 mm raised lip requirement for overflow drain. Fill in the conical shaped cavity created by the weir extension with waterproof cementitious material.

3.4 Vents and Pipe Penetrating Roof

- .1 Vent, gas and refrigerant pipes shall project through the roof and shall be provided with specified roof jack and flashing flange. Flashing shall be extended 300 mm clear on all sides of projecting pipe.
- .2 Provide standard flashing caps as specified.

- .3 Vents specified or provided with vandal resistant, close slotted vent caps shall not be sized less than 50 mm.
- .4 Refer to Section 20 00 90, Supports and Anchors.

3.5 Floor Drains

- .1 Connect to trap primer.
- .2 Set drain at elevation to allow finished floor to slope to mouth. Coordinate setting elevation with floor finish thickness.
- .3 Provide flashing of sheet lead or approved non-metallic membrane where floor drains are located over occupied spaces.

3.6 Trap Primers

- .1 Each manifold connection shall serve no more than one trap.

3.7 Service Connections

- .1 Before commencing work, check invert elevations required for sewer connections. Confirm inverts and ensure that these can be properly connected with sufficient slope for drainage.
- .2 Connect to existing sanitary and storm sewer services as shown on site services drawings.

3.8 Clean Out to Grade

- .1 Provide a cleanout to grade on all drain piping leaving the building, outside the building within 1,500 mm of the building wall.
- .2 Grass surface: Set pipe flush with grass surface and install cap.
- .3 Planted surface: Extend pipe 100 mm above garden surface install cap.
- .4 Concrete or paved surface: Set pipe flush with paved surface and install cap in a manner than does not create a tripping hazard, cleaning or snow clearing impediment.
- .5 Refer to detail.

3.9 Interceptors

- .1 Install interceptor in a manner that allows removal of covers and adequate access for service. Position device to allow removal of screens and strainers, and to facilitate maintenance and cleaning.
- .2 Align inlet, outlet and vent with drainage system elevations.
- .3 Provide suspension system as required.
- .4 Coordinate position of recess in floor.
- .5 Coordinate millwork modifications required.

SECTION 20 50 10 – FIRE EXTINGUISHERS

1. GENERAL

1.1 Description of Work

- .1 The following specification is to be read in conjunction with the mechanical drawings.
- .2 Supply and install fire extinguishers and cabinets in accordance with NFPA-10, mechanical drawings, specifications, and manufacturer’s recommendations.
- .3 Coordinate the installation with the architectural drawings, and other building trades, notify the engineer of any conflicts or deviations to the approved plans.

1.2 Work Included

- .1 Devices listed includes all accessories required for device to meet intended function:

	Products	Acceptable Manufacturers & Reference Models*	Shop Drawings & Installation Instructions**	Other Submittals	Applicable Codes & Standards
1.	Fire Extinguisher – Dry Chemical	Amerex Ansel Badger Flag Strike First Wilson & Cousins	Required		ULC

* Refer to General Mechanical Provisions Section for requirements regarding Acceptable Manufacturers and Agencies.

** Refer to General Mechanical Provisions Section for requirements regarding submittal of Shop Drawings and Installation Instructions.

1.4 Quality Assurance

- .1 Codes, Bylaws Standards and Approval. Installation, products, workmanship, and testing shall conform to the currently referenced edition of the following:
 - .1 BC Building Code.
 - .2 BC Fire Code.
 - .3 National Fire Protection Association NFPA-10 – Standard for portable fire extinguishers.
 - .4 Local Municipal Bylaws.
 - .5 Fire commissioner of Canada Standards.
 - .6 Where discrepancies occur between a code, standard or these specifications, the most stringent shall apply.
- .2 Installation shall be subjected to design approval, inspection and testing of the Authority having Jurisdiction.
- .3 System components shall be ULC / cUL Listed and FM Approved for portable fire extinguisher use. Installation shall comply with the individual system component’s specific listing or approval.
- .4 All system components shall be installed in accordance with the manufacturer’s recommended installation instructions.

1.5 Design Criteria

- .1 Classification of occupancies and commodities shall comply with NFPA-10.

2. PRODUCTS

2.1 Fire Extinguisher – Dry Chemical

- .1 UL listed for class A, B and C fires, dry chemical ammonium phosphate powder, red finish, complete with mounting bracket.
- .2 Type 2 – 4.6 kg (10 pound), rating 6A/80BC.

3. EXECUTION

3.1 Installation

- .1 Fire extinguishers are to be installed with mounting brackets where no cabinet type is identified.
- .2 Mount extinguishers and cabinets such that the top of the extinguishers is 1.0 m (3.3') from the floor for extinguishers 9.2 kg (20lb) or greater.
- .3 Mount extinguishers and cabinets such that the top of the extinguishers is 1.5 m (5') from the floor for extinguishers less than 9.2 kg (20lb).

3.2 Identification

- .1 Identify fire extinguishers in accordance with NFPA-10.
- .2 Attach service tag to fire extinguishers, indication month and year of installation, with space for recording subsequent service dates.

SECTION 20 80 19 – GAS FIRED UNIT HEATERS

1. GENERAL

1.1 Work Included

- .1 Gas fired unit heaters.
- .2 Venting.
- .3 Accessories.

1.2 Quality Assurance

- .1 Conform to requirements of CSA, Provincial and Municipal Codes and be CSA listed.

1.3 Submittals - Prior to Construction

- .1 Provide complete shop drawings including equipment components, control devices, and control schematics.
- .2 Shop drawings shall be endorsed by equipment manufacturer.

1.4 Submittals - Prior to Substantial Performance

- .1 Manufacturer's start up report.

1.5 Approved Manufacturers

- .1 Manufacturers whose products are approved in principle but subject to requirements of drawings and specifications are:
- .2 Flame Master, Hastings, Inter-City, Lennox, ITT Grinnell, Olsen, Reznor, Trane.

2. PRODUCTS

2.1 Type

- .1 Provide horizontal type with natural gas burner and automatic electric interrupted pilot ignition.
- .2 Provide self-contained, packaged, factory assembled, pre-wired unit consisting of cabinet, fan, heat exchanger, burner, controls and thermostat.

2.2 Construction

- .1 Cabinet: Heavy gauge galvanized steel with baked enamel finish, easily removed and secured access doors, glass fibre insulation and reflective liner.
- .2 Heat Exchanger: Aluminized steel of welded construction.
- .3 Supply Fan: Forward curved fan type, rubber mounted with direct drive 1750 rpm motor.

2.3 Burner

- .1 Gas Burner: Atmospheric type with adjustable combustion air supply, equipped with combination gas valve and pressure regulator incorporation manual shut-off, pilot valve, automatic 100% shut off and thermocouple pilot safety device.
- .2 Gas Burner Safety Controls: Thermocouple sensor prevents opening of solenoid gas valve until pilot flame is proven and stops gas flow on ignition failure. Provide automatic spark ignited pilot systems with pre-purge and post-purge switches, 100% shut off and pressure differential switch.

2.4 Controls

- .1 Low voltage, adjustable two stage thermostat, controls, fan and burner operation in sequence to maintain room temperature setting.

- .2 High limit control, with fixed stop at maximum permissible setting, de-energizes burner on excessive bonnet temperature and energizes burner when temperature drops to lower safe value.
- .3 Provide manual (summer/winter) switch for continuous fan operation.

2.5 Draft Control

- .1 Provide unit with galvanized steel flue pipe having airtight joints, connected to built-in draft diverter.

2.6 Nozzle/Louvres

- .1 Provide 30-degree downturn nozzle complete with standard horizontal and vertical louvres.

3. EXECUTION

3.1 General

- .1 Do not operate systems for any purpose except testing until all required approvals are in place.
- .2 Install equipment as directed by the manufacturer.
- .3 Suspend equipment from structure.
- .4 Refer to schedules for performance.

SECTION 20 80 20 – FANS

1. GENERAL

1.1 Work Included

- .1 Centrifugal fans.
- .2 Ceiling circulation fans.
- .3 Fan accessories.

1.2 Quality Assurance

- .1 Conform to AMCA Bulletins regarding construction and testing. Fans shall bear AMCA certified rating seal.
- .2 Equipment shall meet the requirements of:
 - .1 British Columbia Building Code.
 - .2 Canadian Standards Association.
 - .3 Underwriters Laboratories Canada.
 - .4 All other local codes and requirements.
- .3 Polyphase, squirrel cage, single speed NEMA/EEMAC Design A or B induction motors, between 746 watts (1 hp) and 149.2 kw (200 hp), whether in packaged equipment or not, shall comply with the current requirements of the British Columbia Energy Efficiency Standards Regulation, and specifically, CSA C390-93 Energy Efficiency Test Methods for Three Phase Induction Motors.

1.3 Submittals - Prior to Construction

- .1 Shop drawings must be submitted and reviewed by the Engineer prior to the contractor ordering or shipping any subject equipment. Payments will not be processed for equipment not properly documented and reviewed under the terms of submittal.
- .2 Submit certified shop drawings for the following:
 - .1 Fan curves and sound data, with fan and system operating point plotted on curves.
 - .2 Calculations and technical data to support drive selection.
 - .3 Fan details, isolation and details.
 - .4 Cabinet construction, gauge, access doors, fasteners.
 - .5 Power wiring diagrams and electrical characteristics.
 - .6 Control wiring diagrams and interfacing details.
 - .7 Maintenance requirements.

1.4 Acceptable Manufacturers

- .1 Manufacturers of ceiling propeller fans whose products are approved in principle, but subject to requirements of drawings and specifications are:
 - .1 Banvill, CanArm, Big Ass Fans.

2. PRODUCTS

2.1 General

- .1 Statically and dynamically balance fans so no objectionable vibration or noise is transmitted to occupied areas of the building.
- .2 Provide balanced variable sheaves for motors 11 kw (15 hp) and under, and fixed sheaves for over 15 kw.

- .3 Fans shall be capable of accommodating static pressure variations of +10% with no objectionable operating characteristics.
- .4 Unless otherwise noted, include all motors and drive combinations with electrical characteristics as detailed elsewhere.
- .5 Fan hubs and sheaves shall be keyed to shafts for fans over 0.56 kw (3/4 HP). Use of flat ground surface and set screws are not approved.
- .6 Select variable and adjustable pitch sheaves unless otherwise specified, so that required rpm is obtained with sheaves set at mid-position, and approximate speed adjustment of 25%.
- .7 Rate drive as recommended by manufacturer, but minimum 1.5 times power rating of the motor. This minimum power rating shall apply through the full range of adjustable sheave sizes. Submit calculations and technical data with shop drawings, to support drive selection.
- .8 Bearings shall have grease connections. All extended grease lines shall be factory pre-charged.
- .9 Where Variable Speed Drives are used, motors shall be inverter ready and shall include shaft grounding.
- .10 Provide all necessary specialized tools and equipment required to perform speed adjustments on ECM, PSC or other motor types.

2.2 Nederman Vehicle Exhaust Fans

- .1 Refer to schedules for fan details and accessories. Refer to Cash allowance CA-2.

2.3 Circulating Fans – Ceiling Mounted

- .1 Provide three or four blade, metal ceiling mounted air circulation fans.
- .2 Provide variable speed motor and controller for each fan.
- .3 Provide welded wire guard, 10-gauge wire, complete with mounting accessories.
- .4 Mounting base shall be secure and adjustable to provide proper hang angle and to withstand swaying forces.

2.4 Controls

- .1 Nederman MagnaRail: Radio Transmitter for automatic start/stop.
- .2 Circulating Fans – Ceiling Mounted: Start/Stop wall switch: Fan motors as specified in this Section. Switches are specified in the Electrical specifications.

3. EXECUTION

3.1 Installation

- .1 Where inlet or outlet is exposed, provide safety screen.
- .2 Supply and install sheaves as necessary for final air balancing.
- .3 Provide Local Control and other switches or motor controls noted on Division 20 schedules or in other Division 20 sections for installation by other trades.

3.2 Startup.

- .1 Start units with properly trained personnel and provide documentation of testing that complies with manufacturer's IOM start-up instructions.
 - .1 In the event that initial start-up of the unit fails due to component or construction failure, manufacturer shall be responsible for all labour and materials for corrective action to achieve proper start-up.
 - .2 If the unit fan section uses a belt drive system, complete "Alignment Report for Belt Drives". See Section 20 00 41 – Equipment Startup for details.

-
- .3 If the unit fan section uses a belt drive system, complete “Re-Tension Report for Belt Drives” immediately prior to takeover of the equipment by the Owner. See Section 20 00 41 – Equipment Startup for details.

3.3 Performance

- .1 Refer to schedules.

SECTION 20 80 40 – DUCTWORK

1. GENERAL

1.1 Work Included

- .1 Ductwork and plenums.
- .2 Fasteners.
- .3 Sealants.
- .4 Flexible ducts

1.2 Definitions

- .1 Duct sizes are inside clear dimensions. For acoustically lined or internally insulated ducts, maintain sizes inside ducts.
- .2 Medium Pressure: Static pressure in ducts less than 1.50 kPa (6" wg) and velocities greater than 10 m/s (2,000 fpm).

1.3 Quality Assurance

- .1 Ductwork and methods shall meet the requirements of:
 - .1 British Columbia Building Code.
 - .2 NFPA 90A Air Conditioning and Ventilation Systems.
 - .3 All other local codes and requirements.
- .2 Fabricate in accordance with ASHRAE and SMACNA manuals.

1.4 Job Conditions

- .1 Store ductwork on site or in warehouse in dry, heated locations. Cover all opening ductwork with polyethylene sheets and seal with tape.

1.5 Submittals - Prior to Construction

- .1 Submit duct corrosion resistant coating. Include list of chemicals to which the coating is resistant.
- .2 Flexible duct: Technical information on materials, flame resistance, construction, duty temperature. Provide a sample if requested.

1.6 Acceptable Manufacturers

- .1 Manufacturers of flexible exhaust connection ducts whose products are approved in principle, but subject to requirements of drawings and specifications are:
 - .1 Nederman or equivalent.

2. PRODUCTS

2.1 Materials

- .1 Ducts: Galvanized steel lock forming quality, having galvanized coating of 0.38 kg/m² on both sides.
- .2 Fasteners: Use sheet metal screws, rivets and bolts.
- .3 Sealant: Water resistant, fire resistive, compatible with mating materials.

2.2 Flexible Ducts

- .1 General HVAC Supply and Return: Corrugated aluminum or fabric supported by helically wound steel wire or flat steel strips wrapped with 25 mm thick flexible fibrous glass insulation, enclosed by seamless plastic vapour barrier jacket.

3. EXECUTION

3.1 Fabrication

- .1 Unless otherwise indicated, branch ductwork serving a single diffuser or grille shall be sized equal to the nominal grille size or the diffuser neck size.
- .2 Complete metal ducts within themselves with no single partition between ducts. Where width of duct exceeds 300 mm, cross break for rigidity. Open corners are not acceptable.
- .3 Lap metal ducts in the direction of air flow. Ensure the interior is smooth.
- .4 Construct tees, bends and elbows with radius of not less than 1.5 times the width of the duct on centre line. Where this is not possible, and where rectangular elbows are used, provide approved type of air foil turning vanes. Where acoustical lining is provided, provide turning vanes of perforated metal type.
- .5 Increase duct sizes gradually, not exceeding 15 degrees divergence.
- .6 Rigidly construct metal ducts with joints mechanically tight, substantially airtight, braced and stiffened so as not to breathe, rattle, vibrate or sag.
- .7 Ducts subject to noise transfer or vibration are to be reinforced to prevent duct vibration and sound transmission. Provide cold rolled steel angle bar, not sheet metal break angle, bolted or riveted to the duct in parallel or cross fashion to completely eliminate duct vibrations and sound transmissions.
- .8 Provide easements where low pressure ductwork conflicts with piping or structure, with easements not exceeding 10% of the duct area. Where easements are not required, split ductwork into two ducts maintaining original duct area.
- .9 Provide necessary baffling in mixed air plenums to ensure good mixed air temperature with variations of not more than plus or minus 3°C under all operating conditions.

3.2 Installation

- .1 Provide openings in ductwork where required to accommodate thermometers and controllers. Provide pitot tube openings where required for testing of systems, complete with metal can and spring device or screw to ensure against air leakage. Where openings are provided in insulated ductwork, install insulation material inside a metal ring. Provide sealing grommet flush plug for holes.
- .2 Ductwork shall be protected from damage by other trades. Provide plywood covering or reinforce as required where ductwork is installed at low level in what could be considered an access path.
- .3 Locate ducts with sufficient space around equipment to allow normal operating and maintenance activities.
- .4 Ducts shall be sealed with approved sealant. Sealant shall be applied to all joints and connections of all descriptions in such a manner that no air may enter or leave the ductwork through a joint or connection. The engineer must be satisfied that no joint or connection will leak. If necessary, the ductwork shall be pressurized with the specified equipment to demonstrate that there are no leaks. Tape seal only joints are not approved.
- .5 In concealed spaces where conditions will not permit metal ducts, diffusers or troffer boots may be connected to low pressure ducts with flexible duct maximum length 1,000 mm. Hold in place with strap or clamp.
- .6 At each point where ducts pass through partitions, seal joints around duct with non-combustible material.

3.3 Flexible Ducts

- .1 General HVAC Supply and Return: Length shall be a maximum of 1.5 times the duct diameter, with maximum 15° offset from duct axis. Do not use flexible ductwork in place of elbows. Support as necessary to prevent sagging. Fasten at each end with plastic strapping and a minimum of three screws.
- .2 Do not install flexible ductwork on exposed ductwork.

3.4 Duct Gauges - General

- .1 Rectangular Ducts

Maximum Width	gauge
.1 Up to 12 inches	26
.2 13 inches to 30 inches	24
.3 31 inches to 55 inches	22
.4 56 inches and over	20
- .2 Spiral Round Ducts, Maximum 2.0 in wg positive

Maximum Diameter	gauge
.1 Up to 14 inches	28
.2 15 inches to 25 inches	26
.3 26 inches to 36 inches	24
.4 37 inches to 50 inches	22
.5 51 inches to 60 inches	20
.6 61 inches and over	18
- .3 Spiral Round Ducts, Maximum 2.0 in wg negative

Maximum Diameter	gauge
.1 Up to 8 inches	28
.2 9 inches to 14 inches	26
.3 15 inches to 25 inches	24
.4 26 inches to 36 inches	22
.5 37 inches to 50 inches	20
.6 51 inches to 60 inches	18
.7 61 inches and over	16

SECTION 20 80 70 – AIR OUTLETS

1. GENERAL

1.1 Work Included

- .1 Outside louvres.

1.2 Quality Assurance

- .1 Air flow tests and sound level measurement shall be made in accordance with applicable Air Diffusion Council equipment test codes and ASHRAE Standards.
- .2 Unit ratings shall be approved by the Air Diffusion Council.
- .3 Manufacturers shall certify catalogued performance and ensure correct application of air outlet types.

1.3 Job Conditions

- .1 Review the requirements of outlets as to size, finish and type of mounting prior to submitting shop drawings and schedules of outlets.
- .2 Positions indicated are approximate only. Check locations of outlets and make necessary adjustments in position to conform with Architectural features, symmetry and lighting arrangement.

1.4 Submittals - Prior to Construction

- .1 Physical: For each type of air outlet, louvre, grille, register etc., submit manufacturer certified data on dimensions, mounting method, accessories, dampers, materials, finish, etc.
- .2 Performance: For each type of air outlet, louvre, grille, register etc., submit manufacturer certified data on air flow, sound, pressure loss, velocity.
- .3 Colour chips and samples for powder coated louvres, outlets, fittings and accessories.

2. PRODUCTS

2.1 General

- .1 Base air outlet application on maximum space noise level of NC 25.
- .2 Provide baffles to direct air away from walls, columns or other obstructions within the radius of diffuser operation.

2.2 Outside Louvres General

- .1 Louvres shall be material, thickness, frame type, and configuration specified on schedule.
- .2 Bird screen: Galvanized mesh, 20 gauge minimum, welded, 13 mm square mesh.
- .3 If specified, inlet louvres shall be rainproof with flow interrupter to trap moisture and prevent ingestion into the duct system.
- .4 If specified, exhaust, discharge or relief louvres shall be fitted with fully counter balanced back draft dampers. Refer to Section 20 80 60.

2.3 Louvres Type L

- .1 Extruded aluminum with flange, welded assembly.
- .2 Bird screen: Galvanized mesh, 20 gauge minimum, welded, 13 mm square mesh.
- .3 If noted, exhaust, discharge or relief louvres shall be fitted with fully counter balanced back draft dampers, unless otherwise noted. Refer to Section 20 80 60.
- .4 Free area minimum 50%. Zero water penetration until free area velocity exceeds 6.25 m/s (1233 fpm).

- .5 Colour: Refer to Schedules.
- .6 Equal to Price DE635

3. EXECUTION

3.1 General

- .1 Paint ductwork visible behind air outlets, flat black.
- .2 Provide fire rated material, either blanket or rigid board, with rating equal to ceiling or wall system, behind outlets piercing fire rated membranes.
- .3 Size air outlets as indicated on drawings.
- .4 Refer to air outlet schedule for requirements.

3.2 Balancing Dampers

- .1 Provide a butterfly balancing damper on each branch duct leading to air supply outlets or inlets. This is in addition to a grille mounted balancing damper if such a device is specified. The branch mounted supply damper is to be within 3 metres of the outlet, but no closer than 1 metre, measured along the duct run. If the required location is behind an inaccessible ceiling or wall, adjust the location to allow easy access, or provide an acceptable access door, after review with the Engineer.

3.3 Louvres or Grilles

- .1 Outside dimensions of frames shall be coordinated with structural and framing shop drawings.
- .2 Mount and secure louvres in weatherproof frames, seal with approved coloured silicone based flexible sealant.
- .3 Provide specified bird and insect screen on inlet, exhaust grilles or louvres.
- .4 Exhaust, discharge or relief louvres shall be fitted with fully counter balanced back draft dampers, unless otherwise noted.