



**Subdivision and Development Servicing Bylaw  
No. 4293**

# Subdivision and Development Servicing Bylaw No. 4293

## **CITY OF** **SALMON ARM**

Bylaw 4293

Schedule A – Map

Schedule B – Design Manual

Part 1 - Servicing Standards

Part 2 - Specification Drawings

Part 3 - Construction Specifications

Schedule C – Forms

Schedule D – Approved Materials List

# CITY OF SALMON ARM

## BYLAW NO. 4293

### A Bylaw to Require Works and Services in Connection with the Subdivision and Development of Land

---

WHEREAS Section 506 of the Local Government Act empowers the Council to enact a bylaw to regulate and require the provision of works and services in respect of the subdivision of land, to require the connection of water, sewer and drainage systems to City systems in accordance with bylaw standards, to require parcels of land not connected to City water systems to have a potable water source of a specified capacity, and to require the construction of on-site and off-site works as a condition of the approval of a subdivision or the issue of a building permit;

AND WHEREAS Section 507 of the Local Government Act empowers the Council to require an owner of land being subdivided or developed to provide excess or extended services as defined in that Section;

NOW THEREFORE, the Council of the City of Salmon Arm, in open meeting assembled, enacts as follows:

#### 1.0 GENERAL

##### 1.1 TITLE

This bylaw may be cited for all purposes as "City of Salmon Arm Subdivision and Development Servicing Bylaw No. 4293."

##### 1.2 DEVELOPMENT AREAS

In this bylaw, a reference to a Development Area is a reference to an area designated on Schedule A to the bylaw.

##### 1.3 INTERPRETATION

In this bylaw, unless the context otherwise requires:

**"Approving Officer"** means the person appointed by Council as *Approving Officer* under Section 77 of the Land Title Act, and includes a *Deputy Approving Officer*.

**"Arterial Street"** means a *Street* designated as an *Arterial Street* in the City of Salmon Arm *Official Community Plan*.

**"Boulevard"** means the area between a *Parcel Line* and the traveled portion of a *Street* or *Highway*, excluding curb and gutter and sidewalks.

**"Building"** means any *Structure* used or intended for supporting or sheltering any use or occupancy.

**"Building Official"** means the person or persons designated by the City of Salmon Arm as Building Inspectors, Plumbing Inspectors or Plan Checkers, and includes supervisors for these positions.

**"City"** means the City of Salmon Arm.

**"City Engineer"** means a person designated by the City of Salmon Arm as the *City Engineer* or duly authorized representative.

**"Council"** means the duly elected *Council* of the City of Salmon Arm.

**"Collector Street"** means a *Street* designated as a *Collector Street* in the City of Salmon Arm *Official Community Plan*.

**"Contractor"** means the *Owner/Developer* or the person appointed by the *Owner/Developer* to construct the *Works and Services* required by this bylaw.

**"Cul-de-sac"** means a *Street* that does not permit through traffic, with a turn-around at the end.

**"Development"** means the alteration of land by the construction, installation, extension or alteration of any *Building* or *Structure* which requires a *Building Permit*.

**"Director of Development Services"** means a person designated by the City of Salmon Arm as the *Director of Development Services* or a duly authorized representative.

**"Final Approval"** means endorsement of a *Subdivision* plan by the *Approving Officer* in accordance with the Land Title Act or Strata Property Act.

**"Frontage"** means the boundary of a *Parcel* abutting a *Street*.

**"Highway"** includes a *Street*, road, *Lane*, walkway, trail, bridge, viaduct and any other way open to public use, but does not include a private right-of-way on private property.

**"Lane"** means a public way 10.0 metres (32.8 ft.) or less in width but more than 4.5 metres (14.7 ft.) in width.

**"Low Density Residential Development"** means any residential *Building* conforming to the *Official Community Plan* designation of Low Density, or any *Single Family Dwelling* including a detached or attached secondary suite.

**"Multi-family"** means any residential *Building* consisting of three or more dwelling units.

**"Official Community Plan"** means a community plan that is adopted by the *Council* of the City of Salmon Arm pursuant to Part 14, Division 4 of the Local Government Act.

**"Owner/Developer"** means a person or persons registered in the Land Title Office as the *Owner* of a *Parcel*.

**"Parcel"** means a lot, block, bare land strata lot, or other area in which land is held or into which it is subdivided, but does not include a *Highway*.

**"Parcel Line"** means a line dividing one *Parcel* from another *Parcel*; or from a *Highway*; or from a natural body of water.

**“Parcel Line Adjustment”** means a change in boundaries between two or more *Parcels* that does not create additional *Parcels* but shall not include a *Parcel Line Adjustment* where one of the *Parcels* is divided by a *Highway*, Canadian Pacific Railway *Parcel* or right-of-way or natural body of water and as a result of the boundary adjustment the portion divided by the *Highway*, Canadian Pacific Railway *Parcel* or right-of-way or natural body of water is created as a separate *Parcel*.

**“Professional Engineer”** means a person registered or licensed as such under the provisions of the Engineers and Geoscientists Act of B.C.

**“Single Family Dwelling”** means any *Building* consisting of one dwelling unit as defined in Zoning Bylaw No. 2303, as amended.

**“Street”** includes a *Highway*, road or *Cul-de-sac*, but excludes a *Lane*, trail, path, walkway, bridge, viaduct or any private access or private roadway and includes a frontage road that is adjacent to a Controlled Access *Highway*.

**“Subdivision”** means the division of land into two or more *Parcels* and includes a *Subdivision* under the Strata Property Act.

**“Subdivision Potential”** means the property may be considered for *Subdivision* under the current zoning.

**“Structure”** means any construction fixed to, supported by or sunk into land or water, including swimming pools, satellite dishes, parkades, and retaining walls, but does not include concrete, asphalt, brick or tile surfaced areas.

**“Works and Services”** means any public facility or utility which is required by this bylaw and without restricting the generality of the foregoing includes: the supply and distribution of water, including fire hydrants; the collection and disposal of sewage; the collection and disposal of storm/drainage water; ditching; street lighting; dedicated and constructed *Highways*, including asphalt or concrete pavement surface, curb & gutter, sidewalks, trails, fences, *Boulevards*, pavement markings, traffic signals, signage, park benches, street trees, and planters, and the supply and distribution of electrical power.

2.0 ADMINISTRATION

- 2.1 The purpose of this bylaw is to require and regulate the provision of *Works and Services* in respect of the *Subdivision* and *Development* of land within the *City*.
- 2.2 As a condition of the approval of a *Subdivision* or the issuance of a Building Permit, the *Owner/Developer* of the land shall provide *Works and Services* in accordance with the standards prescribed in this bylaw and shall pay all related administration and inspection fees in accordance with the City of Salmon Arm Fee for Services Bylaw.
- 2.3 The *Council* delegates to the *Approving Officer* the authority to prescribe all forms of agreement and other documents required in the administration of this bylaw, to execute all such agreements and all covenants, statutory rights of way, park land dedication agreements and other instruments connected with the *Subdivision* or *Development* of land.
- 2.4 The *Council* delegates to the *City Engineer* the authority to maintain an approved products list for the purposes of this bylaw.
- 2.5 Unless otherwise defined herein, all words or expressions in this bylaw shall have the same meaning as like words or expressions contained in the Land Title Act, Local Government Act or Interpretation Act.
- 2.6 If any part, section, sub-section, clause, or sub-clause of this bylaw for any reason is held to be invalid by the decision of a Court of competent jurisdiction, the invalid portion shall be severed and the decision that it is invalid shall not affect the validity of the remaining portions of this bylaw.

### 3.0 DESIGN REQUIREMENTS

The *Owner/Developer* shall design and construct at their expense:

- 3.1.1 All onsite *Works and Services* specified in Table 1; and,
- 3.1.2 Except as otherwise provided in Section 5.0 of this bylaw, all offsite *Works and Services* specified in Table 1 on that portion of a *Highway(s)* immediately adjacent to the site, up to the centre line of that adjacent *Highway(s)*, as their requirement is directly attributable to the *Development*.

The determination of which *Works and Services* are required shall have regard for:

- (i) a need for increased flow or capacity of the service(s); or
- (ii) a need to upgrade the service(s) due to safety concerns, including but not limited to concerns regarding integration with existing services, created by the *Subdivision* or *Development* permitted by the Building Permit.

3.2 The City Engineer may require an *Owner/Developer* to design and construct *Works and Services* that are excess or extended services as defined in Section 507 of the *Local Government Act*, and for the purposes of Section 508 of the *Local Government Act* may:

- 3.2.1 Determine the proportion of the cost that relates to the excess or extended nature of the services;
- 3.2.2 Determine what parcels of land will be served by the services;
- 3.2.3 Determine what part of the cost is associated with service to each of the benefiting parcels;
- 3.2.4 Determine the amount of a latecomer charge to be imposed in respect of each of the benefiting parcels;
- 3.2.5 Execute on behalf of the *City* a latecomer agreement in respect of the services, and prescribe a form for such agreements; and
- 3.2.6 Levy latecomer charges in accordance with such agreements including simple interest at the rate of Prime Interest Rate plus two percent (2.0%), as established by the financial institution with which the *City* deals, calculated annually, and pay such charges and interest to the *Owner/Developer* in accordance with the terms of the relevant agreement.

3.3 Where this bylaw requires that the *Owner/Developer* construct excess or extended services as defined by Section 507 of the *Local Government Act* or the City Engineer requires excess or extended services under Section 3.2 of this bylaw, Council may deem the costs of these *Works and Services* to be excessive. In such a case, the costs shall be the responsibility of the *Owner/Developer* and the *Owner/Developer* may enter into a latecomer agreement in accordance with Section 508 of the *Local Government Act*, in the

form prescribed for that purpose by the *City Engineer*. Where the *City* agrees to cost share a portion or all of the excess or extended services, then the latecomer agreement shall include cost sharing provisions.

- 3.4 All *Works and Services* required for *Subdivision* or *Development* shall be constructed, at a minimum, to the specifications set out in Schedule B unless a change in the Design Criteria or Technical Specifications is required for engineering reasons and has been approved in writing by the *City Engineer*, and such a change does not alter the service level prescribed by this bylaw. Compliance with the specifications shall be certified on engineering drawings by a *Professional Engineer*.
- 3.5 Every *Parcel* created by *Subdivision* shall have not less than one *Frontage* on a *Street* and the *Street* or *Streets* shall be constructed to the standards and specifications set out in Schedule B.
- 3.6 Every *Street* in a *Subdivision* shall be constructed to the standards and specifications set out in Schedule B, according to the level of service described in Section 4 and 5 of this bylaw.
- 3.7 The minimum *Parcel Frontage* shall be not less than ten percent (10%) of the perimeter of the *Parcel*, except where lesser *Frontage* is approved by the *Approving Officer*.
- 3.8 Panhandle *Parcels* shall not be created by *Subdivision* unless:
- 3.8.1 The *Parcel* has no further *Subdivision Potential* or, where the *Parcel* has further *Subdivision Potential*, the panhandle access is located such that as future *Subdivision* occurs it may be dedicated and constructed as a *Street*;
- 3.8.2 The *Parcel* contains the required minimum *Parcel* area as specified in the Zoning Bylaw, exclusive of the panhandle; and
- 3.8.3 The width of the panhandle is at least:
- 6.0 metres where the *Parcel* has no further *Subdivision Potential*;
- 20.0 metres where the *Parcel* has further *Subdivision Potential*; or,
- 8.0 metres where a covenant is placed on title limiting the *Development* to a strata *Subdivision* in a form acceptable to the *Approving Officer* and the *Director of Development Services*.
- 3.9 Statutory rights-of-way shall be provided at time of *Subdivision* where water, sewer or drainage works required by this bylaw are not located in dedicated highways, and statutory right of way areas shall be of the following minimum widths:

# of Utilities in Corridor	Width of Utility Right-of-Way
One (1) - Utility	6.0m
Two (2) - Utilities	6.5m
Three (3) - Utilities	7.0m

Statutory rights-of-way widths may be increased as determined by the *City Engineer* to satisfy slope and access requirements, size and depth of utility.



#### 4.0 SERVICING REQUIREMENTS

- 4.1 All *Works and Services* required to be designed, constructed and installed at the expense of the *Owner/Developer* shall be designed, constructed and installed to the standards prescribed in this bylaw before the *Approving Officer* approves the *Subdivision* or the *Building Official* issues the Building Permit unless the *Owner*:
- a) deposits with the *City* a cash deposit, or an irrevocable Letter of Credit in a form and from a financial institution, acceptable to the *City*, in the amount of 125% of the construction cost, as estimated by the *Owner/Developer's Professional Engineer* and accepted by the *City Engineer*, for installing and paying for all *Works and Services* required under the bylaw; and
  - b) Enters into a Servicing Agreement with the *City* in the form prescribed for that purpose by the *City Engineer*, to construct and install the required *Works and Services* by a specified date or forfeit to the *City* the Security Deposit.
- 4.2 Where the *Works and Services* required under this bylaw cannot, in the opinion of the *City Engineer*, be constructed in accordance with sound civil engineering principles due to the limited scale of the project, the time of the year in which they would be constructed or any other technical reason, then the requirement may be fulfilled by the payment of cash equal to 100% of the amount estimated by the *City* as the cost of the required *Works and Services*. This cash payment may be used by the *City* at a time in the future, chosen by the *City* in its sole discretion, to construct such *Works and Services*.
- 4.3 Prior to the construction or installation of any *Works and Services*, the *Owner/Developer* shall submit for approval two (2) sets of engineering drawings in accordance with Schedule B. If the drawings are satisfactory, one set will be stamped "Approved for Construction" by the *City Engineer* and returned to the *Owner/Developer*. "Approved for Construction" engineering drawings shall be valid for a period of twelve (12) months.
- 4.4 All *Works and Services* shall be installed by the *Owner/Developer* to the *Parcel Line* or the extension thereof of the *Subdivision* or *Parcel* being developed that is furthest from the existing termination point of *Works and Services* except
- 4.4.1 where it is essential that *Works and Services* be extended beyond the *Subdivision* or *Parcel* to tie into *City* water mains, sanitary sewer mains, storm sewer mains or drainage systems; or
  - 4.4.2 where in the opinion of the *City Engineer* extension of a particular work or service would result in unutilized infrastructure, in which case the work or service shall terminate at the point specified by the *City Engineer*; or
  - 4.4.3 where the *Approving Officer* has approved a phased *Subdivision* with a separate plan of *Subdivision* required for each phase, in which case the *Works and Services* need be constructed only to the *Parcel Line* in the current phase that is furthest from the existing termination point.
- 4.5 All *Works and Services* which are to become the property of the *City*, shall, unless situated upon, over or under a *Highway*, be the subject of a grant of statutory right-of-way in a form acceptable to the *City*.

- 4.6 Unless otherwise specifically approved by the *City Engineer*, the design and construction of new or modifications to existing pump stations, control stations, meter stations, and reservoirs for the *City's* water and sewer utilities shall be undertaken by the *City*. Where *Owner/Developers* are under this bylaw financially responsible for the work, they shall post adequate security prior to the *City* commencing work, in the amount estimated by the *City Engineer* as the cost of the work, in the form of cash or an irrevocable letter of credit. Any deficiency in the security in relation to the actual cost of the work shall be a debt of the *Owner/Developer* to the *City*, and any surplus shall be returned to the *Owner/Developer*.
- 4.7 Upon completion of all *Works and Services*, the *Owner/Developer* shall be responsible for and shall make good all defects, imperfections, or deficiencies which become apparent, during the one-year period following the date of issuance by the *City Engineer* of a Certificate of Substantial Completion in respect of the *Works and Services* (the "Maintenance Period").
- 4.8 Should the *Owner/Developer* or *Contractor* fail to make good any defects, imperfections, or deficiencies after being given at least seven days notice in writing by the *City Engineer* during the Maintenance Period, the *City* shall be entitled to make alternative arrangements for the execution of the repairs and to recover the costs from the *Owner/Developer* or *Contractor*.
- 4.9 Upon expiration of the Maintenance Period and correction of all deficiencies and defects in the *Works and Services*, the *City Engineer* shall return any unused security to the *Owner/Developer*.
- 4.10 All traffic signage and pavement markings required on *City* property or lands to be transferred to the *City* will be installed by the *City* at the *Owner's* expense. Where required by the *City Engineer*, the *Owner/Developer's* engineering consultant shall provide traffic signage and pavement marking drawings to the *City*.

TABLE 1: Service Levels for Subdivision and Development (1)

SERVICE	SERVICE LEVEL	DEVELOPMENT AREA					
		Urban	Rural	Industrial	Light Industrial	City Centre	Urban Hillside
Highways:  Road Standards, including curb, gutter, paving, etc. shown on applicable specification drawing. Collector and Arterial Road Standards shall be applied where designated in the <i>Official Community Plan</i>	RD-1 - Urban Local (18m)	X					X
	RD-2 - Urban Local (20m)	X					X
	RD-3 - Urban Collector (20m)	X					X
	RD-4 - Urban Arterial (25m)	X (7)					X (7)
	RD-5 - Town Centre (Varies)	X				X	
	RD-6a - Industrial Area (20m)			X			
	RD-6b - Light Industrial (20m)				X		
	RD-7 - Rural Local (20m)		X				
	RD-8 - Rural Collector (20m)		X	X			
	RD-9 - Rural Arterial (25m)		X (7)	X (7)			
	RD-14 - Canoe Beach Drive (20m)	X					
	RD-15 - Urban Local Hillside (18m)						X
	RD-16 - Urban Single Lane Local Hillside (12m)						X
Road dedication	Based on applicable road cross-section (2)	X	X	X	X	X	X
Water	City Water System including fire hydrants	X	(8)	X	X	X	X
	Alternate Water Supply		X (6)				
Sanitary	City Sewer System	X		X (3)	X (3)	X	X
	Sewage Disposal to Ground System		X	X	X		
Storm	City Storm Sewer System	X		X	X	X	X
	Open Channel System	X (10)	X	X	X		X (10)
	Ground Discharge	X (10)	X	X	X		X (10)
Hydro, Telecommunications (Civil Works Required)	Overhead Distribution to Property Line	(4)	X	X	X		(4)
	Underground Distribution to Property Line	X (5)				X (5)	X (5)
	Overhead Service (within lot)	(4)	X	X	X		(4)
	Underground Service (within lot)	X				X	X
Natural Gas (Optional)	Underground	X	X	X	X	X	X
Street Lighting	Schedule B, Part 1, Section 8.0	X	(9)	X	X	X	X
Sidewalk/Multi-use Path (11)	One Side (Limited Local)	X	X	X	X		X
	Two Sides (inc. high & medium density local)	X				X	X
Bike Lanes / Paved Shoulders (11)			X	X			
Street Tree & Blvd. Appurtenances	Street Trees/Park Benches/Planters					X	
Trail and Roadside Corridors	CGS-7 to CGS-12	X	X	X	X	X	X

- 1 The applicable service level is indicated with an X.
- 2 Dedication is capped at a 20 metre wide ROW and is not required for *Development*. Statutory ROW may be required to accommodate infrastructure.
- 3 Required where the *City* system is within 100 metres and a gravity connection is possible.
- 4 Small *Subdivisions* and *Developments* do not require underground distribution where they are in an area of existing overhead distribution and the *City Engineer* in consultation with BC Hydro approves overhead works.
- 5 Three-phase BC Hydro distribution to be located underground only where a tri-party cost sharing agreement is in place between the *Owner/Developer*, BC Hydro and the *City*.
- 6 The *Owner/Developer* is required to grant a potable water treatment covenant in a form acceptable to the *Approving Officer*.
- 7 The *Owner/Developer* is to construct adjacent arterial road *Frontage* with one traffic lane (second lane funded by *City* if required).
- 8 Extension of municipal system into the rural area is permitted where supported by the OCP.
- 9 If street lighting is required for safety purposes. Rural Street lighting covered under Policy 5.5.
- 10 With specific approval from the *City Engineer* as part of an integrated stormwater management plan. *Owner/Developer* may be required to grant an Alternative Stormwater maintenance covenant in a form acceptable to the *Approving Officer* and the *Director of Development Services*.
- 11 Sidewalk, Multi-use Paths and Bike lanes shall be installed as per the appropriate road cross-section where indicated in the OCP

5.0 EXEMPTIONS

Exemptions to the servicing requirements in Section 4.0 are permitted as follows:

5.1 At the time of *Parcel Line Adjustment*, the provision of new *Works and Services* shall not be required where:

5.1.1 Existing *Works and Services* have sufficient capacity for any demands directly attributable to the proposed *Parcel Line Adjustment*.

5.2 At the time of *Development*, paving of a *Street* shall not be required where:

5.2.1 The *Development* is located in a Rural Development Area; and

5.2.2 The *Development* has *Frontage* on a *Street* constructed to a gravel standard in accordance with Schedule B (Specification Drawing No. RD-7).

5.3 At the time of *Development*, the provision of new *Works and Services* shall not be required where:

5.3.1

a) The *Development* is limited to the construction of an addition to a *Low Density Residential Dwelling* or the construction of a *Building or Structure* accessory to a *Low Density Residential Dwelling*; and

b) Existing *Works and Services* have sufficient capacity for any demands directly attributable to the proposed *Development*.

5.3.2

a) The *Development* is limited to the construction of an addition or the construction of a *Building or Structure* accessory to any existing building not addressed in Section 5.3.1;

b) The size of the addition or accessory building is equal to or lesser than 50 m<sup>2</sup>; and

c) Existing *Works and Services* have sufficient capacity for any demands directly attributable to the proposed *Development*.

5.3.3

a) The *Development* is limited to a façade upgrade or internal renovation on any existing *Building*; and

b) Existing *Works and Services* have sufficient capacity for any demands directly attributable to the proposed *Development*.

- 5.4 At the time of *Subdivision*, the provision of underground distribution wiring, ornamental street lighting, constructed *Highways* including curb and gutter, sidewalks, trails, roadside corridors, *Boulevards* and signage shall not be required where:
- 5.4.1 The *Subdivision* is located in an Urban Development Area;
  - 5.4.2 The *Parcel* being subdivided is zoned and intended for a *Low Density Residential Development*;
  - 5.4.3 The total *Parcel* area is less than 1800m<sup>2</sup>;
  - 5.4.4 New *Street* or *Street* extensions are not required to service the *Subdivision*; and
  - 5.4.5 Existing *Works and Services* have sufficient capacity for any demands directly attributable to the proposed *Development*.
- 5.5 At the time of *Development*, the provision of underground distribution wiring, ornamental *Street* lighting, paved frontage roads, curb and gutter, sidewalks, trails, roadside corridors, *Boulevards* and signage shall not be required where:
- 5.5.1 The *Development* is zoned and intended for construction of a *Low Density Residential Development*;
  - 5.5.2 New *Highways* or highway extensions are not required to service the *Development*; and
  - 5.5.3 Existing *Works and Services* have sufficient capacity for any demands directly attributable to the proposed *Development*.
- 5.6 At time of *Development* where a sanitary main extension would be required to provide the sanitary connection under Section 4.1 of this bylaw, connection to the City sanitary sewer system shall not be required where:
- 5.6.1 The *Development* is located in an Urban Development Area;
  - 5.6.2 The *Development* is zoned and intended for the construction of a *Low Density Residential Development* or the construction of an addition to a *Low Density Residential Development* or the construction of a *Building* or *Structure* accessory to a *Low Density Residential Development*;
  - 5.6.3 The closest point of the subject property is greater than 100 metres away from the closest accessible termination of the City sanitary sewer system.
  - 5.6.4 New highways or highway extensions are not required to service the development; and
  - 5.6.5 The Owner/Developer agrees to install an on-site sanitary collection and treatment system in accordance with the Sewerage System Regulation.

CITATION AND REPEAL

- 5.7 "City of Salmon Arm Subdivision and Development Servicing Bylaw No. 4163" and amendments thereof are hereby repealed.
- 5.8 This bylaw may be cited as "City of Salmon Arm Subdivision and Development Servicing Bylaw No. 4293"

READ A FIRST TIME THIS	12th	DAY OF	June	2023
READ A SECOND TIME THIS	12th	DAY OF	June	2023
READ A THIRD TIME THIS	26th	DAY OF	June	2023
ADOPTED BY THE <i>COUNCIL</i>	26th	DAY OF	June	2023

"A. HARRISON"  
MAYOR

"S. WOOD"  
CORPORATE OFFICER

# **Subdivision and Development Servicing Bylaw No. 4293**

## **Schedule “A”**



## **CITY OF SALMON ARM**

### **MAP 1**

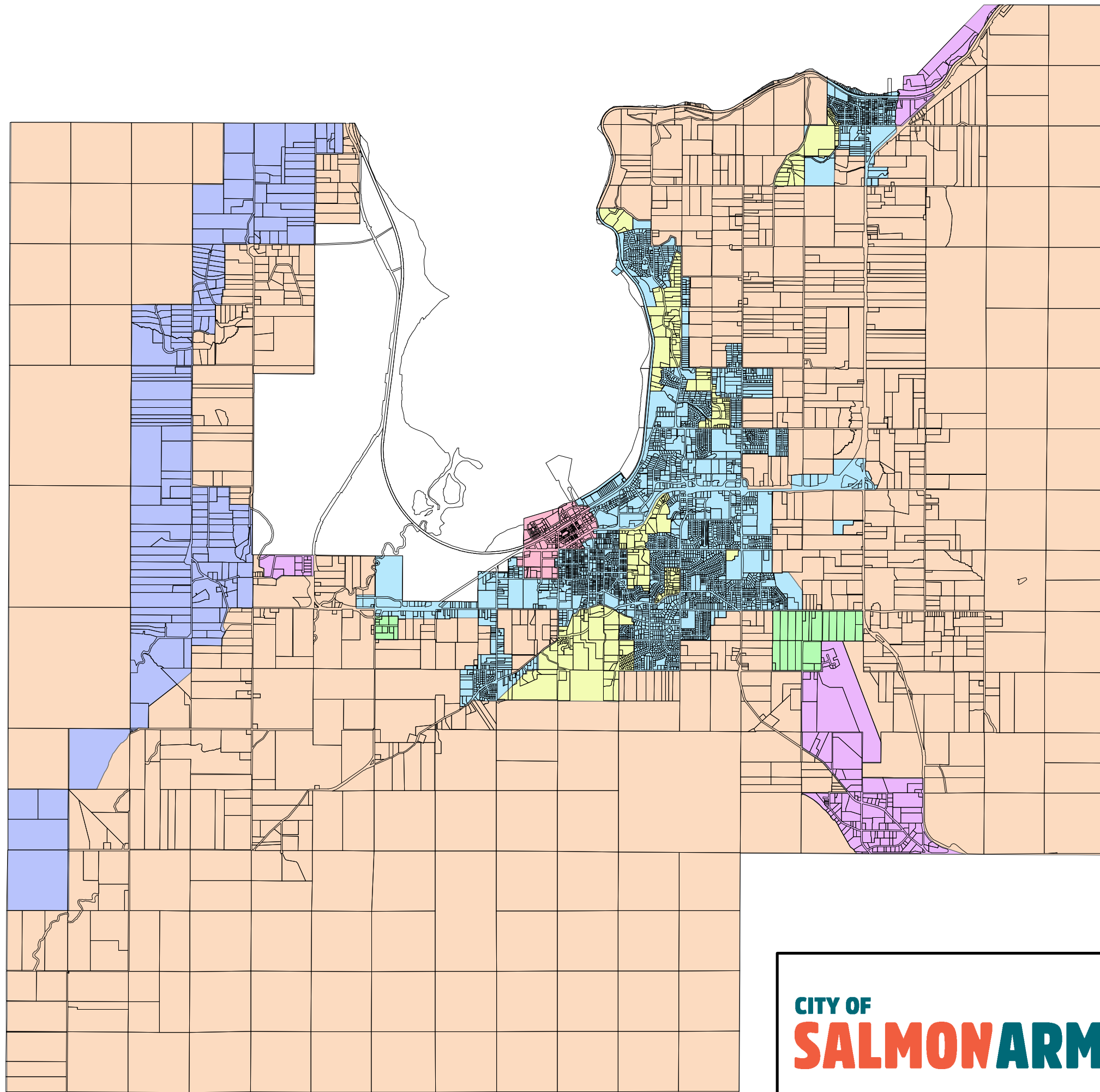

**Legend**

- Industrial Development Area
- Light Industrial Development Area
- Rural Development Area
- Urban Development Area
- Town Centre Development Area
- Rural Hillside Development Area
- Urban Hillside Development Area

- NOTE:**
1. In the event of a discrepancy between this Schedule 'A' Bylaw No. 4163 and the Official Community Plan land maps, the land mapping shall take precedence.
  2. Where the boundary between an "Urban Development Area" and a "Rural Development Area" is shown to be along a highway, the entire highway right-of-way is deemed to be within the "Urban Development Area"
  3. A more detailed map is available for viewing on the City of Salmon Arm's Geographical Information System at City Hall or at <https://salmonarm.ca/>
  4. Roadways along the boundary of two different development areas shall meet the higher service level standard.



SCHEDULE A

---

SUBDIVISION AND DEVELOPMENT  
SERVICING BY-LAW No. 4293

Scale:  
1:55,000

---

Map: **1**  
February 12, 2020



# **Subdivision and Development Servicing Bylaw No. 4293**

## **Schedule “B” – Part 1**



## **CITY OF SALMON ARM**

### **DESIGN CRITERIA**

---

**Contents**

1.0 INTRODUCTION ..... 11

    1.1 The Use of This Design Criteria Manual..... 11

    1.2 Intent of These Standards ..... 11

    1.3 Application of These Design Criteria ..... 11

    1.4 Revisions to These Design Criteria ..... 12

    1.5 Interpretation of the Design Criteria ..... 12

    1.6 Statutory Requirements for Approvals..... 12

    1.7 Certifications ..... 12

2.0 PRE-DESIGN, DESIGN and CONTRACT ADMIN ..... 13

    2.1 Legal Surveys ..... 13

    2.2 Design Surveys..... 13

    2.3 Geotechnical Report ..... 13

        2.3.1 Category A - Building foundation design and site drainage ..... 13

        2.3.2 Category B - Pavement Structural design for private access corridors and public roads 14

        2.3.3 Category C - Landslide Assessments for Proposed Development ..... 14

    2.4 Flood Risk Assessment ..... 14

    2.5 Traffic Impact Analysis ..... 14

    2.6 Qualified Professional Engineer ..... 15

    2.7 Design Drawing Submission ..... 15

    2.8 Design Drawings..... 15

        2.8.1 Submission Set..... 16

        2.8.2 Existing Information ..... 17

        2.8.3 Drawing Scale..... 17

    2.9 Design Drawing Approval..... 17

    2.10 Pre-Construction Requirements ..... 17

        2.10.1 General..... 17

        2.10.2 Documentation..... 18

    2.11 Post Construction and City Acceptance ..... 18

        2.11.1 Construction Completion Report ..... 18

        2.11.2 Substantial Completion ..... 19

        2.11.3 Deficiencies ..... 19

---

2.11.4	Record Drawings: .....	19
2.11.5	Utility Service Cards.....	20
2.11.6	Submission Deadlines .....	20
2.11.7	Final Acceptance .....	20
3.0	SITE PREPARATION AND EARTHWORKS .....	21
3.1	Erosion and Sediment Control (ESC).....	21
3.1.1	Erosion and Sediment Control Drawings.....	21
3.1.2	Process.....	21
3.1.3	ESC Plan Requirements .....	21
3.1.4	ESC Best Management Practices .....	22
3.2	Site Grading.....	23
3.2.1	Site Grading Plan.....	23
3.2.2	Low Points .....	23
3.2.3	Overland flow routes .....	23
3.2.4	Cut/fill plan.....	24
3.2.5	Slope .....	24
3.2.6	Lot Grading .....	24
3.2.7	Swales.....	24
3.2.8	Retaining Walls.....	25
3.2.9	Statutory Right-of-ways.....	25
3.2.10	Rough Grading .....	25
3.3	Site Restoration .....	25
3.3.1	Restoration of Public Property .....	25
3.3.2	Restoration of Private Property .....	25
3.3.3	Restoration of Site .....	25
4.0	ROADS .....	27
4.1	General.....	27
4.2	Approval Drawings.....	27
4.3	Geotechnical Evaluation .....	27
4.4	Road Classification .....	27
4.5	Design Speed .....	27
4.6	Right of Way Widths .....	28
4.6.1	Standard Right-of-way Widths .....	28
4.6.2	Additional Right-of-way Width .....	28

---

4.6.3	Reduced Right of Way widths .....	28
4.6.4	Corner Cuts .....	28
4.7	Lanes.....	28
4.8	Cross-Sectional Elements.....	28
4.8.1	Road Cross-Section.....	28
4.8.2	Road Structure.....	28
4.8.3	Boulevards.....	29
4.8.4	Bike lanes .....	29
4.8.5	Ditches.....	29
4.8.6	Curb and Gutter .....	29
4.8.7	Sidewalks and Multi-use Paths .....	29
4.8.8	Walkways .....	30
4.8.9	Crosswalks .....	30
4.8.10	Stairs .....	30
4.8.11	Pathways and Trails.....	30
4.8.12	Canada Post Boxes .....	30
4.8.13	Transit Bays.....	31
4.8.14	Parking Bays.....	31
4.8.15	Sign Post Bases .....	31
4.9	Alignment Elements.....	31
4.9.1	Cross Slopes .....	31
4.10	Intersection Design .....	32
4.10.1	Round-Abouts.....	32
4.10.2	Maximum Grade .....	32
4.10.3	Angle .....	32
4.10.4	Curb Returns .....	32
4.11	Cul-De-Sacs .....	32
4.11.1	General.....	32
4.11.2	Grading.....	32
4.11.3	Driveways .....	32
4.11.4	Length.....	33
4.12	Pavement Marking and Signage .....	33
4.13	Access .....	33
4.13.1	Driveways .....	33

---

4.13.2	Combined/Shared Access.....	33
4.13.3	Number of Accesses.....	33
4.13.4	Clearance to Intersection.....	34
4.13.5	Servicing Conflicts.....	34
4.13.6	Grade.....	34
5.0	WATER SYSTEMS.....	35
5.1	General.....	35
5.1.1	Water for Domestic Purpose.....	35
5.1.2	Municipal or Alternative Water Source.....	35
5.1.3	Extension of Water Distribution System.....	35
5.2	Alternative Water Source.....	35
5.2.1	Alternative Water Source Approval for Subdivision or Development.....	36
5.2.2	Professional Driven Approach (Groundwater).....	36
5.2.3	Homeowner Driven Approach (Groundwater).....	37
5.2.4	Surface Water.....	37
5.2.5	Water Quality Testing.....	38
5.2.6	Covenant.....	38
5.2.7	Proof of Source Yield (Groundwater).....	38
5.2.8	Proof of Source Yield (Surface Water).....	38
5.2.9	Water Treatment.....	39
5.3	Municipal Water Source.....	39
5.3.1	City of Salmon Arm.....	39
5.3.2	Interior Health Authority.....	39
5.4	Main Sizing.....	40
5.4.1	Pipe Flow Formula.....	40
5.4.2	Minimum watermain sizes.....	40
5.4.3	Design velocity.....	40
5.4.4	Per Capita Demand.....	40
5.4.5	Non-Residential Demand.....	40
5.4.6	Fire Flow Requirements.....	41
5.4.7	Design Flows.....	41
5.4.8	Design Pressures.....	41
5.5	Vertical Alignment.....	41
5.5.1	Grade.....	41

---

5.5.2	Chambers .....	41
5.5.3	High Points .....	42
5.5.4	Air Release and Vacuum Valve .....	42
5.5.5	Depth of Cover.....	42
5.5.6	Vertical Clearance .....	42
5.6	Horizontal Alignment.....	42
5.6.1	Location in Roadway.....	42
5.6.2	Horizontal Curves .....	42
5.6.3	Horizontal Clearance .....	43
5.6.4	Chambers .....	43
5.6.5	Main Looping .....	43
5.6.6	Dead End Watermain.....	43
5.7	Main Line Valve Size and Locations .....	43
5.8	Fire Hydrants .....	44
5.8.1	Spacing.....	44
5.8.2	Location/Clearance.....	44
5.8.3	Connections.....	44
5.8.4	Depth of Cover.....	44
5.9	Thrust Blocks and Joint Restraints.....	44
5.10	Water Services .....	45
5.10.1	Number of Connections .....	45
5.10.2	Diameter .....	45
5.10.3	Minimum Pressure .....	45
5.10.4	Pressure Reducing Valves.....	45
5.10.5	Curb Stop Location .....	45
5.10.6	Tracer wire.....	45
5.11	Water Meters .....	46
5.11.1	Water Meters .....	46
5.11.2	Credit Meters .....	46
5.11.3	Meter Vaults .....	46
5.12	Valve Box Marker.....	46
5.13	Pump Stations Control Valves and Reservoirs.....	46
5.14	Corrosion Protection .....	46
5.15	Cross Connection Control .....	47

---

5.16	Abandonment of Mains .....	47
6.0	SANITARY SEWER SYSTEM.....	48
6.1	General.....	48
6.1.1	Sanitary connection .....	48
6.1.2	Municipal or Alternative Sanitary System .....	48
6.2	On-site Sanitary Systems.....	48
6.3	Municipal Sanitary System.....	48
6.3.1	Engineering Drawings.....	48
6.3.2	Design Sheets .....	48
6.4	Main Sizing .....	49
6.4.1	Design Flow .....	49
6.4.2	Population.....	49
6.4.3	Average Dry Weather Flow .....	49
6.4.4	Peak Flow Formula.....	49
6.4.5	Infiltration .....	49
6.4.6	Pipe Flow Formula Gravity Main .....	49
6.4.7	Pipe Flow Formula Force Main .....	50
6.4.8	Minimum sanitary main diameter .....	50
6.4.9	Velocities .....	50
6.5.1	Pipe Grade .....	50
6.5.2	Hydraulic Losses Across Manholes .....	51
6.5.3	Drop Manholes .....	51
6.5.4	Depth of Cover.....	51
6.5.5	Vertical Curves .....	51
6.5.6	Manhole Benching .....	51
6.6.1	Location in Roadway.....	51
6.6.2	Horizontal Curves .....	52
6.6.3	Sanitary Manholes .....	52
6.6.4	Clean-outs .....	52
6.7	Service Connections .....	52
6.7.1	Number of Services .....	52
6.7.2	Diameter .....	52
6.7.3	Depth and Grade .....	53
6.7.4	Connection into Manhole .....	53

---

6.7.5	Inspection Chambers .....	53
6.8	Force Mains .....	53
6.8.1	Diameter .....	53
6.8.2	Velocity .....	53
6.8.3	High Points .....	53
6.8.4	Tracer Wire .....	53
6.8.5	Connection to Manhole .....	53
6.9	Pump Stations .....	54
7.0	STORM WATER MANAGEMENT .....	55
7.1.1	Integrated Stormwater Management Plan .....	55
7.1.2	Municipal or Alternative Storm System .....	56
7.2	Alternative Stormwater Systems .....	56
7.2.1	Sheet Drainage .....	56
7.2.2	Infiltration Systems .....	56
7.2.3	Low Impact Development Infrastructure .....	57
7.2.4	Covenant .....	57
7.2.5	Statutory Right of Way .....	57
7.3	Municipal Stormwater Collection System .....	57
7.3.1	Engineering Drawings .....	58
7.3.2	Stormwater Report .....	58
7.3.3	Design Sheets .....	58
7.4	Design Flows .....	58
7.4.1	Major and Minor Flow Calculations .....	58
7.4.2	Peak Rate Run-off (Design Storms) .....	58
7.4.3	Pre-development Flow .....	59
7.4.4	Run-off Coefficient .....	59
7.4.5	Rainfall Intensity .....	59
7.4.6	Design Time of Concentration .....	60
7.4.7	Snow Melt .....	60
7.5.1	Design Storm .....	60
7.5.2	Pipe Flow Formula .....	60
7.5.3	Minimum Storm Main Diameter .....	61
7.5.4	Velocities .....	61
7.5.5	Design Flow Adjustment for LIDs .....	61



---

7.6	Vertical Alignment.....	61
7.6.1	Pipe Grade .....	61
7.6.2	Hydraulic Losses Across Manholes .....	61
7.6.3	Drop Manholes .....	62
7.6.4	Depth of Cover.....	62
7.6.5	Vertical Curves .....	62
7.6.6	Manhole Benching .....	62
7.7	Horizontal Alignment.....	62
7.7.1	Location in Roadway.....	62
7.7.2	Horizontal Curves .....	62
7.7.3	Storm Manholes.....	62
7.7.4	Clean-outs .....	63
7.8	Service Connections .....	63
7.8.1	Number of Services .....	63
7.8.2	Diameter .....	63
7.8.3	Depth and Grade .....	63
7.8.4	Connection into Manhole .....	63
7.8.5	Inspection Chambers .....	64
7.10.1	Spacing.....	64
7.10.3	Side Inlets.....	64
7.10.4	Catchbasin Leads .....	64
7.10.5	Location.....	65
7.10.6	Rear Yard Catchbasin.....	65
7.11	Major Flow Routing .....	65
7.11.1	General.....	65
7.11.2	Design Storm .....	65
7.11.3	Major Route Flow Sizing .....	66
7.11.4	Location .....	66
7.11.5	Major Flow on Roadways.....	66
7.11.6	Erosion Protection .....	66
7.11.7	Storm Sewer .....	66
7.12	Hydraulic Grade Line .....	66
7.12.1	General.....	66
7.12.2	Hydraulic Grade Line Formula .....	67

---

7.12.3	Inlet Control Devices.....	67
7.13	Drainage Ditches/Culverts .....	67
7.14	Inlet and Outlet Structures .....	67
7.14.1	General.....	67
7.14.2	Safety Grates and Hand Rails.....	68
7.14.3	Erosion Control .....	68
7.15	Quality Control.....	68
7.15.1	General.....	68
7.15.2	Oil/Water Separators (OWS).....	68
7.15.3	Oil/grit Separators (OGS).....	68
7.15.4	Detention Storage Facilities .....	69
7.16	Quantity Control.....	69
7.16.1	General.....	69
7.16.2	Detention Facilities.....	69
7.16.2.1	Above Ground Detention .....	69
7.16.2.2	Underground Detention .....	69
7.16.2.3	Private Detention Facilities .....	69
7.16.3	Orifice .....	70
7.16.4	Infiltration Systems.....	70
7.16.5	Low Impact Development Infrastructure.....	70
7.16.6	Natural Drainage Courses.....	70
8.0	STREET LIGHTING .....	71
8.1	British Columbia Electrical Code .....	71
8.2	Materials .....	71
8.3	Levels of Illumination .....	71
8.4	Pole Type .....	71
8.5	Location .....	72
8.6	Electrical Service Connections.....	72
8.7	Electrical Permit.....	72
9.0	HYDRO, TELECOMMUNICATIONS, GAS.....	73
9.1	General.....	73
9.2	B.C. Hydro .....	73
9.3	Telecommunications .....	73
9.4	Gas Distribution System.....	73

---

10.0 LANDSCAPING.....74

    10.1 General.....74

    10.2 Approval Drawings.....74

    10.3 Boulevards.....74

    10.6 Seeding .....75

    10.8 Street Trees.....75

    10.9 Unit Paving .....75

11.0 HILLSIDE DEVELOPMENT.....77

    11.1 General.....77

    11.2 Roads .....77

        11.2.1 Single Lane Roadways .....77

        11.2.2 Lanes.....77

        11.2.3 Rights-of-ways .....77

        11.2.4 Sidewalks .....77

        11.2.5 Boulevards.....77

        11.2.6 Turn-around.....78

    11.3 Access .....78

---

**GENERAL:** The following design standards are to be used as requirements of all developments except where otherwise exempt in the bylaw or standards. Where a proposed design meets the level of service prescribed by the bylaw, alternative design solutions may be evaluated and approved at the discretion of the City Engineer.

## **1.0 INTRODUCTION**

### **1.1 The Use of This Design Criteria Manual**

This Design Criteria Manual replaces all previous versions and revisions. Always ensure that you are using the most recent version. It is the Design Engineer's responsibility to verify that the current criteria are being used prior to initiating and submitting detailed design.

### **1.2 Intent of These Standards**

This manual has been prepared for the Design Engineer and the development community for the design of engineering facilities and systems in the City of Salmon Arm. It is intended to provide the minimum design criteria and standards for proposed City works. The Design Engineer remains fully responsible to ensure that designs meet the minimum design criteria, accepted engineering principles, and are adequate for the site conditions and anticipated use.

### **1.3 Application of These Design Criteria**

The minimum criteria and standards defined in this manual shall apply to the preparation of all engineering designs and drawings for projects in the City of Salmon Arm. Design Engineers are encouraged to seek innovative and superior solutions, where appropriate, to achieve better technical and economical solutions. A Design Engineer who wishes to adopt criteria not specifically included in or variant from those within this manual, shall justify the proposed change in a signed and sealed letter/report submitted to the City Engineer for review and approval. Submissions must demonstrate that the proposed change is equivalent to or better than the standards contained in this manual and provides the level of service prescribed by the bylaw.

The Design Engineer must be satisfied that the design criteria contained herein are applicable to the project at hand, and must apply more stringent criteria where appropriate. The Applicant and Design Engineer are fully responsible for designing to standards which exceed these standards when specific site conditions dictate that more stringent performance measures are required. All design and construction details for City infrastructure shall be in accordance with this Design Criteria Manual, the Subdivision and Development Services Bylaw, Fire Prevention Bylaw, other applicable Bylaws and with the Standard Drawings and Specifications, as adopted by the City.

Where conflicts or discrepancies appear between this manual, Standard Drawings and/or Specifications, the Design Engineer shall review the conflict or discrepancy with the City and shall obtain the City's approval to an agreed drawing or specification prior to proceeding. The criteria that shall apply are those in place at the time of the latest letter of Preliminary Layout Approval (PLA) or extensions thereto, in the case of subdivision applications.

---

#### **1.4 Revisions to These Design Criteria**

The criteria and design parameters contained in this manual are subject to review and re-evaluation and the City reserves the right to initiate revisions or additions to these criteria as and when it deems it is necessary to make such revisions.

The City encourages submissions from Design Engineer's wishing to amend the City's Design Criteria. Such submissions shall be in a report format, signed and sealed by a Professional Engineer (where info is technical in nature), and shall include clean and succinct expressions of concern, suggestions for alternatives including benefits and recommendations proposed to address improvements to the current Design Criteria.

The City may, at its sole discretion, review, assess and accept, adopt, or reject in whole or in part, the submissions and/or the recommendations from a Design Engineer for inclusion within the Design Manual at a future date.

#### **1.5 Interpretation of the Design Criteria**

The City Engineer reserves the right to the final decision with regard to the interpretation of the intent of the Design Criteria, and with regard to the acceptability of changes from the Standards, or Standards proposed by the Design Engineer.

#### **1.6 Statutory Requirements for Approvals**

The Design Engineer shall remain responsible for compliance with all the statutory requirements of the City and other relevant authorities which are mandated to regulate and approve such works and shall arrange for and secure all approvals from the appropriate authorities.

Where this Design Criteria Manual refers to: bylaws, acts, regulations and standards, this shall mean the most recent edition or amendment of the referenced document. It is the responsibility of the Design Engineer to ensure the most recent edition of amendment is being used.

Where due to amendment of statutory requirements, conflicts or inconsistencies with this Design Criteria Manual arise, the Design Engineer is responsible for applying the more stringent requirements, and shall refer the issue to the City Engineer.

#### **1.7 Certifications**

Design Engineers shall accept responsibility for all aspects of their design and inspections associated with their design. The Design Engineer must be in good standing and registered with the Engineers and Geoscientists BC (EGBC) and be currently practicing in the appropriate engineering discipline. Additionally the Engineer's Firm must have a Permit to Practice from EGBC. By way of the Design Engineer's seal and Permit to Practice number they are certifying that the works have been designed and inspected to good engineering standards and in accordance with the latest edition of the City of Salmon Arm Design Criteria Manual, Standard Drawings and Specifications adopted by the City of Salmon Arm. All submissions including drawings, reports, calculations, cost estimates, inspection reports or other such information as required are to be submitted under the Design Engineer's seal and signature.

---

## **2.0 PRE-DESIGN, DESIGN and CONTRACT ADMIN**

### **2.1 Legal Surveys**

Project legal survey and preparation of plans for registration at the Land Title Office, shall be completed by a registered British Columbia Land Surveyor (B.C.L.S).

All project legal survey plans prepared by a B.C.L.S shall be submitted in electronic format.

### **2.2 Design Surveys**

Surveys shall be conducted in a manner so as not to create a nuisance to traffic or the general public. The permission of registered property owners is required before entering private property.

All elevations shall be referenced to Geodetic Survey of Canada (GSC) datum.

All drawing coordinates shall be consistent with established survey coordinates to the City's benchmark system.

### **2.3 Geotechnical Report**

Where a geotechnical engineering review is required in accordance with the provisions contained in this bylaw or by the Approving Officer, the Owner/Developer shall appoint a qualified Professional Engineer or Geoscientist to complete a geotechnical investigation and report addressing the potential areas of concern as listed below and as required.

The City requires that all works and services installations shall have a level of safety for any and all geotechnical failures with a 10.0% probability of failure occurring in a 50 year period (a return period of 1:500 year), or the prevailing standard as set by the B.C. Building Code, whichever is more stringent.

The geotechnical report must clearly state that the land is safe for the intended purpose and that the City of Salmon Arm may use and rely on the findings and recommendations contained in the report.

The Owner/Developer shall be responsible for completing the recommended improvements prior to Subdivision or Development and/or may be required to register a Section 219 Restrictive Covenant.

#### **2.3.1 Category A - Building foundation design and site drainage**

- 1) The design engineer shall undertake field investigations for the purpose of classification of the native soils in the laboratory. Where groundwater is prevalent the depth of the groundwater table shall be determined.
- 2) All necessary test pits or boreholes shall be logged and locations accurately shown on a site plan and attached as an addendum to the report.
- 3) The details and results of the laboratory analysis is to be provided in the report. In addition, the engineering properties of the subsoils must also be provided.
- 4) The engineer must review the site and provide a detailed assessment and recommendations for the items below. Where recommendations vary from B.C. Building Code requirements a Section 219 covenant must be registered on title to

---

ensure compliance with geotechnical report and future related works shall be supervised by a qualified engineer.

- a) General grading and site preparation;
- b) Ground preparation for foundation/crawl spaces;
- c) Design specifications for any retaining walls to be constructed;
- d) Foundation perimeter, roof and general site drainage including a recommendation on connecting roof leader drainage to the storm sewer where necessary;
- e) Frost protection for foundations, and
- f) Provide general comments on the constructability of the proposed development and make any additional recommendations deemed necessary to meet the prescribed level of safety.

### 2.3.2 Category B - Pavement Structural design for private access corridors and public roads

- 1) The engineer must complete field investigations, laboratory analysis and reporting as noted in Category “A”, Items 1 and 2.
- 2) The engineer must complete pavement evaluation and design based on the AASHTO guide (latest version) based on a 25 year design life. The pavement structure design must be no less than that recommended in accordance with the provisions contained in this bylaw.
- 3) The report must provide detailed recommendations on the following:
  - a) Subgrade preparations;
  - b) Sub-base, base and asphalt construction methods;
  - c) Construction of sidewalks and curb & gutter, and
  - d) Trench excavation and backfill within road allowances and statutory rights-of-way.

### 2.3.3 Category C - Landslide Assessments for Proposed Development

Where a geotechnical engineering report in reference to a potential land stability risk is required by the Approving Officer, for subdivision approval, issuance of a development or building permit, the report must be conducted in accordance with the “Guidelines for Legislated Landslide Assessments for Proposed Residential Development in British Columbia” as prepared by the Association of Professional Engineers and Geoscientists of BC, as amended.

The Geotechnical Engineer shall provide an APEGBC Appendix D: Landslide Assessment Assurance Statement with the submission of each report and with any revised report.

## **2.4 Flood Risk Assessment**

Where an engineering report in reference to a potential flood risk is required by the Approving Officer, for subdivision approval, issuance of a development or building permit or for a flood plain bylaw exemption, the report must be conducted in accordance with the “Professional Practice Guidelines – Legislated Flood Assessments in a Changing Climate in BC” as prepared by the Association of Professional Engineers and Geoscientists of BC, as amended.

## **2.5 Traffic Impact Analysis**

---

Where a Traffic Impact Analysis (TIA) is required by the Approving Officer, for rezoning or subdivision approval, the Owner/Developer shall appoint a qualified Professional Engineer to complete a TIA and report.

The Terms of Reference for the TIA shall be prepared by the Engineer and submitted to the City for approval prior to proceeding with the TIA. A sample Terms of Reference can be obtained from the City's Engineering Department.

## **2.6 Qualified Professional Engineer**

Where works and services are required in accordance with the provisions contained in this bylaw, the Owner/Developer shall appoint a qualified Professional Engineer hereinafter referred to as the Consulting Engineer, to undertake all project engineering survey, design, field reviews and record drawings in accordance with the provisions of this bylaw. The Owner/Developer shall provide a confirmation of Professional Assurance, Certificate Schedule 'C', F-10 signed by a Professional Engineer

Proof of Engineers Professional Liability Insurance (Errors and Omissions) shall be provided for all projects where the cost of the works and services exceeds One Hundred Thousand Dollars (\$100,000.00)

## **2.7 Design Drawing Submission**

The design drawing submission shall be provided electronically in pdf format and shall also include the following:

- Two (2) complete sets of ANSI 'D' or ARCH 'D' size design drawing prints (See Section 2.8), date stamped, sealed and signed by a Professional Engineer, for approval. All design drawings shall be submitted in the City of Salmon Arm standard format as shown in the Specifications Drawings. Additional sets of drawings are to be submitted upon request at the Owner/Developers cost
- Design sheets and calculations for proposed storm and sanitary sewer installations.
- Construction estimates for (a) off-site works and services and (b) on-site works and services shall be submitted with the design drawings. These construction estimates shall be prepared in a City of Salmon Arm format and shall reflect current construction costs in Salmon Arm and shall be signed and sealed by a Professional Engineer.
- PDF copies of the approved Hydro, Telecommunication, Natural Gas and CATV servicing drawings.
- Provincial Health Certificate to Construct Water Works for water works installations (This is generally received directly from IHA but if not received, will be requested from the Engineer).

## **2.8 Design Drawings**

A description of each of the most commonly required drawings is included below which includes a general guideline of the information to be included on each drawing.



---

### 2.8.1 Submission Set

Where applicable the following design drawings shall be submitted:

- Project Cover Sheet / Key Plan – Shall indicate the Designers Name, Address, telephone and Fax Number, the City's Project Number, the Site Location, the Legal Description of the properties involved, and an Index of the Design Drawings.
- General Notes & Details – Road cross sections on profile drawings, all other miscellaneous details on plan drawings.
- General Arrangement Plan – shall be a plan view drawing(s) at 1:1000 scale or 1:500 as appropriate, showing all existing and proposed infrastructure (including private utility company servicing and street lighting)
- Sanitary Drainage Plan – shall indicate proposed drainage boundaries for each pipe reach and their associated area, design flow/unit, population/unit. All external flows and future flows shall be indicated. Plans shall show basic lot information and all sanitary related infrastructure.
- Storm Drainage Plan – Shall indicate existing and proposed drainage boundaries for each pipe reach and their associated area and runoff coefficient. All external flows and future flows shall be indicated. Plans shall show basic lot information, existing contours, proposed grading and all storm related infrastructure.
- Plan and Profile Drawings – shall contain plan view (top) and profile (bottom) at 1:500 horizontal, 1:50 vertical, road design including curb and gutter, sidewalks and other related surface works, storm and sanitary sewers, service connections and related appurtenances, waterworks, service connections, fire hydrants and related appurtenances. Pipes and manholes shall be drawn at actual size in profile and hatching shall distinguish between water, sanitary and storm. Pipe widths shall be shown in plan view for pipes 600mm in diameter and larger and in profile view for all pipe diameters.
- Grading Plan – shall thoroughly detail any changes to existing grading both on-site and off-site. The plan shall provide adequate information to confirm overland flow patterns and routes, conformity to City design standards, impacts to adjacent lots, and constructability of lot (refer to Section 3.2.1). Pre-grade values shall be provided for lots that are less than three (3) times the minimum lot sizes. Pre-grade values are the depths below final grade that lots/roads should be left at pre-development to account for excavation spoils during construction bringing the site up to the final approved grade.
- Pavement Marking and Signage Plan – shall indicate all required pavement marking and signage including all required layout dimensioning.
- Utility Coordination Plan – shall indicate locations of all shallow utilities (hydro, tel, cable, gas), road crossing locations and all above ground appurtenances such as pedestals, transformers, street lights, manholes, hydrants, street trees, inspection chambers, etc.

- 
- Illumination Plan – shall indicate lamp locations, lamp (LED) types, spacing, areas of illumination and calculations. Illumination plan may require an exclusive site plan or may be included on General Arrangement Plan, depending on complexity of proposed work.
  - Erosion and Sediment Control Plan – shall indicate all erosion and sediment control infrastructure and appurtenances (refer to Section 3.1).
  - Landscaping and Irrigation Plan – shall indicate the location of the irrigation system and appurtenances as well as any proposed plantings (refer to Section 10.0).
  - Lot Grading Plan (Building Permits) – shall thoroughly detail any changes to existing grading both on-site and off-site and any deviations from the approved grading plans. The plan shall provide adequate information to confirm overland flow patterns and routes, building elevation, conformity to City design standards, impacts to adjacent lots, driveway slopes, boulevard slopes, and constructability of lot (refer to Section 3.2.1).

Where colours are used on drawings, they should conform to best practices (sanitary is red, storm is green, water is blue).

#### 2.8.2 Existing Information

Existing information shall be illustrated with grayed back line work and/or dashed line types.

#### 2.8.3 Drawing Scale

The scale of all design drawings with exception of the general arrangement drawing shall be 1:500 Horizontal, 1:50 Vertical. Any deviation shall be first approved by the City Engineer.

### **2.9 Design Drawing Approval**

City review and acceptance of Engineering Plans does not confirm the accuracy or adequacy of the design; nor does the City accept responsibility for any damages or costs incurred due to errors, omissions, or deficiencies in the design or location of any existing or new works and services.

### **2.10 Pre-Construction Requirements**

#### 2.10.1 General

No construction shall occur unless and until engineering drawings have been accepted by the City. Such acceptance is indicated only by the signature of the City Engineer, or authorized delegate on the submitted design drawings and completed Permission to Construct, Schedule 'C', Form F-1. These drawings shall be referred to as the "CSA Approved Design Drawings".

---

### 2.10.2 Documentation

The Owner/Developer shall provide the following documentation after acceptance of the Engineering Submissions and before commencing any works within City of Salmon Arm rights of way as follows:

- A signed and sealed Servicing Agreement where required by the City Engineer.
- Proof of Insurance in accordance with the terms and conditions provided in the Servicing Agreement, naming the City of Salmon Arm as an 'Additional Insured'.
- Performance Security equal to 125% of the estimated off-site servicing costs (cash or clean irrevocable letter of credit).
- Professional Assurance Certificate, Schedule 'C', Form F-8, signed by a Professional Engineer.
- A copy of the Work Safe BC 'Notice of Project' and 'Letter of Good Standing'
- Prime Contractor Pre-construction Form, duly completed.
- A testing schedule for quality control of the constructed works including the name of the testing agency and the contact person.
- Outside Provincial and Federal Resource Agency approvals obtained (Ministry of Transportation, Ministry of Environment, Ministry of Health, Department of Fisheries and Oceans, etc.), where applicable.

## **2.11 Post Construction and City Acceptance**

### 2.11.1 Construction Completion Report

Following completion of the works and services, the Consulting Engineer shall submit an electronic construction completion report to the City Engineer that contains the following documentation:

- Certificate of Inspection, Schedule 'C', Form F-2, signed and sealed by the Consulting Engineer.
- Inspection Records, including photos.
- Complete Materials and Performance Testing Report for all construction work (i.e., earthwork compaction, asphalt marshal/compaction densities, concrete testing, sewer leakage and pressure test, etc.) and (water system leakage and pressure test, bacteriological test results and certification in accordance with Flushing/Testing/Disinfection Report, Schedule 'C', Form F-11). All materials testing reports shall be sealed and signed by a professional Engineer certifying that all works tested meet and/or exceed the requirement of this bylaw;
- Fire Hydrant Flow Testing, Colour Coding and Stamping will be completed by the City's Utility Department, at the Owner/Developer's cost.

- 
- Hydro, Telecommunications, Natural Gas and CATV acceptance letters of the completed work;
  - Permit from Technical Safety BC for the completed streetlight/electrical system (this must be submitted within three (3) months of installation);
  - IHA Construction Permit issued under Section 7 of the Drinking Water Protection Act;
  - Signed 'Certificate of Reinstatements' from registered property owners where works have been undertaken on private property.
  - Confirmation that all residents who have been directly affected by the works have been notified of the project completion and given the City's contact information should issues arise.
  - Utility videos, complete with inspection report for all new sanitary and storm sewer installations;
  - Confirmation that Canada Post has been notified of the completed subdivision/development;
  - Certification that the rough lot grading has been completed to within +/- 100 mm of the approved final pre-grades;

#### 2.11.2 Substantial Completion

On completion of the Works and Services the Owner/Developer shall notify the City Engineer. The City Engineer, upon receipt of the notice and bound completion report prepared by the Consulting Engineer, shall inspect the Works and Services and, if necessary, issue a list of deficiencies that must be corrected. If the City Engineer determines the works and Services can be put into service and are substantially complete, a Certificate of Substantial Completion, Schedule 'C', Form F-4 shall be dated and issued. At this time monies held by the city shall be released, less 10% of the total cost of the Works and Services as a maintenance holdback and deficiency bonding as noted in Section 2.11.3.

#### 2.11.3 Deficiencies

Any deficiencies identified upon substantial completion shall be bonded in the amount of two (2) times the value of the deficiencies. Upon correction of the deficiencies, to the acceptance of the City Engineer, a Certificate of Completion, Schedule 'C', Form F-5 shall be dated and issued and the deficiency portion of the maintenance holdback released.

#### 2.11.4 Record Drawings:

At the conclusion of the project, and prior to release of the Owner/Developers Performance Security, the Owner/Developer shall submit one (1) set of Record Drawings which have been revised, sealed and signed by a Professional Engineer, to illustrate the recorded works, plus an electronic copy containing the record drawings in AutoCAD DXF format and PDF format.

---

Record drawings, means design drawings sealed by a Professional Engineer to reflect design changes made during construction. These drawings are intended to incorporate addenda, change orders and other significant design changes and site instructions. These drawings must be signed, sealed and dated by the professional Engineer who assumes overall responsibility for the construction and must be provided whether private contractor or City crews installed the work.

Record Drawings shall indicate the installed location for Hydro, Telecommunications, Gas, CATV and Street Lighting mains and servicing.

#### 2.11.5 Utility Service Cards

Utility Service Cards shall be submitted in accordance with Specification Drawing No. SC-1 indicating the exact location and size of the water, sanitary and storm services, the lot and plan number, the street name, civic address, north arrow, lot lines, dimensions and bearings. Utility Service Card shall be submitted for each lot created by subdivision and/or the Development at the time of submission of the Record Drawing and must be provided whether private contractor or City crews installed the work.

UTM 11 coordinates are to be provided for water service curb stop, sanitary service inspection chamber and storm service inspection chamber, in addition to dimensions to property lines and/or property pins.

Utility Service Cards shall be submitted in PDF format with one (1) PDF file for each parcel. The file names shall follow the City standard format of all capitals, full road name, no use of suffixes on road number (ie 3200 3 STREET NE).

#### 2.11.6 Submission Deadlines

All record drawings and utility service cards shall be submitted to the City within 90 days of issuance of a 'Certificate of Substantial Completion' to the Owner/Developer, otherwise the City may, at their discretion, proceed with preparation and completion of the aforementioned information at the cost to the Owner/Developer

#### 2.11.7 Final Acceptance

The City Engineer will release the maintenance holdback, less the cost of any repairs chargeable to the Owner/Developer, upon expiration of the maintenance period when so requested by the Owner/Developer. Upon release of the maintenance holdback the City Engineer will issue a Certificate of Final Acceptance, Schedule 'C', Form F-6

---

### **3.0 SITE PREPARATION AND EARTHWORKS**

#### **A. DESIGN CRITERIA**

#### **3.1 Erosion and Sediment Control (ESC)**

##### **3.1.1 Erosion and Sediment Control Drawings**

Erosion and Sediment Control Plans will be required as part of the submission set for all subdivision and development proposals where ground disturbance is required. Plans will be designed using Best Engineering Practices to protect adjacent properties and City Infrastructure from adverse effect of erosion and/or sediment deposition to the satisfaction of the City Engineer.

The Erosion and Sediment Control plan should seek (i) to protect the soil surface from erosion where possible and (ii) capture all sediment on-site during each phase of the construction project. This includes requirements to control the amount, water quality, and velocity of runoff to ensure that no excessive sediment laden water is discharged, either directly or indirectly, into the City Drainage System or into the watercourses.

##### **3.1.2 Process**

A Professional engineer must review, sign, and seal the ESC plan to confirm the plan complies with the applicable City requirements and is consistent with the Federal Land Development Guidelines for the Protection of Aquatic Habitat. 2003.

All ESC facilities and works described in the plan must be installed, constructed, and operational in accordance with the approved ESC drawings before any clearing or Construction Works begin.

ESC measures shall be inspected at minimum once a week and before and after every major rainfall. The record of site inspections shall be available to the City upon request.

ESC measures shall not be removed until all disturbed or exposed soil areas are re-vegetated or stabilized.

ESC measures may require modification as development progresses. Modifications shall be approved in advance by the City Engineer.

##### **3.1.3 ESC Plan Requirements**

An erosion and sedimentation control plan must contain sufficient information to describe the site development, the proposed impacts, and the system(s) intended to control erosion and prevent offsite damage / impact from sedimentation. The plan must include:

- .1 Contact information / ownership form and a 24 hour emergency contact phone number for the Professional Engineer and Environmental Monitor responsible for the site;
- .2 A site location map attached with location and width of existing or proposed access(es) to the property;

- 
- .3 Property lines and other legal designations of the subject property with location(s) of any existing/proposed lots, buildings, services, or connections to existing services from the site;
  - .4 Erosion and Sedimentation Control (ESC) details (as noted below) that emphasize use of erosion source control as the primary method for dealing with erosion and sediment runoff. Design specifications for ESC facilities must comply with the requirements of the DFO Land Development Guidelines for the Protection of Aquatic Habitat 2003; and
  - .5 Primary erosion and sediment site source controls including: the location of sediment control ponds that are designed to comply with DFO Site Runoff Water Quality Requirements; location of outfalls and appropriate mitigation controls; proposed contours and drainage flows; Gravel pads at all access points; location of silt fences; location of soil stockpile areas (to be covered up); location of perimeter and infiltration ditches; location of watercourse setback area and watercourses or water bodies; and temporary fencing around designated protection areas.

#### 3.1.4 ESC Best Management Practices

The following is a list of minimum source controls and best management practices required for each site and/or lot where applicable:

- .1 A gravel access pad (4.5 m wide and comprised of a minimum of 6 inches depth and 100 mm diameter angular rock) for each proposed lot at the point of entry onto the lots from the roadway. They shall be constructed and maintained to minimize the migration of sediment onto the roadways.
- .2 Physically mark clearing boundaries on construction sites and ensure temporary fencing is placed around the watercourse protection areas and any designated environmentally sensitive areas or features, as determined by the Professional Engineer or the City of Salmon Arm.
- .3 Install and maintain perimeter ditches, swales, and interceptor ditches on plans that divert runoff away from cleared areas during phased approach and divert runoff into staged primary and auxiliary sediment traps or sediment ponds where appropriate, prior to discharge off site.
- .4 Install and maintain filter fabric bags or equivalent inside any catch basins, on all road frontage catch basins and lawn basins collecting runoff from the construction site.
- .5 Vehicle/machinery access to and from the lot(s) shall be limited to the access pad, staging area, or prepared working road to minimize soil disturbance.
- .6 Roadways (fronting the respective lots) are to be swept free and cleaned on a regular basis (once a day or more frequently during rain events). Flushing of the roadway is prohibited.
- .7 Excavated/imported soils are not to be stockpiled/unloaded on road allowances, curbs, or sidewalks and if soils are stockpiled within the boundary of the lot, then the stockpiles shall be covered with polyethylene sheeting and weighted down. Breaks in the cover should be repaired immediately.

- 
- .8 Sediment laden water that shall be removed by ESC measures, or pumper truck and shall not be released into City Facilities.
  - .9 Temporary graded areas, such as housing lots, must be protected from erosion through the use of straw, mulch and/or polyethylene tarps in non traffic areas and a gravel cap in zones of construction traffic where disturbed soils will be exposed for greater than three (3) months.
  - .10 Final graded or landscaped areas must have the appropriate permanent surface protection or landscaping in place as soon as possible.
  - .11 Where slopes exceed five percent, or where soil types consist predominantly of clays or fines, surface protection must be used from October 15th to May 15th or when rain events are expected.
  - .12 All bare and exposed areas that will be left dormant for longer than three (3) months are to be seeded and stabilized with native vegetative species prior to October 15th where possible.
  - .13 Every construction site where an ESC Plan has been issued must have a waterproof copy of the emergency contact information for the site owner, the designated professional engineer, and the designated contract administrator for the site in a location visible from outside the construction site, for the duration of the construction project.

### **3.2 Site Grading**

#### **3.2.1 Site Grading Plan**

A site grading plan shall illustrate final road and lot grading, lot access locations and grades. Site grading plans shall include, but not be limited to, existing contours, existing/proposed elevations, building envelope with proposed grades, building grades such as minimum/maximum finished floor elevations, lot slopes, location and extent of retaining walls, fencing, swales, control/containment of surface water, seasonal and permanent watercourses, vegetation, top and bottom of bank, bedrock outcroppings, overland flow routes, location and grading of statutory right-of-ways, cut/fill areas, areas of fill that exceed 1.0 meters in depth, limits of engineered fill, safe building setbacks (where required) and any other information as deemed necessary.

#### **3.2.2 Low Points**

Any ultimate low point in the roadway shall have provisions for safe overland flow to protect major flow routes.

#### **3.2.3 Overland flow routes**

Overland flow routes are to be designed as per criteria in Section 7.11 and detailed on the Site Grading Plan.



---

3.2.4 Cut/fill plan

Cut Fill Plan is to be provided prior to the start of earthworks where cuts/fills are over 1.0 meters and on all developments within the Hillside Development Area as defined in Schedule A, Map 1. Large cut/fills to achieve flat yards are discouraged and will not be permitted in developments within the Hillside Development Area.

3.2.5 Slope

Maximum allowable slope shall be 3:1, unless a Geotechnical report prepared by a qualified Professional Engineer has been provided which provides assurance of the slope stability for the proposed grading.

Minimum allowable slope shall be 2.0% for grassed areas and 0.5% for hard surfaces.

3.2.6 Lot Grading Plans

Lots grading plans are required for all development and building permits unless exempted by the City Engineer. Lot grading plans shall detail the location of any development and indicate the type of dwelling if applicable (front walk-out, rear walk-out, etc.). Plans shall thoroughly detail any changes to existing grading both on-site and off-site and any deviations from the approved grading plans. The plan shall provide adequate information to confirm overland flow patterns and routes, building elevation, conformity to City design standards, impacts to adjacent lots, driveway slopes, boulevard slopes, and constructability of lot.

All lots shall be graded to drain away from building foundations. Sheet drainage of runoff onto City property is encouraged (as opposed to point loading).

3.2.7 Swales

Swales along rear, front and side yards shall be used in conjunction with lot grading to protect the subject property from uphill drainage and protect downstream properties from site drainage.

Swales capturing drainage from two or more lots shall be protected by:

- A registered easement in favour of all upstream properties if contributing drainage is from private property.
- A Statutory right-of-way In favour of the City if contributing drainage is from public and private properties or from private properties.

Grass swales shall be graded at a minimum of 1.0%. Concrete swales shall be graded at minimum 0.5%

Swales shall be at a maximum depth of 0.7 meters.

---

### 3.2.8 Retaining Walls

Retaining walls shall be detailed on lot grading drawings with existing and proposed grades and any related cut/fill slopes.

Retaining walls over 1.2 meters (4 feet) in height shall be designed by a professional engineer under City permit.

Private retaining walls shall not be constructed on City Boulevard or statutory right-of-ways.

Retaining walls shall not be used to support public infrastructure where a reasonable alternative exists, unless otherwise approved by the City Engineer.

### 3.2.9 Statutory Right-of-ways

Statutory right-of-way must be graded to provide reasonable access for maintenance equipment.

### 3.2.10 Rough Grading

Rough grading and retaining as detailed on the site grading plan shall be completed by the owner/developer prior to the subdivision approval. Rough grading shall be completed within +/- 100mm of the final approved pre-grade.

## 3.3 **Site Restoration**

### 3.3.1 Restoration of Public Property

All offsite disturbed areas shall be restored to existing condition or better to the satisfaction of the City Engineer.

### 3.3.2 Restoration of Private Property

All disturbed areas on private property shall be restored to existing condition or better to the satisfaction of the property owner. Owner/developer to make all reasonable attempts to obtain written acceptance of restoration from each affected property owner. In the case of a dispute, the City Engineer will have ultimate approval of restoration works.

### 3.3.3 Restoration of Site

Site shall be restored as per the requirements of the approved Erosion and Sediment Control Drawing (refer to Section 3.1), or where there is not an approved Erosion and Sediment Control Plan, landscape as per the requirements in Section 10.0.

## **B. MATERIALS**

Site Preparations and Earthworks materials shall be supplied in accordance with Schedule D – Approved Materials List

---

**C. CONSTRUCTION**

Site Preparation and Earthwork Construction shall be in accordance with Master Municipal Construction Documents (MMCD) Platinum Edition Volume 2 (The MMCD Association, 2009) as amended and Schedule B – Part 3.

**D. TESTING**

Site Preparations and Earthwork Testing shall be in accordance Master Municipal Construction Documents (MMCD) Platinum Edition Volume 2 (The MMCD Association, 2009) as amended and Schedule B – Part 3.

---

## **4.0 ROADS**

### **A. DESIGN CRITERIA**

#### **4.1 General**

Where the provisions of the Subdivision and Development Servicing Bylaw No. 4293 require the construction of roads, the applicant shall construct the roads consistent with the regulations, standards and specifications set out in this schedule.

#### **4.2 Approval Drawings**

Engineering drawings showing detailed design of roads shall be submitted to the City Engineering Department for approval prior to commencement of construction. These drawings shall show existing ground line and proposed alignment and grade of the roads, horizontal and vertical curve information and all other details as may be required. Grades shall be given at all changes in vertical and horizontal alignments for centreline and gutter lines. Elevations shall be shown on the drawings at all changes in vertical alignments and at regular station.

Curb Return profiles required for all radial installations.

#### **4.3 Geotechnical Evaluation**

The applicant shall be responsible for engaging the services of a qualified Geotechnical Engineer to investigate surface and sub-surface conditions within the proposed subdivision/development. The Geotechnical Engineer shall prepare a report outlining his finds and shall provide clear, definitive recommendations on the geometry and placement of fill sections, compaction requirements over and above those stipulated in this bylaw, cut slope geometry, pavement structures for roads, and any other geotechnical issues affecting road construction within the proposed subdivision/development.

#### **4.4 Road Classification**

The roads shall be designed in accordance with the road classification specified by the City of Salmon Arm in the Letter of Preliminary Subdivision Review and shall conform to the provisions of the City of Salmon Arm 'Official Community Plan'.

#### **4.5 Design Speed**

Design speeds shall be as listed below unless otherwise approved by the City Engineer.

Major Local Roadway	50 km/h	(Directly connects to a Connector Road)
Minor Local Roadway	40 km/h	(Connects to Local Roads only or cul-de-sacs)
Town Centre	40 km/h	
Industrial Roadway	50 km/h	
Collector Roadway	70 km/h	
Arterial Roadway	80 km/h	
Hillside Local	30 km/h	
Hillside Collector	50 km/h	
Hillside Arterial	60 km/h	

---

## **4.6 Right of Way Widths**

### **4.6.1 Standard Right-of-way Widths**

Right of way width will be as noted in the applicable roadway cross-section

### **4.6.2 Additional Right-of-way Width**

Additional width may be required where necessary to permit turn lanes, roundabouts, bike lanes, or pathways.

### **4.6.3 Reduced Right of Way widths**

Reduced Right of Way widths may be considered where one or many of the following conditions exist:

Adjacent constraints such as CPR right of way or Indian Reserve;

Cul-de-sacs or other low volume roadways;

Historical reductions existing along roadways (variances); or

Where there will be future dedication on adjacent property.

### **4.6.4 Corner Cuts**

Corner cuts are required to be 3.0 meters x 3.0 meters on local streets and 5.0 meters x 5.0 meters on collector and arterial streets, at all street intersections. Additional dedication may be required to accommodate a Round-about.

## **4.7 Lanes**

New lanes are discouraged, but may be permitted under special circumstances with approval from the City Engineer. Lanes within existing rights-of-way shall conform to Specification Drawing No. RD-12a. New lanes shall conform to Specification Drawing No. RD-12b.

## **4.8 Cross-Sectional Elements**

### **4.8.1 Road Cross-Section**

Roads shall be constructed to the dimensions specified on Specifications Drawings No. RD-1 through RD-16.

### **4.8.2 Road Structure**

The road structures indicated on Specification Drawings No. RD-1 through RD-16 is the minimum acceptable road structure.

A Professional Engineer, registered in the Province of British Columbia, shall confirm that the road structure indicated on the specification drawings is capable of supporting the proposed loading for a 25 year lifespan, or recommend a more stringent road structure where conditions warrant.

Minimum cross slope of installed gravels shall be 3.0% unless otherwise approved by the City Engineer.

---

Base gravels shall daylight on all roadways without a municipal storm system or subdrains shall be provided. Where a low point exists on a roadway, subdrains shall be installed for a minimum 5m distance upstream and be connected into the low point catchbasins to allow proper drainage of base gravels into the municipal stormwater system. In other cases, subdrains may be required by the City Engineer in addition to the municipal storm system, where adverse geotechnical conditions warrant the installation.

#### 4.8.3 Boulevards

Boulevards are to be graded towards the street line including any driveway entrances, or hydraulic capacity calculations for the roadway will be required.

When Boulevard landscaping and irrigation is required the owner/developer shall prepare a landscaping and irrigation design drawing, in accordance with Section 10.0.

#### 4.8.4 Bike lanes

Bike lanes shall be provided in locations noted in the City of Salmon Arm 'Official Community Plan' and shall be constructed to the specifications indicated on the applicable Road Cross-Section design drawing.

#### 4.8.5 Ditches

Ditches shall be required on all high sides of Rural Roads and shall be of appropriate depth to drain the roadway base. Ditches may be required on the low side of rural roadways where roadway base drainage cannot be accommodated with existing topography.

Sheet drainage is preferred; point source loading may be permitted when outlets into an approved existing drainage route.

Ditches shall be vegetated or otherwise protected from erosion. Refer to Section 3.1.

#### 4.8.6 Curb and Gutter

Concrete Curb & Gutter shall be constructed in accordance with the cross-sections illustrated on Specification Drawings CGS-1, CGS-2 and CGS-3, for the applicable road cross-section.

#### 4.8.7 Sidewalks and Multi-use Paths

Concrete sidewalks shall be constructed in accordance with Specification Drawings No. CGS-4a and CGS-4b and shall be designed using best practices meeting the specifications outlined in the latest edition of the British Columbia Active Transportation Design Guide where possible.

Let downs shall be constructed as per CGS-5 and CGS-6.

Sidewalk shall be 150mm thick in all residential areas and 180mm thick in all commercial areas.

Multi-Use Paths to be constructed in accordance with Specification Drawing No. CGS-8.

The maximum and minimum grades for sidewalks and multi-use paths shall not exceed the maximum and minimum road grades.

---

Sidewalks and multi-use paths and adjacent appurtenances must be designed and constructed to permit snow clearing equipment to pass through uninhibited.

#### 4.8.8 Walkways

Concrete walkways shall be constructed in accordance with Specification Drawings No. CGS-7.

Walkway let downs shall be constructed in accordance with Specification Drawing CGS-6 and provided at all road intersections, walkways and mailbox locations.

The maximum grade for walkways shall be 15%. Although discouraged, concrete stairs may be considered where walkways must exceed 15% as approved by the City Engineer. Refer to Section 4.8.10.

Where a change in direction occurs in a walkway, provisions must be made in the design and construction to permit snow clearing equipment to pass through uninhibited.

#### 4.8.9 Crosswalks

Crosswalks within the Town Centre Development Area shall be thermoplastic crosswalk surfaces in accordance with the approved materials list.

#### 4.8.10 Stairs

Prior to authorizations of concrete stairs, alternate walk routes must be submitted for city review and approval. Only where other acceptable walk routes are not available, will the installation of stairs be considered. In all cases, concrete stairs must conform to B.C. Building Code and in accordance with Specification Drawing No. RS-1 and RS-2. Advance warning signage shall be placed at both ends of stairways.

Stairway landings shall not exceed 2% grade in any direction.

Handrails shall be installed on the concrete stairs in accordance with Specification Drawings RS-1 and RS-2.

#### 4.8.11 Pathways and Trails

Pathways and Trails are to be dedicated and installed at the direction of the City Engineer in locations identified in the Official Community Plan. The exact location shall be negotiated through the detailed design process. Trail type to be specified and constructed in accordance with Greenways Strategy “Weave it Green”. Pathways and Trails shall be constructed in accordance with Specification Drawings No. CGS-8 through CGS-12.

The maximum grade for pathways shall be 20%. Prior to the authorization of stairs, alternate walk routes must be submitted for City review and approval. Only where other acceptable walk routes are not available, will the installation of stairs be considered. In all cases, stairs must be built to B.C. Building Code. Refer to Section 4.8.10.

#### 4.8.12 Canada Post Boxes

Location of Canada Post mailboxes shall be shown on the design drawings as confirmed with Canada Post and be acceptable to the City Engineer.

Mailboxes locations shall be located in the boulevard adjacent to side lots, have sidewalk access and be in well lit areas, where possible.

**4.8.13 Transit Bays**

Transit bays shall be constructed at locations determined by the City Engineer. Specifications are available upon request.

**4.8.14 Parking Bays**

Parking bays are required on Urban Collector Roads where adjacent to medium and high density residential, Institutional or Commercial zoned properties in accordance with Specification Drawing RD-3.

**4.8.15 Sign Post Bases**

Sign Post Bases shall be installed in accordance with Specification Drawing SP-1.

**4.9 Alignment Elements**

The design of road (vertical and horizontal) alignments shall be in accordance with the Transportation Association of Canada manuals; Geometric Design Guide for Canadian Roads and Urban Supplement to the Geometric Design Guide for Canadian Roads, as amended. Where there is a discrepancy between the guidelines and the parameters below, the bylaw value shall be used unless otherwise approved by the City Engineer:

Design Parameter	Design Speed (Km/h)					
	30	40	50	60	70	80
Minimum Radii 2% Super El.	30	65	115	185	290	400
	4% Super El.	20	45	80	130	200
	6% Super El.	-	-	-	-	250
Maximum Superelevation	4%	4%	4%	4%	4%	6%
Minimum Gutter Grade	0.7%	0.7%	0.7%	0.7%	0.7%	0.7%
Minimum Centreline Grade	0.5%	0.5%	0.5%	0.5%	0.5%	0.5%
Maximum Centreline Grade	12.0%	12%*	12%**	10.0%	10.0%	8.0%
Maximum cul-de-sac grade	6%	6%	6%	6%	6%	6%
Minimum Crest (K) ***	2	4	7	15	22	35
Minimum Sag (K)***	4	7	11	20	25	30

\* 6% Town Centre

\*\* 8% Industrial

\*\*\* May be reduced approaching a stopped condition

**4.9.1 Cross Slopes**

Cross slopes shall be 2.0%, except at intersection and horizontal curves where approved by the City Engineer.



---

## 4.10 Intersection Design

### 4.10.1 Round-Abouts

The use of a round-about is encouraged over the use of a stop-controlled intersection or traffic lights. A round-about shall be designed using best engineering practice. A conceptual design shall be submitted to the City along with a design brief for approval prior to commencing detailed design.

### 4.10.2 Maximum Grade

The maximum grade for minor roads entering an intersection shall be +/-2% for a distance of 15 metres from the edge of pavement to the point of intersection of the vertical curve (without a stop condition) or +/- 3% for a distance of 15 metres from the stop bar to the point of intersection of the vertical curve.

### 4.10.3 Angle

Intersections shall meet substantially at right angles (between 70 degrees and 110 degrees)

### 4.10.4 Curb Returns

The following minimum curb return radii shall apply:

Road Classification	Specification Drawing	Curb Return Radii
18 m R/W Urban	RD-1	7.5 m
20 m R/W Urban	RD-2	7.5 m
20 m R/W Collector	RD-3	11.0 m
25 m R/W Arterial	RD-4	11.0 m
20 m R/W Rural	RD-5	13.0 m

Curb return design information is required to be shown on design drawings (i.e. gutter grades and elevations, direction of drainage, etc.). Curb returns shall be designed to avoid conflict with wheel paths, utility manholes, water valves, street lights, power poles, etc.

## 4.11 Cul-De-Sacs

### 4.11.1 General

Cul-de-sac streets should be avoided unless topographic or surrounding land constraints make continuation or projection of conventional roadways impractical.

### 4.11.2 Grading

Cul-de-sac design shall conform to Specification Drawing No. RD-10 and RD-11. Cul-de-sacs should be graded towards the street where possible or designed such that surface drainage has a suitable overland flow route.

### 4.11.3 Driveways

Driveways on cul-de-sacs shall be 4.0m wide, within City Right-of-Way as measured along property line unless adequate snow storage can otherwise be provided. Driveway locations shall be shown on design drawings. Driveways shall be paired at property lines.

---

A statutory Right-of-way may be required to accommodate snow storage where space is limited.

#### 4.11.4 Length

Cul-de-sac dead end roads shall not exceed 160 meters in length in Urban, Town Centre and Industrial Development Areas and 300 meters in length in Rural Development Areas. The measured length shall be along centreline from the centre of the first intersection having access from two alternate routes to the centre of the cul-de-sac. At the discretion of the City Engineer, a 'T' Turn Around (Specification Drawing No. RD-13) may be permitted for lanes and temporary dead ends for streets where subdivision/development is phased; however, provision must be made for snow storage.

#### 4.12 **Pavement Marking and Signage**

A Pavement Marking and Signage drawing shall be provided with the design drawings.

Regulatory and information signs and pavement markings shall be supplied and installed in accordance with the latest version of the City of Salmon Arm's Pavement Marking and Signage Plan and as per TAC guidelines at the owners/developers full cost.

Sign Post Bases shall be in accordance with Specification Drawing No. SP-1.

#### 4.13 **Access**

##### 4.13.1 Driveways

Standard driveway widths shall be 6.0m for residential and 8.0m for commercial developments. Maximum driveway widths shall be 8.0m for residential and 10.0m for commercial developments, where frontage widths are at minimum twice the driveway width and at the discretion of the City Engineer.

All driveway let downs where a sidewalk or multi-use path exists along the frontage shall be constructed as per Specification Drawing CGS-5.

A minimum clearance of 0.5m is required from the edge of asphalt to any infrastructure such as hydrants, light posts and transformers. Clearance to third party utility infrastructure such as transformers shall be confirmed with the applicable utility.

##### 4.13.2 Combined/Shared Access

Subdivision or development shall be designed by keeping to a minimum the number of access driveways connecting directly to an Arterial or Collector Street. Where driveways can be located onto local roadways no accesses on to Arterial or Collector Streets will be permitted.

Where possible, except in Rural areas, properties fronting Arterial or Collector Streets shall have shared driveway access.

##### 4.13.3 Number of Accesses

Only one access will be permitted for each single family residential, duplex or medium density lot.

---

An additional access may be considered, at the discretion of the City Engineer, where the subject lot is a corner lot or where the street frontage is twice or greater the minimum frontage as specified in the Zoning Bylaw and where no safety issues are created. Multiple accesses may be considered for industrial, commercial, agricultural and high density lots, provided the distance between accesses is greater than 10 meters and there are no safety issues created.

4.13.4 Clearance to Intersection

Residential access locations shall be greater than 5.0 meters from an intersection, as measured from the ultimate property line closest to the intersection.

Industrial, commercial, agricultural, medium and high density access locations shall be greater than 12.0 meters from an intersection, as measured from ultimate property line closest to the intersection.

4.13.5 Servicing Conflicts

Lot Services and other above ground appurtenances shall be located outside of accesses unless otherwise approved by the City Engineer. Where services are allowed within the access, protection shall be provided in the form of concrete utility box.

4.13.6 Grade

The maximum grade for a lot access shall be 15% for a maximum distance of 25 meters as measured from the building. Access greater than 25 meters from the building to the edge of right of way shall conform to City of Salmon Arm Policy 3.11 and shall ensure the first 3.5m of the driveway has a grade of no greater than 7.0%. In all cases, boulevard grading shall conform to standard drawings. Designers shall ensure grade transitions on driveways account for vehicle clearance.

**B. MATERIALS**

Roads materials shall be supplied in accordance with Schedule D – Approved Materials List.

**C. CONSTRUCTION**

Roads construction shall be in accordance with Master Municipal Construction Documents (MMCD) Platinum Edition Volume 2 (The MMCD Association, 2009) as amended and Schedule B – Part 3.

**D. TESTING**

Roads testing shall be in accordance with Master Municipal Construction Documents (MMCD) Platinum Edition Volume 2 (The MMCD Association, 2009) as amended and Schedule B – Part 3.

---

## **5.0 WATER SYSTEMS**

### **A. DESIGN CRITERIA**

#### **5.1 General**

##### **5.1.1 Water for Domestic Purpose**

In any subdivision and/or development, a source of water for domestic purpose shall be available on each parcel, except where the intended use of the parcel does not require a supply of water for domestic purpose and the owner/developer grants a covenant in favour of the City of Salmon Arm at the time of subdivision, such covenant to limit the use of land within the parcel.

For the purpose of this subsection “Water for Domestic Purpose” means water which (subject to such approvals as may be required in accordance with the Public Health Act) is intended for use for household requirements including but not limited to the normal household requirements of sanitation, human consumption and food preparation, fire prevention and watering of domestic animals and poultry.

##### **5.1.2 Municipal or Alternative Water Source**

Where connection to the City’s water distribution is required, connection shall be provided in accordance with Sections 5.3.

Where connection to the City’s water system is not required by this bylaw, all parcels within a subdivision or development shall have an on-site potable source of groundwater or surface water available for domestic purpose in accordance with Section 5.2.

##### **5.1.3 Extension of Water Distribution System**

Where the provisions of the Subdivisions and Development Servicing Bylaw No. 4293 require the construction of a water distribution system, the applicant shall provide a water distribution system and storage facilities including watermain, valves, hydrants, service connections, pump stations and reservoirs consistent with the regulations, standards and specifications set out in this schedule. All standards not specifically described in this schedule shall be in accordance with appropriate American Water Works Association (AWWA) standards or as directed by the City Engineer.

#### **5.2 Alternative Water Source**

Where a City water distribution system is not available and installation of a new on-site water supply system is required, either a Professional Driven Approach (completed by a qualified Professional Engineer) or a Homeowner Driven Approach (completed by the homeowner and/or qualified well driller) may be required to certify quality and quantity of the alternative water source as described below.

Where installation of a new well is not required, homeowner to provide proof of water quality from within the previous twelve (12) months.

Where a significant change in density on the parcel is proposed through re-zoning, the City Engineer may require a quantity test to be completed on an existing well.

---

5.2.1 Alternative Water Source Approval for Subdivision or Development

The Professional Driven Approach shall be used if any of the following is true, and the owner/developer must provide to the City the information that is required to enable the City to make that determination:

- The proposed subdivision will result in two or more additional parcels;
- The proposed parcels are each less than two (2) hectares in area;
- The proposed subdivision is not located within an area indicated as being within a known aquifer, as identified on BC Water Resources Atlas interactive mapping tool (as revised - <https://maps.gov.bc.ca/ess/hm/wrbc/>);
- The proposed subdivision is located within an area of concern for groundwater issues as identified on BC Water Resources Atlas interactive mapping tool (as revised - <https://maps.gov.bc.ca/ess/hm/wrbc/>);
- Proposed groundwater source is within 30 meters of any other existing groundwater source or source of potential contamination;
- The proposed water source is surface water;
- The proposed water source is a shallow well that the owner intended to install without hiring a Qualified Well Driller or a Qualified Pump Installer;
- Prior to commencing construction or testing, the Qualified Well Driller or Qualified Pump Installer engaged to provide a Well has provided an opinion, having been requested by the owner/developer to consider the matter, that drawdown interference, or water quality issues are likely to occur based on their personal knowledge of the area in which the Well is proposed; or
- The City has requested a review of the information provided, as required above, by a Qualified Registered Professional, and that professional recommends a professional directed approach.

5.2.2 Professional Driven Approach (Groundwater)

A qualified professional shall perform or oversee a well test and Proof of Source Yield for each lot shall be provided as per the requirements in Section 5.2.7. Well logs shall be submitted to the Groundwater Protection Officer and the City. A representative number of well tests may be accepted on multiple lot subdivisions (three (3) or more) based on professional recommendations; however, in no case shall the tests be on less than 25% of the lots.

A qualified professional shall sample the well water and submit a sample to an authorized water testing laboratory for analysis of water quality as per the requirements in Section 5.2.5. Results shall be submitted to the Groundwater Protection Officer and the City.

Failed quality tests require sign off from a professional that treatment can be achieved to make water potable using readily available treatment methods.

---

Where treatment is required, a covenant shall be placed on the property as per the requirements in Section 5.2.6.

A report shall be provided conforming to the Guide to Conducting Well Pumping Tests (Ministry of the Environment), The report must be submitted by a groundwater geologist or professional engineer (whose field of competence lies within the groundwater fields), and indicate factors leading to the conclusion that the required supply of potable groundwater will be available for the foreseeable future giving due consideration to the possible interference with septic tanks, neighbouring wells, the effect on the aquifer of simultaneous pumping from other wells, and the seasonal fluctuation in ground water levels.

### 5.2.3 Homeowner Driven Approach (Groundwater)

A qualified well driller or qualified pump installer shall perform a well test and provide Proof of Source Yield as per the requirements in Section 5.2.7. Well logs shall be submitted to the Groundwater Protection Officer and the City.

A qualified well driller or qualified pump installer shall sample the well water and submit a sample to an authorized water testing laboratory for analysis of water quality as per the requirements in Section 5.2.5. Results shall be submitted to the Groundwater Protection Officer and the City.

Failed quality tests require sign off from a professional that treatment can be achieved to make water potable using readily available treatment methods.

Where treatment is required, a covenant shall be placed on the property as per the requirements in Section 5.2.6.

Mapping shall be provided indicating the location of the well within each property and proximity to any other water sources or potential contamination sites (septic tanks, etc.).

### 5.2.4 Surface Water

Proof of Source Yield shall be provided as per the requirements in Section 5.2.8.

A water quality test shall be completed as per the requirements in Section 5.2.5.

Failed quality tests require sign off from a professional that treatment can be achieved to make water potable using readily available treatment methods.

Where treatment is required, a covenant shall be registered on title as per the requirements in Section 5.2.6.

---

5.2.5 Water Quality Testing

Where water quality testing is required for approvals the water must be tested and proven safe for human consumption. The certification must clearly state whether or not the water tested meets the limits imposed by the Canadian Drinking Water Guidelines (Current Edition) standards for the following parameters: alkalinity, Arsenic, Calcium, Chloride, Colour, Conductivity, Fluoride, Hardness (total), Iron, Magnesium, Manganese, Nitrate, Nitrite, pH, Potassium, Silicon, Sodium, Sulphate, Total Dissolved Solids, Turbidity, Uranium, Total Coli form, Fecal Coli form.

5.2.6 Covenant

Where a covenant is required for approvals, the owner/developer must register on title of each lot serviced by an alternate water source a covenant in favour of the City of Salmon Arm relative to the required engineered treatment system necessary for any future development. The form of the covenant shall be approved by the Approving Officer and City Engineer.

5.2.7 Proof of Source Yield (Groundwater)

Where proof of groundwater source yield is required for approval, proof that a supply of potable water for domestic purpose is available of not less than 9 litres (1.98 gallons) per minute for a period of 4 hours and with a sustained yield of not less than 2,250 litres (495 gallons) per day for a single family dwelling on a year round basis is available to each parcel shall be provided to the City in the form of a well test.

Well tests shall be conducted in accordance with the Guidelines of Minimum Standards in water Well Construction, Province of British Columbia ISBN 0-7719-8987-3 including well testing certification in accordance with Schedule C, Form F-7

5.2.8 Proof of Source Yield (Surface Water)

Where proof of surface water source yield is required for approval, proof that a supply of potable water for domestic purpose is available with a sustained yield of not less than 2,250 litres (495 gallons) per day for a single family dwelling on a year round basis is available to each parcel in the form of surface water shall provide the City with:

- A water licence from the relevant provincial authority having jurisdiction for each parcel created by subdivision or development; or
- A letter signed by the relevant provincial authority having jurisdiction acknowledging that a water licence will be issued to each parcel being created by the subdivision application upon completion of the subdivision registration; and
- Evidence that the parcel owner will have legal access to the water source via an easement on private lands or a permit on Crown land where the surface water licence is not on the parcel being serviced

---

### 5.2.9 Water Treatment

Surface waters and/or ground water influenced by surface water will require treatment that will provide a minimum 3 log reduction (99.9%) of Giardia cysts. Additional treatment may be required for high risk water supplies. The Covenant referenced in Section 5.2.6 shall reflect the requirement for an engineered treatment system.

Where water quality tests fail in relation to a proposed subdivision, the subdivision shall not be approved unless a qualified professional has provided assurance that treatment can be achieved to make water potable using readily available treatment methods. The Covenant referenced in Section 5.2.6 shall reflect the requirement for an engineered treatment system.

Where treatment is required in relation to a proposed development, an occupancy permit shall not be issued unless an engineered treatment system has been installed and tested. A water sample shall be taken from the development upon installation of the engineered treatment system and sent for Water Quality Testing (Refer to Section 5.2.5).

## 5.3 **Municipal Water Source**

No construction shall commence until engineering drawings have been approved by the City Engineer and Ministry of Health.

### 5.3.1 City of Salmon Arm

Engineering Drawings showing detailed design of the necessary works shall be submitted to the City Engineer for approval.

These drawings shall show alignment, size, grade, class and depths of pipes, pipe bedding requirements, existing ground line and proposed final ground line over the pipe, location, elevation and detail of all fittings, valves and hydrants, location of all service connections, location, access to, size and details of any pump stations and reservoirs, all easements and all such other details as may be required. Where a water system is not yet available, rights of ways may be required to be provided by the applicant to allow for the eventual installation of this facility. Such rights of ways shall be registered in favour of the City of Salmon Arm at the applicant's expense.

### 5.3.2 Interior Health Authority

The watermain design shall conform to the requirements of Interior Health Authority (IHA).

The owner/developer shall submit a set of the water utility drawings to IHA for a permit issued under Section 7 of the BC Drinking Water Protection Act authorizing construction of the waterworks. The original permit shall be submitted to City Engineer prior to commencing construction.



## 5.4 Main Sizing

### 5.4.1 Pipe Flow Formula

Water mains shall be designed using a proven network analysis computer model based on the Hazen-Williams Formula,

$$Q = \frac{CD^{2.63}S^{0.54}}{278780}$$

Where,            Q = rate of flow in litres/second  
                       D = internal pipe diameter in mm  
                       S – Slope of hydraulic grade line in m/m  
                       C = Roughness coefficient

### 5.4.2 Minimum watermain sizes

The minimum watermain sizes are as follows:

Residential (Low and Medium Density)	150mm
Commercial, High Density Residential, Institutional	200mm
Industrial	250mm

Density shall be based on current Zoning or OCP designation, whichever is higher.

Where no further extensions are possible, watermain 100mm in diameter may be installed for domestic service on cul-de-sac roads beyond the last hydrant.

### 5.4.3 Design velocity

Design velocity shall not exceed 0.60 m/sec for Average Day Demand and 3.65 m/sec for Maximum Day Demand plus Fire Flow or Peak Hour Demand, whichever is greater.

### 5.4.4 Per Capita Demand

Watermain sizing design flows are as follows:

Average Day Demand	900 litres/day/capita
Maximum Day Demand	2,000 litres/day/capita
Peak Hour Demand	3,600 litres/day/capita

### 5.4.5 Non-Residential Demand

Equivalent Populations for non-residential demands are as follows:

Commercial	90 people/ha
Institutional	50 people/ha
Industrial	90 people/ha

**5.4.6 Fire Flow Requirements**

The following fire flows must be met for the noted zones and development:

Rural Areas	30 litres/sec
Low Density (Single Family Dwelling / Mobile Home Parks / Duplex)	60 litres/sec
Medium Density (Triplex / Fourplex)	90 litres/sec
Commercial / Institutional / Apartments	150 litres/sec
Industrial	225 litres/sec

**5.4.7 Design Flows**

Total design flows are to be the greater of the Maximum Day Demand for the population or equivalent population plus the Fire Flow, or Peak Hour Demand for the population or equivalent population.

**5.4.8 Design Pressures**

Watermain pipe shall be designed to accommodate 1.5 times the maximum projected working pressure for the applicable pressure zone. Pressure zones shall generally be set at minimum pressure of 250kPa under peak hour conditions and a maximum pressure of 790kPa under static conditions. Pipe specification and material shall be noted on the drawings.

Minimum service pressures during Maximum Day Demand plus fire flow shall be as follows:

Peak Hour	250kPa (40 psi)
Maximum Day Plus Fire Flow	Hydrant Pressure System Pressure
	150kPa (20 psi) 150kPa (20 psi)

**5.5 Vertical Alignment**

**5.5.1 Grade**

Watermain shall be installed at a minimum grade of 0.1%. Maximum grade shall be 20%. Exceptions may be granted by the City Engineer where grades in excess of 20% have been reviewed for trench dam and joint restraint requirements.

**5.5.2 Chambers**

Chambers or manholes containing valves, blow-offs, meters, or other appurtenances should allow adequate room for maintenance, including headroom and side room and shall be a minimum 1050mm precast concrete. Access openings must be suitable for removing valves and equipment. The chamber is to be provided with a drain to a storm sewer or ditch, complete with backflow prevention, to prevent flooding of the chamber. Rock pits may be considered subject to suitable soil and groundwater conditions.

Insulation to prevent freezing should be provided where necessary.

---

### 5.5.3 High Points

Watermain shall be designed with a rising grade wherever possible to minimize high points in the main. Where a high point is unavoidable, either a service or air release valve shall be installed at that point.

### 5.5.4 Air Release and Vacuum Valve

Air Release and Vacuum Valves shall be installed at the high points in all watermain installations except where:

- the difference in elevation between the summit and valley is less than 600mm;
- it can be shown that air pockets will be carried by typical flows
- active service connections are suitably located to dissipate entrapped air.

For 100mm – 500mm watermain refer to Specification Drawings No. W-6, for 600mm – 1200mm watermain refer to Specification Drawing No. W-7.

Air valves must be vented to an appropriate above-grade location to eliminate any potential for cross connection in a flooded or contaminated chamber and shall be located within the sidewalk or boulevard.

### 5.5.5 Depth of Cover

The minimum pipe cover, from finished grade to top of pipe shall be 1.8 meters.

### 5.5.6 Vertical Clearance

The vertical clearance from bottom of watermain to top of sewer shall be the greater of 0.3m or the minimum clearance as set out in IHA's "Guidelines for the Construction of Waterworks". Actual clearance shall be labelled on approved design drawings.

Where the vertical clearance cannot be achieved, reduced clearance may be permitted where joints are wrapped with heat shrink plastic or packed with compound and wrapped with petrolatum tape in accordance with the latest version of AWWA Standards C217, and C214 or C209, as approved by IHA.

## 5.6 **Horizontal Alignment**

### 5.6.1 Location in Roadway

Watermain shall be aligned in accordance with those indicated on the Road Cross Section Specification Drawings.

### 5.6.2 Horizontal Curves

Horizontal curves in watermain will not be permitted, unless otherwise approved by the City Engineer. If horizontal curves are approved, they shall be uniform throughout the curve. The radius of the curvature shall not be less than 50 meters. The deflection in all cases must not exceed 50% of the manufacturer's recommendations for maximum deflection, unless otherwise directed by the City Engineer. Five (5) degree pre-manufactured bends to the same standards as the mainline pipe may be utilized to achieve the design radius.

---

### 5.6.3 Horizontal Clearance

The horizontal clearance shall be the greater of 3.0m or the minimum clearance as set out in IHA's "Guidelines for the Construction of Waterworks". Actual clearance shall be labelled on approved design drawings.

Where the horizontal clearance cannot be achieved, reduced clearance may be permitted where joints are wrapped with heat shrink plastic or packed with compound and wrapped with petrolatum tape in accordance with the latest version of AWWA Standards C217, and C214 or C209, as approved by IHA.

### 5.6.4 Chambers

Chamber lids locations shall not conflict with curbs, gutters or sidewalks and where possible and shall be located outside of the wheel path of normal traffic flow.

### 5.6.5 Main Looping

Watermain shall be looped or interconnected at a maximum of 200 meter intervals. Provision shall be made for future looping, where required by the City Engineer.

### 5.6.6 Dead End Watermain

Dead end watermain shall be avoided wherever possible. If not possible a blow off assembly shall be provided in accordance with Specification Drawing No. W-4.

## 5.7 **Main Line Valve Size and Locations**

Main line valves shall be the same diameter as the main line pipe and shall be located in the following locations (subject to Engineering/Operational review):

- three (3) valves required at a cross (+) fitting;
- two (2) valves located at a tee (T) fitting;
- As necessary to ensure maximum spacing of 200 meters.
- As necessary so that no more than 20 service connections are isolated at one time;
- As necessary so that no more than one (1) fire hydrant is out of service at any one time;
- On each end of a statutory right of way; and,
- On each side of a major crossing such as under the Salmon River, TCH or Canadian Pacific Railway.

---

## **5.8 Fire Hydrants**

### **5.8.1 Spacing**

For developments, additional fire hydrants shall be located and spaced in accordance with the requirements of the British Columbia Building Code and the City of Salmon Arm Fire Department.

For subdivision and developments, fire hydrant spacing shall be approximately, and in all cases shall not exceed 150 meters in low density residential zones and 90 meters in medium and high density residential zones, commercial, industrial and institutional zones and 300 meters in ALR/Rural zones.

The calculation for fire hydrant spacing and the distance to the principle entrance of a building shall be measured along centreline of the fronting road and shall not be separated by a controlled access highway for commercial, industrial or institutional zoned land.

### **5.8.2 Location/Clearance**

Fire hydrants shall be installed at property lines in mid-block locations and at intersections wherever possible.

Fire hydrants shall be located at minimum 2.0m from back of curb or 0.5m from back of sidewalk.

A 1.0 meter radius clearance, free of obstructions must be provided around all fire hydrants.

Where a fire hydrant requires to be installed behind a ditch, a 1.0 meter radius paved clearance must be provided around the fire hydrant, and a 6.0 meter culvert installed.

### **5.8.3 Connections**

Fire Hydrant connections shall be a minimum of 150mm in diameter.

### **5.8.4 Depth of Cover**

Minimum depth of cover shall be 1.8 metres. Where extra depth is required for the hydrant connection, the compression fitting shall be installed at 1.8 vertical metres and all required extensions shall be installed beneath the compression fitting.

## **5.9 Thrust Blocks and Joint Restraints**

Thrust blocks and/or adequate joint restraining devices must be provided at bends, tees, wyes, reducers, plugs, caps, valves, hydrants and blow offs. They shall be designed for a minimum 1725kPa water pressure. Refer to Specification Drawing No. W-1. Bends at 5 degrees must be in accordance to the manufactures specifications. Engineered calculations shall be provided to the City Engineer, when required, for all thrust block design based on fitting type, water pressure and soil conditions.

Precast thrust blocks will be permitted when approved by the City Engineer.

The restraint system must take into account potential future excavations in the vicinity of the water main.

---

## 5.10 Water Services

All connections/disconnections to the City water infrastructure shall be in accordance with the Waterworks and Water Supply Bylaw No. 1274

### 5.10.1 Number of Connections

Only one water service connection will be permitted per legal lot, including single family residential, multi-family sites, mobile home parks, institutional, commercial and industrial developments, except the owner/developer may provide separate water services to each single family unit that is developed in accordance with the Strata Property Act provided all units in the development are ground-oriented. Strata developments and other major developments will be permitted only one (1) connection unless otherwise approved by the City Engineer where site conditions warrant additional connections, fire flow requirements or where a single service is not practical.

### 5.10.2 Diameter

New water services to single family dwellings shall be no less than 25mm in diameter, installed and located in accordance with Specification Drawings No. W-2 and SER-1. During development, existing water services under the minimum diameter may remain if the service has sufficient capacity for the proposed development and the service is under 25 years old with the approval of the City Engineer.

Water services to all other developments shall be sized in accordance with the current editions of the British Columbia Building Code.

Water service connections for fire hydrants, sprinklers or other fire control facilities shall be sized appropriately. The designer shall ensure the existing municipal water distribution system is adequate under maximum day demand for the flow and residential pressure desired at the point of connection.

### 5.10.3 Minimum Pressure

Minimum residential water service working pressure during peak hour conditions shall be 210kPa at an elevation of 6.1 meters above the footing elevation at the building site.

### 5.10.4 Pressure Reducing Valves

Services shall be protected with a pressure reducing valve at the structure on private property.

### 5.10.5 Curb Stop Location

The curb stop at the end of each service pipe must be located 300mm from the property line, on the road right of way, and at the centre of each lot. Where such locations will conflict with other services, the location may be revised with the approval of the City Engineer. Where curb stops are located within driveways, or behind roll-over curb they shall be protected using a concrete utility box.

### 5.10.6 Tracer wire

Tracer wire shall be installed with all water services.

## **5.11 Water Meters**

### **5.11.1 Water Meters**

Water meters are required for all developments (including single family and duplex dwellings). One meter per water service connection will be permitted except as noted below in Section 5.11.2. Refer to Specification Drawings No. W-10, W-11 and W-12.

All domestic water and irrigation water use are to be metered. Water for fire hydrants, sprinklers or other fire control facilities does not require metering.

The City will supply all water meters, complete with remote reader and strainer at the full cost of the owner/developer.

### **5.11.2 Credit Meters**

Except in parcels zoned R-1, R-2, R-3, R-7, R-8 or R9, the City will permit the installation of an irrigation credit meter at the owners/developers cost to assist with the sanitary sewerage user fees.

### **5.11.3 Meter Vaults**

Where there is more than one (1) dwelling per legal lot and/or the length of service is greater than 25 meters, or in other site specific cases as determined by the City Engineer, a meter vault will be required on the owner/developer's property within one (1) meter of property line (owner/developer to monitor). Installation shall be in accordance with Specification Drawing No. W-12.

## **5.12 Valve Box Marker**

In Rural areas only, a valve box marker shall be installed for all main line valves. Refer to Specification Drawing No. W-5.

## **5.13 Pump Stations Control Valves and Reservoirs**

City will directly retain consultants for the design and construction supervision of new or modifications to existing pump stations, reservoirs, control valves and metering stations and electrical and SCADA controls for the City's water utilities.

## **5.14 Corrosion Protection**

Where there is a potential for encountering corrosive soils, a geotechnical corrosion analysis on the alignment of any proposed metallic watermain and appurtenances should be conducted to determine the corrosiveness of the native soils. If the soils are determined to be corrosive, measures such as cathodic protection should be included to prevent the corrosion of the watermain and appurtenances.

**5.15 Cross Connection Control**

There shall be no connection permitted between a public water system and a private water system without approved backflow prevention.

All new buildings, irrigation systems, and municipal piping systems must be protected from backflow and in accordance with the BC Building Code, the Canadian Standards Association B64.10.07 or most current editions and the requirements of the city of Salmon Arm's Cross Connection Control Bylaw 3934.

**5.16 Abandonment of Mains**

Abandoned sections of utilities shall be removed in accordance with appropriate procedures unless otherwise approved by the City.

**B. MATERIALS**

Water system materials shall be supplied in accordance with Schedule D – Approved Materials List.

**C. INSTALLATION**

Water system materials shall be supplied in accordance with Master Municipal Construction Documents (MMCD) Platinum Edition Volume 2 (The MMCD Association, 2009) as amended and Schedule B – Part 3.

**D. CLEANING, FLUSHING, DISINFECTING AND TESTING**

Water system cleaning, flushing, disinfecting and testing shall be in accordance with Master Municipal Construction Documents (MMCD) Platinum Edition Volume 2 (The MMCD Association, 2009) as amended and Schedule B – Part 3.

The consulting engineer shall complete Schedule C, Form F-13 and submit copies of all laboratory testing results to the City Engineer prior to connection of the new water system to the existing municipal water distribution system.



---

## **6.0 SANITARY SEWER SYSTEM**

### **A. DESIGN CRITERIA**

#### **6.1 General**

##### **6.1.1 Sanitary connection**

In any subdivision and/or development, a sanitary collection system to the dwelling must be provided.

##### **6.1.2 Municipal or Alternative Sanitary System**

Where connection to the City's sanitary distribution is required, connection shall be provided in accordance with Section 6.3 and the City's Sewer Connection Consolidation Bylaw No. 1410.

Where connection to the City's sanitary system is not required by this bylaw, all subdivision/developments shall have an on-site sanitary disposal/treatment system in accordance with Section 6.2.

#### **6.2 On-site Sanitary Systems**

Where a City sanitary distribution system is not available and extension of the system is not required, an on-site sanitary collection and treatment system shall be installed as per the requirements of the provincial Sewerage System Regulation (BC Reg 326/2004) as revised.

Right of ways may be required to be provided by the applicant to allow for the eventual installation of sanitary sewer. Such rights of ways shall be registered in favour of the City of Salmon Arm at the applicant's expense.

#### **6.3 Municipal Sanitary System**

No construction shall commence until engineering drawings and sanitary design sheets have been approved by the City Engineer.

##### **6.3.1 Engineering Drawings**

Engineering drawings shall show alignment, size, grade, class and depths of pipes, pipe bedding requirements, existing ground line and proposed final ground line over the pipe, location, elevation and detail of all manholes and appurtenances, location of all service connections, inspection chambers, location, access to, size and details of any lift stations, existing and proposed drainage boundaries and loading information, all easements and all such other details as may be required.

##### **6.3.2 Design Sheets**

Pipe Sizing calculations shall be submitted in the form of a design sheet. Refer to Specification Drawing SAN-9.

**6.4 Main Sizing**

The Sanitary system shall be designed with sufficient capacity to collect and convey anticipated flows from the total catchment area to be served when fully developed.

The owner/developer Consulting Engineer to review latest Sanitary Master Plan undertaken by the City to confirm sufficient downstream capacity for the proposed development and future development within each respective catchment boundary.

**6.4.1 Design Flow**

The design flow shall be the Peak Wet Weather Flow (PWWF)

$$PWWF = \text{Population (or equivalent)} \times \text{ADWF} \times \text{Peaking factor} + \text{Infiltration}$$

Where: ADWF is Average Dry Weather Flow

**6.4.2 Population**

Residential	People/Unit
Low Density (<= 16 Units/ha)	3.3
Medium Density (>= 17 and <= 45 Units/ha)	2.5
High Density (> 45 Units/ha)	1.8
Non-Residential	PE/ha
Commercial	90
Industrial	50
Institutional	90

**6.4.3 Average Dry Weather Flow**

Average Dry Weather Flow shall be 450 litres per capita per day for residential and 28,000 L/HA/Day for ICI (Industrial, Commercial, and Institutional) properties.

**6.4.4 Peak Flow Formula**

Peak flows shall be calculated using a peaking factor determined by the Harmon Formula:

$$\text{Peaking Factor} = \frac{18+p^{0.5}}{4+p^{0.5}}, \text{ where } P = \text{population in thousands}$$

**6.4.5 Infiltration**

Infiltration allowance of 0.1 litres/second/hectare (8,640 litres/ha/day).

**6.4.6 Pipe Flow Formula Gravity Main**

Gravity Sewers shall be designed, for ¾ depth, using Manning’s Formula

$$Q = \frac{AR^{0.667} S^{0.5}}{n}$$

- Where,
- Q = Design flow in m<sup>3</sup> per second
  - A = Cross sectional area in m<sup>2</sup>
  - R = Hydraulic radius in meters
  - S – Slope of hydraulic grade line in m/m
  - n – Roughness Coefficient

**6.4.7 Pipe Flow Formula Force Main**

Force Mains shall be designed using the Hazens-Williams Formula,

$$Q = \frac{CD^{2.63}S^{0.54}}{278 * 780}$$

- Where,
- Q = rate of flow in litres/second
  - D = internal pipe diameter in mm
  - S – Slope of hydraulic grade line in m/m
  - C = Roughness coefficient

**6.4.8 Minimum sanitary main diameter**

The minimum sanitary pipe diameter shall be 200mm.

**6.4.9 Velocities**

The minimum velocity for gravity sewer mains shall be 0.76 m/s, except as noted in Section 6.5.1.

There is no maximum velocity for gravity sewer mains, however, where the velocity exceeds 3.65 m/s consideration should be given to possible scour and shock hydraulic problems.

**6.5 Vertical Alignment**

**6.5.1 Pipe Grade**

The minimum pipe grades for pipes 375mm and smaller are:

Pipe Size (mm)	100	150	200	250	300	375
Grade (%)	2.00	1.00	0.45	0.33	0.25	0.20

There is no specified maximum pipe grade; however, gravity and Force Mains installed at grades in excess of 20% shall be reviewed for anchor block, trench dam and joint restraint requirements. See Specification Drawing No. UT-3 and UT-5.

Upstream sections of sewers require steeper grades to ensure self-cleansing velocity under partial flow conditions. The following design alternatives are acceptable:

- The terminal section servicing six (6) or less sanitary connections shall have a grade of 1% greater than the minimum grade specified above.
- A sewer line servicing the 7<sup>th</sup> to 12<sup>th</sup> sanitary connection shall have a grade of 0.5% greater than the minimum grade specified in above.

---

### 6.5.2 Hydraulic Losses Across Manholes

The minimum drop in invert level across manholes shall be:

---

Straight Run	Minimum grade
Deflections up to 45°	50mm drop
Deflections 45° to 90°	65mm drop

---

The crown of the incoming pipe must be at the same elevation as the crown of the outgoing pipe where a change in pipe diameter occurs through a manhole. (or the pipe diameter less the minimum drop where the drop exceeds the change in pipe diameter)

### 6.5.3 Drop Manholes

An outside drop manhole shall be installed where the elevation of the inlet invert is 900mm, or greater, above the invert elevation of the centre of the manhole channel.

Internal drop manholes are not permitted.

Drop manholes shall be designed in accordance with Specification Drawing No. SAN-3 and shall only be used when incoming sewers cannot be steepened or where site conditions do not permit otherwise.

### 6.5.4 Depth of Cover

The minimum depth of cover shall be 1.5 meters. City approval is required where sufficient cover is not feasible or available. Insulation may be required.

New sanitary sewers must be deep enough to provide gravity service to the furthest portion of a building envelope with normal basement elevations.

### 6.5.5 Vertical Curves

Vertical curves of segmented storm main are generally not permitted, however, where specific permission has been granted by the City Engineer, mains in vertical curves shall be uniform throughout the curve, the radius of curvature shall be not less than 50 meters, the pipe grade shall be not less than 1.0% and the design velocity must exceed 0.91 m/s. The deflection in all cases however must not exceed 50% of the manufacturer's recommendations.

### 6.5.6 Manhole Benching

Manhole benching to be 8:1 slope from crown of pipe.

## 6.6 Horizontal Alignment

### 6.6.1 Location in Roadway

Mains shall be aligned as indicated on the applicable road cross section Specification Drawings.

6.6.2 Horizontal Curves

Horizontal curves of segmented sanitary main are generally not permitted, however, where specific permission has been granted by the City Engineer, mains in horizontal curves shall be uniform throughout the curve. The radius of curvature shall be not less than 60 meters, the pipe grade shall be not less than 1.0% and the design velocity must exceed 0.9 m/s. The deflection of pipes in all cases must not exceed 50% of the manufacturer’s recommendations for maximum deflection. Tracer wire shall be installed along the curved portion of the sewer.

6.6.3 Sanitary Manholes

Manholes are required at all changes in grade, alignment, size and dead-end mains and not further apart than:

Pipe Size (mm)	375 and smaller	450 to 900	1050 and larger
Maximum Spacing (m)	125	155	185

Manhole lids shall not conflict with curbs, gutters or sidewalks, and where possible shall be located outside of the wheel path of normal traffic flow.

Manhole liners may be required at the City Engineer’s request.

6.6.4 Clean-outs

Clean-outs are not permitted in place of manholes except where the sanitary sewer main will be extended for future subdivision/development.

**6.7 Service Connections**

All connections/disconnections to the City sanitary sewer infrastructure shall be in accordance with the Sewer Connections Consolidation Bylaw #1410

6.7.1 Number of Services

A single service shall be provided to each legal lot. Strata developments and other major developments will be permitted only one connection unless otherwise approved by the City Engineer where site conditions warrant additional connections or where a single service connection is not practical.

6.7.2 Diameter

Sanitary sewer services shall be a minimum of 100mm diameter. Each service shall be installed with an inspection chamber at a minimum grade of 2.0%. Service connections shall be installed and located in accordance with Specification Drawings No. SER-1, SAN-4 and SAN-6.

Sanitary sewer services to multi-family sites, mobile home parks, institutional, commercial and industrial sites shall be sized (minimum 100mm diameter) as required by the current

---

edition of the British Columbia Plumbing Code. Each service shall be installed with an inspection chamber and for sizes up to 150mm and with a manhole at sewer main for sizes greater than 150mm. Refer to Specification Drawings No. SAN-4 and SAN-6.

#### 6.7.3 Depth and Grade

Sanitary sewer services shall be designed to permit normal basement service to all proposed lots. In all cases, the minimum service grade is 2.0%. Pumping may be allowed with City Engineer approval; however, the service from the main to property line shall be a gravity line at 2.0% min.

#### 6.7.4 Connection into Manhole

A service connection entering a manhole shall have its invert elevation at the crown of the highest main entering the manhole. The service connection shall discharge in the same direction as the benched flow in the sewer main.

#### 6.7.5 Inspection Chambers

The inspection chamber at the end of each service pipe must be located 300mm from the property line, on the road right of way and offset 4.0m from the centre of each lot. Where such locations will conflict with other services, the location may be revised with the approval of the City Engineer. Where inspection chambers are located within driveways, they shall be protected using a Brooks Box or approved equivalent. Refer to Specification Drawings SER-1 and SAN-6.

### **6.8 Force Mains**

#### 6.8.1 Diameter

The minimum force main diameter shall be 100mm.

#### 6.8.2 Velocity

The maximum force main velocity shall be 3.65 m/s and the minimum cleaning velocity shall be 0.9 m/s.

#### 6.8.3 High Points

Air release and vacuum valves, suitable for sewage flow, shall be installed at the high points in all force main installations. Refer to Specification Drawing No. SAN-7.

#### 6.8.4 Tracer Wire

Force main pipes shall be installed with a locating tracer wire.

#### 6.8.5 Connection to Manhole

Force mains shall enter receiving manholes at crown to crown elevation and direct the flow into the receiving channel without excessive spray and in the direction of the receiving sewer flow.

## **6.9 Pump Stations**

The City will directly retain consultants for the design and construction supervision of new or modifications to existing pump stations and electrical and SCADA controls for the City's sewer utilities.

### **B. MATERIALS**

Sanitary sewer materials shall be supplied in accordance with Schedule D – Approved Materials List.

### **C. INSTALLATION**

Sanitary sewer installation shall be in accordance with Master Municipal Construction Documents (MMCD) Platinum Edition Volume 2 (The MMCD Association, 2009) as amended and Schedule B – Part 3.

### **D. CLEANING, FLUSHING AND TESTING**

Sanitary sewer cleaning, flushing and testing shall be in accordance with Master Municipal Construction Documents (MMCD) Platinum Edition Volume 2 (The MMCD Association, 2009) as amended and Schedule B – Part 3.

---

## **7.0 STORM WATER MANAGEMENT**

### **A. DESIGN CRITERIA**

#### **7.1 General**

All Subdivision and Development within the City of Salmon Arm shall be designed to minimize the effect on the natural hydrological and hydro geological regimes, while not compromising the safety of persons or property.

Reference may be made to ‘Stormwater Planning: A Guidebook for British Columbia’ (Ministry of Water, Land and Air Protection, May 2002) for example of low impact development and best management practices.

[http://www2.gov.bc.ca/assets/gov/topic/7BE6D1629C96685698920E29284EBCF4/stormwater\\_planning\\_guidebook\\_for\\_bc.pdf](http://www2.gov.bc.ca/assets/gov/topic/7BE6D1629C96685698920E29284EBCF4/stormwater_planning_guidebook_for_bc.pdf)

The stormwater design shall conform to the storm water management plan for each drainage basin as detailed in the current edition of the City of Salmon Arm ‘Comprehensive Drainage Planning’ report. The owner/developers consulting engineer to review the drainage master plans prepared by the City and confirm sufficient downstream capacity.

##### **7.1.1 Integrated Stormwater Management Plan**

An integrated stormwater management plan (report, drawings, design sheets, etc.) prepared by a Professional Engineer or Geoscientist with related experience is required for all subdivision and development where there is or will be an increase in the impermeable area on the site. The complexity of the plan should reflect the complexity of the development.

An integrated stormwater management plan shall use best management practices to minimize the effect to the natural hydrological and hydro geological regimes, while not compromising the safety of persons or property.

Design professionals must consider impacts of climate change, using best practices, in their integrated stormwater management solution.

A stormwater management plan shall attempt to achieve the following parameters where appropriate. Note: Mean Annual Rainfall (MAR) shall be calculated according to the method outlined in Stormwater Planning, A Guidebook for British Columbia (Ministry of Water, Land and Air Protection, 2002).

- Eliminate discharge (infiltrate or reuse) from impervious surface areas for storm events with rainfall depths up to one half of the 24-hour MAR, approximately 10mm.
- Capture of runoff exceeding one half of the 24-hour MAR (approximately 10mm) up to the 24-hour MAR (approximately 20mm) and release at the pre-development interflow rate to storm sewer or natural drainage course.



- 
- For storm events that exceed the 24-hour MAR, safe conveyance of runoff shall be provided. Where storm sewer is available/required, flows up to and including the 25-year storm shall be conveyed in the sewer. Consideration for safe overland flow routes shall be at minimum to the 100-year storm.

### 7.1.2 Municipal or Alternative Storm System

Where connection to the City's stormwater collection system is required, connection shall be provided in accordance with Section 7.3 and the City's Sewer Connection Consolidation Bylaw No. 1410.

Where connection to the City's stormwater collection system is not required by this bylaw, all subdivision/developments shall have an alternative stormwater system in accordance with Section 7.2.

## 7.2 **Alternative Stormwater Systems**

Where connection to the City's stormwater collection system is not required an alternative stormwater management system is required to address additional runoff created by subdivision or development. All stormwater management systems shall use best management practices to minimize the effect to the natural hydrological and hydro geological regimes, while not compromising the safety of persons or property. When necessary, changes to the natural drainage patterns shall not adversely affect upstream or downstream properties.

### 7.2.1 Sheet Drainage

Sheet drainage over natural or landscaped areas is an acceptable means of dispersing stormwater from new development on lots where:

- impervious area is less than 10% of the total lot area or the proposed development footprint is less than 30m<sup>2</sup>;
- all setbacks have been adhered to as specified in the Zoning Bylaw, and;
- Topography is such that there is minimal chance of adverse impacts on adjacent lots.

A covenant is not required where this option is permitted.

### 7.2.2 Infiltration Systems

Infiltration systems shall be designed to infiltrate the 24-hour Mean Annual Rainfall (MAR) into the native soils within 48 hours. They shall be designed as per the 'Underground Stormwater Infiltration – Best Practices for Protection of Groundwater Resources in British Columbia' (BC MOE, 2014).

MAR to be calculated according to the method outline in 'Stormwater Planning: A Guidebook for British Columbia (Ministry of Water, Land and Air Protection, 2002'.

All infiltration systems shall have pre-treatment which at minimum shall be a sump with an accessible cleanout.

---

A safe overflow route shall be provided for storms in excess of the capacity of the infiltration system.

A geotechnical report certifying that the operation of the system will not create or exacerbate geotechnical hazards shall be provided.

Depending on size of infiltration system, complexity, proximity to steep slopes or proximity to known stormwater related concerns, a full hydro geological investigation may be required to support the proposed infiltration system.

A covenant is required where this option is permitted. Refer to Section 7.2.4.

Infiltration systems should NOT be considered where there is a potential for slope instability or contamination of aquifers.

### 7.2.3 Low Impact Development Infrastructure

Low Impact Development (LIDs) infrastructure such as absorbent landscaping materials, vegetated swales, permeable pavement, infiltration aids, etc. shall be reviewed on a case-by-case basis for conformity with the intent of the Section 7.0 of the City's Subdivision and Development Bylaw.

All LIDs shall be designed by a Professional Engineer with related experience and shall be certified upon installation.

Any LIDs that have an installation footprint and/or maintenance requirements shall be clearly identified on an individual lot plan along with an Operation and Maintenance report. A covenant shall be placed on title in accordance with Section 7.2.4.

### 7.2.4 Covenant

Where a covenant is required for approvals, the owner/developer must register on title of each lot serviced by an on-site stormwater system, a covenant in favour of the City of Salmon Arm with reference to any geotechnical or Operation and Maintenance requirements. The form of the covenant shall be approved by the Approving Officer and City Engineer.

### 7.2.5 Statutory Right of Way

Where a storm system is not yet available, right of ways may be required to be provided by the applicant to allow for the eventual installation of this facility. Such right of ways shall be registered in favour of the City of Salmon Arm at the applicant's expense.

## 7.3 **Municipal Stormwater Collection System**

No construction shall commence until engineering drawings, sewer design sheets and stormwater report have been approved by the City Engineer.

The storm drainage system shall include the entire area tributary to the storm drain and shall be designed with sufficient capacity to collect and convey anticipated storm runoff from the total catchment area to be served when fully developed.

---

### 7.3.1 Engineering Drawings

Engineering drawings shall show alignment, size, grade, class and depth of pipes, pipe bedding requirements, existing ground line and proposed final ground line over the pipe, location, elevation and detail of all manholes, catch basins and other stormwater related appurtenances, location of all service connections, inspection chambers, location, access to, size and details of retention or infiltration systems, existing and proposed drainage boundaries and loading information, major and minor flow routes, all easements and all such other details as may be required.

### 7.3.2 Stormwater Report

The Stormwater Report shall give an overview of the integrated stormwater plan and outline how the proposed stormwater system achieves the stormwater objectives outlined in Section 7.1.1 to the greatest extent possible. All calculations, design parameters, assumptions, etc. shall be outlined in the report.

### 7.3.3 Design Sheets

Rational Method design calculations are to be tabulated and submitted to the City as part of the Stormwater Report, refer to Specification Drawing ST-15.

## 7.4 Design Flows

### 7.4.1 Major and Minor Flow Calculations

For drainage basins greater than 10 hectares in size, design flows shall be based on computer storm modeling, or other methods acceptable to the City.

For drainage basins less than 10 hectare in size, the design flows shall be based on the rational method,

$$Q = RAIN$$

Where,    Q = Peak Rate of Run-off in m<sup>3</sup>/sec  
          R = Run-off coefficient  
          A = Area of watershed in Hectares  
          I – Average Rainfall Intensity in mm/hr  
          N = 1/360

### 7.4.2 Peak Rate Run-off (Design Storms)

Minor Flow shall be the 1 in 25 year 24-hour Chicago Rainfall event peak rate of runoff.

Major Flow shall be the 1 in 100 year 24-hour Chicago Rainfall event peak rate of runoff less any piped minor flow.

Post-development design flows and capacity calculations shall include an additional ten percent (10%) upward adjustment applied to the rainfall intensity calculations and be consistent with recommendations in Legislated Flood Assessments in a Changing Climate in BC (EGBC, 2018).

**7.4.3 Pre-development Flow**

Pre-development flows have been modelled through the City’s Stormwater Master Plan (ISL, 2020). The watershed pre-development run-off rate Mean Annual Flood (MAF) is 1.3 L/s/ha and shall be used where development ultimately discharges into a water course or natural waterbody other than Shuswap Lake.

Where development runoff is conveyed through urban development (pipes/roads) to Shuswap Lake, the pre-development run-off rate shall be calculated using best practices assuming a true ‘pre-development’ forested/vegetated state of the development property.

**7.4.4 Run-off Coefficient**

Run-off Coefficients, for slopes of 5% and flatter, shall be as follows:

Description of Area	Gravel-Loam	Loamy Sand	Clay
Forest/Woodlands	0.05	0.10	0.15
Public, Recreation, Open Space, Grassland (ALR)	0.10	0.20	0.35
Residential (Suburban, Lots > 0.4ha)	0.25	0.35	0.45
Residential (Low Density)	0.40	0.50	0.60
Residential (Medium Density)	0.50	0.60	0.70
Residential (High Density)	0.65	0.75	0.85
Neighborhood Commercial	0.50	0.60	0.70
Heavy Commercial	0.70	0.85	0.95
Industrial	0.55	0.70	0.80
Pavement or other impermeable surface	0.90	0.90	0.95

Where slopes exceed 5% the above run-off coefficients shall be increased by 10%, compound, for each 5% increment in slope.

**7.4.5 Rainfall Intensity**

The rainfall intensity for the rational method can be extrapolated from the City rainfall Intensity/Duration/Frequency Curves (refer to Specification Drawing No. ST-7) or calculated by:

$$I = A \times T^B$$

Where, I = rainfall intensity in mm/hr  
 T = Storm duration in hours  
 A,B = constants

Parameter	Return Frequency					
	2 Year	5 Year	10 Year	25 Year	50 Year	100 Year
a	10	16.4	20.9	26.7	31.1	35.6
b	0.706	0.786	0.821	0.854	0.873	0.888
c	0.02	0.08	0.111	0.142	0.16	0.176

**7.4.6 Design Time of Concentration**

The time of concentration is the time required for run-off to flow from the most remote part of the catchment area under consideration to the design node. The time of concentration can be calculated using the following formulas:

$$T_c = T_i + T_t$$

Where,  $T_c$  = time of concentration (minutes)

$T_i$  = inlet or overland flow time (minutes)

$T_t$  = travel time in sewers, ditches, channels or water courses (minutes)

Inlet Times ( $T_i$ ) - Minimum inlet times are 15 minutes for residential areas, and 10 minutes for industrial and commercial areas. Inlet times for larger areas can be calculated using the “Airport Method” or equivalent.

Travel Time ( $T_t$ ) – Travel time in sewers, ditches, channels or watercourses can be estimated using the modified Manning formula.

Additional information concerning drainage contributing areas and time of concentration is available in the current edition of the City’s current Stormwater Master Plan.

**7.4.7 Snow Melt**

In all cases the Design Engineer (in determining the critical design conditions) is to consider the impact of snowmelt on the drainage system.

**7.5 Minor System Design**

**7.5.1 Design Storm**

Storm sewers shall be designed for the 25 year peak storm return frequency.

**7.5.2 Pipe Flow Formula**

Gravity storm sewer systems shall be designed for full flow, using Manning’s Formula as noted below:

$$Q = \frac{AR^{0.667}S^{0.5}}{n}$$

Where,  $Q$  = Design flow in m<sup>3</sup>/sec  
 $A$  = Cross sectional area in m<sup>2</sup>  
 $R$  = Hydraulic radius in meters  
 $S$  = Slope of hydraulic grade line in m/m  
 $n$  = Roughness Coefficient

The value of ‘n’ using Manning’s Formula shall be:

PVC, HDPE	0.011
Concrete	0.013
Corrugated Steel Pipe (CSP)	0.024

**7.5.3 Minimum Storm Main Diameter**

The minimum pipe diameter shall be 250 mm for mains and 200 mm for catch basins.

**7.5.4 Velocities**

The minimum velocity shall be 0.75 m/s for gravity storm mains

There is no maximum velocity, however, where the velocity exceeds 3.65 m/s consideration shall be given to possible scour and shock hydraulic problems.

**7.5.5 Design Flow Adjustment for LIDs**

Where low impact development (LID) best management practices are used, mains may be sized according to the required capacity taking 50% of the groundwater recharge capability into consideration. The groundwater recharge component must be calculated and justified by a qualified hydrologist/engineer with experience in this field. Minimum sizes of mains must still be observed.

**7.6 Vertical Alignment**

**7.6.1 Pipe Grade**

The minimum slope for the first reach of permanent dead end sewer shall be 1%, where feasible. For sewers other than the first permanent dead end reach, the minimum pipe grades are:

Size (mm)	200*	250	300	375	450	525	600	675	750	825	900
Grade (%)	2.00	0.40	0.32	0.23	0.20	0.18	0.15	0.12	0.10	0.09	0.07

\*Catchbasin leads only

There is no specified maximum pipe grade; however, mains installed at grades in excess of 20% shall be reviewed for anchor block, trench dam and joint restraint requirements. See Specification Drawing No. UT-3 and UT-5

**7.6.2 Hydraulic Losses Across Manholes**

The minimum drop in invert levels across manholes are:

Straight Run	Minimum grade
Deflections up to 45°	50mm drop
Deflections 45° to 90°	65mm drop

Horizontal changes of direction greater than 90 degrees are not permitted.

Where a change in diameter occurs across a manhole, the drop shall be a minimum of the difference in the diameters of the pipe or the drop specified above, whichever is greater.

---

### 7.6.3 Drop Manholes

An outside drop manhole shall be installed where the elevation of the inlet invert is 900mm, or greater, above the invert elevation of the centre of the manhole channel.

Internal drop manholes are not permitted.

Drop manholes shall be designed in accordance with Specification Drawing No. ST-16 and shall only be used when incoming sewers cannot be steepened or where site conditions do not permit otherwise.

### 7.6.4 Depth of Cover

The minimum depth of cover shall be 1.5 meters. City approval is required where sufficient cover is not feasible or available. Insulation may be required.

New storm sewers shall have sufficient depth to allow gravity connections from 0.3 meters below the existing or proposed basement floor elevation (at the furthest building envelope point).

### 7.6.5 Vertical Curves

Vertical curves of segmented storm main are generally not permitted, however, where specific permission has been granted by the City Engineer, mains in vertical curves shall be uniform throughout the curve, the radius of curvature shall be not less than 50 meters, the pipe grade shall be not less than 1.0% and the design velocity must exceed 0.91 m/s. The deflection in all cases however must not exceed 50% of the manufacturer's recommendations.

### 7.6.6 Manhole Benching

Manhole benching to be 8:1 slope from crown of pipe.

## 7.7 **Horizontal Alignment**

### 7.7.1 Location in Roadway

Mains shall be aligned as indicated on the applicable Road Cross-Section.

### 7.7.2 Horizontal Curves

Horizontal curves of segmented storm main are generally not permitted, however, where specific permission has been granted by the City Engineer, mains in horizontal curves shall be uniform throughout the curve, the radius of curvature shall be not less than 50 meters, the pipe grade shall be not less than 1.0% and the design velocity must exceed 0.91 m/s. The deflection in all cases however must not exceed 50% of the manufacturer's recommendations.

### 7.7.3 Storm Manholes

Storm Manholes shall conform to Specification Drawing No. ST-2.

Manholes are required at all changes in grade, alignment, size, dead end mains and at existing and planned intersecting storm sewers.

The maximum spacing between manholes shall be as follows:

Pipe Grade (%)	Less than 5%	5%-10%	Greater than 10%
Maximum Spacing (m)	150m	120m	60m*

\*or as directed by City Engineer

Combination catch basin-manholes are generally not permitted.

Manhole lids shall not conflict with curbs, gutters or sidewalks, and where possible shall be located outside of the wheel path of normal traffic flow.

**7.7.4 Clean-outs**

Clean-outs/Inspection chambers are not permitted in place of manholes except where the storm sewer main will be extended for future subdivision/development.

Location shall not conflict with curbs, gutters or sidewalks, and where possible shall be located outside of the wheel path of normal traffic flow.

**7.8 Service Connections**

All connections/disconnections to the City Storm sewer infrastructure shall be in accordance with the Storm Connection Bylaw #1410.

**7.8.1 Number of Services**

A single service shall be provided to each legal lot. Strata developments and other major developments will be permitted only one connection unless otherwise approved by the City Engineer where site conditions warrant additional connections or where a single service connection is not practical.

**7.8.2 Diameter**

Storm sewer services to single family dwellings and duplexes shall be a minimum of 150mm diameter. Each service shall be installed with an inspection chamber at a minimum of 2.0%. Service connections shall be installed and located in accordance with Specification Drawings SER-1, ST-4 and ST-6.

All multi-family sites, mobile home parks, institutional, commercial and industrial sites shall have a storm sewer system designed adequately to service the parcel. In no case will the service be less than 150mm diameter.

**7.8.3 Depth and Grade**

Storm sewer services shall be designed to permit normal basement service, as required by the Building Code, to all proposed lots. In all cases, the minimum service grade is 2.0%.

**7.8.4 Connection into Manhole**

A service connection entering a manhole shall have its crown at the crown of the highest main entering the manhole. The connection shall discharge in the same direction as the flow in the sewer main.



---

### 7.8.5 Inspection Chambers

The inspection chamber at the end of each service pipe must be located 300mm from the property line, on the road right of way and offset 3.0m from the centre of each lot. Where such locations will conflict with other services, the location may be revised with the approval of the City Engineer. Where inspection chambers are located within driveways, they shall be protected using a Brooks Box or approved equivalent. Refer to Specification Drawings SER-1 and ST-6.

Manholes will be required in place of inspection chambers for storm sewer connections as specified on Specification Drawing ST-5.

## 7.9 Foundation Perimeter Drains and Roof Leaders

Foundation perimeter drains shall be connected to a gravity storm system where possible, or otherwise outlet to an infiltration system (refer to Section 7.2.2). Where grade differences permit, foundation drains may be outlet within the property boundaries where doing so will not cause adverse impact to adjacent properties.

Connection of roof leaders shall be addressed as part of the overall integrated stormwater management plan. Roof drainage leaders are to be connected to the storm service only where geotechnical requirements dictate the need. Where direct connection is necessary, all efforts shall be made to slow runoff using LID techniques. Roof leaders shall not be directed onto impervious services which drain directly onto City right-of-way or adjacent properties.

## 7.10 Catch basins

### 7.10.1 Spacing

Catch basins shall be installed at regular intervals along roadways, at intersections, and at low points. Refer to Specification Drawing No. ST-1 and ST-14.

Catch basins shall be spaced to drain a maximum area of 500m<sup>2</sup> on road grades up to 5% and 400m<sup>2</sup> on steeper grades.

In any event, catch basin spacing shall not exceed 75 meters.

### 7.10.2 Double Catch Basins

Double catch basins are required at all low points when water is collected from two directions. A single catchbasin may be considered if the total catchment area is less than the allowable area noted above.

### 7.10.3 Side Inlets

Side inlet catch basins are required where road grades exceed 5%.

### 7.10.4 Catchbasin Leads

The minimum lead size diameter shall be 200mm for a single catch basin lead and 250mm for a double catch basin lead. The maximum length of a catch basin lead shall be 25 meters.

---

### 7.10.5 Location

Wherever possible, catch basins are to be installed at the EC or BC for all curb returns. In no cases shall a catch basin be located in a wheelchair sidewalk ramp or driveways access.

### 7.10.6 Rear Yard Catchbasin

Rear yard catch basins require a sump manhole at the connection to the mainline regardless of lead size. All infrastructure shall be protected by a Right-of-way in favour of the City.

## 7.11 **Major Flow Routing**

### 7.11.1 General

The major system includes all drainage pathways that convey, detain, divert and intercept the major design storm runoff. The combined capacity of the major (overland) and minor (piped) systems must be able to safely contain storm flows resulting from the 1:100 year design storm.

Major flow routing over 0.05 m<sup>3</sup>/s shall be shown and sufficient design shall be carried out to provide assurance to the City Engineer that no serious property damage or endangering of public safety will occur under major flow conditions. The discharge point from the development for the major flow route shall be coordinated with the downstream routing to outfalls as determined by the City of Salmon Arm.

### 7.11.2 Design Storm

Culverts shall be designed for the 100 year peak storm return frequency, unless otherwise specified by the City Engineer.

Culverts under Arterial roadways shall be designed for the 100 year peak storm return frequency with 50% blockage.

Ditches and overland flow routes shall be designed to accommodate 100 year peak storm return frequency (referred to as Major Storm) for the appropriate time of concentration, less any minor flows directed to the storm sewers.

Emergency flow routes shall be designed to accommodate the 100 year peak storm return frequency for the appropriate time of concentration.

All Storm flow calculations shall take into account Climate Change predictions per EGBC Best Practices.

---

### 7.11.3 Major Route Flow Sizing

Overland flow channel capacities shall be calculated using the Manning Formula at critical design sections. All habitable areas of buildings shall be above the major flow hydraulic grade line, except where specified flood prevention measures have been taken. Typical Manning Roughness Coefficient 'n' are:

- 0.018 for paved roadway
- 0.03 for grassed boulevards and swales
- 0.04 to 0.10 for irregular or treed channels

### 7.11.4 Location

Major flows shall be contained within public road allowances and right of ways, and shall discharge off-site to public road allowances and right of ways capable of accepting the design flows.

### 7.11.5 Major Flow on Roadways

Where the road is used to accommodate major flow, it shall be formed, graded and sufficiently depressed below the surrounding properties to provide adequate hydraulic capacity. On arterial roads, a minimum of 6.0m width (two (2) lanes) shall be free of ponding. On Collector and local roads, the entire roadway may be used as a major flood path with the maximum flow depth not to exceed 200mm.

Where roadways, used for major flows, intersect, care shall be taken to lower the intersection to allow flows to pass over the cross street. Where major flow routes turn at intersections similar care in the road grading design is required. Detailed grading of such areas shall be shown on drawings.

### 7.11.6 Erosion Protection

Major flow channels shall be designed to resist erosion or other detrimental effects at design flow.

Where major flow outfalls to a receiving water course, the velocity shall not exceed 1.5 m/s. An energy dissipater shall be provided to minimize erosion.

### 7.11.7 Storm Sewer

In areas where surface major flow routes cannot be provided, or where desired to enable lower building elevations, the pipes and culverts, which form a part of the minor system, may be enlarged or supplemented to accommodate the major flow.

## 7.12 **Hydraulic Grade Line**

### 7.12.1 General

All storm sewer designs must indicate the 100 year HGL. Where necessary, minimum basement elevations should be specified on the grading drawing to ensure a minimum of 0.3 meters of clearance from underside of slab to the 100 year HGL.

---

### 7.12.2 Hydraulic Grade Line Formula

Hydraulic Grade Line (HGL) shall be calculated using the Darcy – Weisbach equation as noted below and specified on profile drawings:

$$h_f = \frac{f \times L}{D} \times \frac{V^2}{2g}$$

Where,  $h_f$  = head loss due to friction in meters  
L = length of the pipe in meters  
D = hydraulic diameter of the pipe in meters  
V = average velocity of the fluid flow, equal to the volumetric flow rate per unit cross-sectional wetted areas (m/s)  
g = local acceleration due to gravity (m/s<sup>2</sup>)  
f = dimensionless coefficient called the Darcy Friction Factor

The starting HGL shall be the greater of the downstream pipe invert or the 100 year flood elevation of the water course/body

### 7.12.3 Inlet Control Devices

Inlet control devices (ICDs) may be installed in catch basin where need necessary to lower the HGL. Backflow preventers on storm drains, ICDs or Minimum Basement Elevations (MBEs) may be utilized at the discretion of the City Engineer. Backflow preventers on private services shall be located on private property.

### 7.13 **Drainage Ditches/Culverts**

Drainage ditches and culverts shall be sized based on the design storms referenced in Section 7.11.2.

In no cases, shall a culvert be less than 400mm in diameter.

Erosion control and/or additional velocity restricting designs may be required as determined by the City Engineer.

Inlet/outlet structures shall be installed on all culverts at roadway crossings as per Section 7.14.

Where fronting residential properties, due consideration shall be given to ease of maintenance.

### 7.14 **Inlet and Outlet Structures**

#### 7.14.1 General

Inlet and Outlet Structures shall be designed, and submitted for approval, for each particular application. Precast Inlet and Outlet structures are preferred. Refer to Specification Drawing No. ST-8, ST-9 and ST-10.

Trash racks, energy dissipation, railings, monitoring devices, oil separators, inlet sumps, safety grates and rip-rap shall be provided as required.

---

7.14.2 Safety Grates and Hand Rails

Lockable, hinged, manufactured safety grates are required on open inlets and outlets 300mm and larger. Refer to Specification Drawing No. ST-11

A handrail shall be installed around inlet/outlet structures 1.2 meters or larger in height.

7.14.3 Erosion Control

Erosion control and/or additional velocity restricting designs may be required as determined by the City Engineer.

**7.15 Quality Control**

7.15.1 General

Quality control shall be provided for flows up to 50% of the 2 year post development peak flow ('first flush' storm) or the 5 year pre-development peak flow, whichever is greater. Quality treatment facilities include, but are not limited to, oil/grit separators, trapping hoods, sumps, silt traps, detention storage facilities, grassed swales and constructed wetlands.

Treatment facilities should include provisions for maintenance equipment access.

7.15.2 Oil/Water Separators (OWS)

Oil/water separators including coalescing plate separators shall be provided on the storm service, on private property, for all gas stations, vehicle service areas and storage areas for vehicles and construction equipment. A covenant must be placed on title alerting the property owner to the maintenance requirements, etc.

7.15.3 Oil/grit Separators (OGS)

OGS shall be provided on the storm services, on private property, for sites with parking for 50 or more vehicles. OGS shall be a swirl concentrator or equivalent. Design details to be provided by supplier of proprietary system or by designer of equivalent.

OGS will be designed to treat a minimum of 90% of the annual runoff volume of the catchment area.

An internal high flow bypass shall be provided that conveys high flows directly to the outlet such that scour and re-suspension of material previously collected does not occur.

OGS shall be capable of removing 80% of the total suspended sediment load (TSS including fine and clay particles) and 95% of the floatable free oil.

Maintenance access shall be provided to and into the structure for removal of accumulated sediments and oils with a vacuum truck.

OGS shall be installed in a water tight concrete manhole or vault structure.

Where an OGS and detention storage are required, the OGS shall be installed immediately upstream of any required detention storage facility.

---

#### 7.15.4 Detention Storage Facilities

Underground detention facilities shall be complete with a sump upstream of the control orifice with an accessible clean-out, with exception to storage immediately downstream of an OGS unit (refer to Section 7.15.3).

Above ground detention facilities shall be complete with a sediment forebay with an access road for clean-out equipment. Design parameters may be made available upon request.

### 7.16 **Quantity Control**

#### 7.16.1 General

Quantity control is required on all development properties to minimize the effect to the natural hydrological and hydro geological regimes, while not compromising the safety of persons or property. Best efforts shall be made to provide quantity control to meet the criteria outlined in Section 7.1.1.

#### 7.16.2 Detention Facilities

The design of stormwater detention facilities shall be completed by a Professional Engineer qualified in hydrological design.

In general the City encourages detention facilities to be:

- Multi-use facilities that include recreational, environmental and aesthetic aspects as well as flow control and water quality control
- Accessible, including all inlet/outlet structures
- Above ground where possible. In pipe storage within City right of way is discouraged.

##### 7.16.2.1 Above Ground Detention

Detention basins shall be sized to match post-development to pre-development flows up to and including the 25 year storm with safe overland provisions for up to the 100 year storm. Detention basins shall have emergency overflow weirs and a sediment forebay with access road for operations and maintenance.

##### 7.16.2.2 Underground Detention

Where use of underground detention facilities is approved by the City, the facility shall be designed with sumps and access for operations and maintenance to the satisfaction of the City Engineer.

##### 7.16.2.3 Private Detention Facilities

Stormwater retention for commercial, industrial, institutional and multi-family residential may be at surface and/or underground. Rooftop and parking lot storage may be considered where appropriate. B.C. Building Code and City bylaw restrictions shall be met when designing rooftop storage.

---

7.16.3 Orifice

Orifice size shall be greater than 90mm unless otherwise approved by the City Engineer. Where smaller orifices are required, due consideration shall be given to minimize potential plugging of the orifice and to ensure appropriate emergency overflows and maintenance access is provided.

7.16.4 Infiltration Systems

Refer to Section 7.2.2.

7.16.5 Low Impact Development Infrastructure

Refer to Section 7.2.3.

7.16.6 Natural Drainage Courses

A natural drainage course may remain within private property, with provision for right of way unless under special circumstances such as where the City retains or acquires ownership for park or buffer use.

A natural drainage course shall not be altered or diverted, including altering the contributing drainage area, unless such alteration or diversion has been approved by the City Engineer and all other governing authorities.

Developments that outlet to a natural drainage course shall take all reasonable measures to mimic the naturally occurring hydrology of the basin using best management practices to slow the runoff to pre-development levels. In all cases, outlet to a natural drainage course shall not exceed 1.3 L/s/ha unless otherwise approved by the City Engineer.

Developments that outlet to natural drainage courses shall have suitable quality control, refer to Section 7.15

**B. MATERIALS**

Storm sewer materials shall be supplied in accordance with Schedule D – Approved Materials List.

**C. INSTALLATION**

Storm sewer installation shall be in accordance with Master Municipal Construction Documents (MMCD) Platinum Edition Volume 2 (The MMCD Association, 2009) as amended and Schedule B – Part 3.

**D. CLEANING, FLUSHING, TESTING**

Storm sewer cleaning shall be in accordance with Master Municipal Construction Documents (MMCD) Platinum Edition Volume 2 (The MMCD Association, 2009) as amended and Schedule B – Part 3.

---

## **8.0 STREET LIGHTING**

### **A. DESIGN CRITERIA**

#### **8.1 British Columbia Electrical Code**

The Street Lighting Design shall satisfy the BC Safety Authority Electrical Safety Regulation, Canadian Electrical Code including BC amendments.

#### **8.2 Materials**

Electrical materials used in the street lighting system shall be new, labelled and approved by the Canadian Standards Association or equivalent.

Conduit shall be Rigid PVC (RPVC) unless otherwise approved by the City Engineer.

Street Lights shall be Light Emitting Diode (LED) with 7 pin receptacle on all lights with dimmable driver and control (photo cell, shorting cap or controller).

#### **8.3 Levels of Illumination**

The average levels of illumination shall be in accordance with the Illuminating Engineering Society of North America (IESNA) RP-8-14.

Where a local road intersects with a Collector or Arterial (Major) roadways, the lighting levels shall meet or exceed the values recommended in IESNA RP-8-14, Table 8.

#### **8.4 Pole Type**

Davit poles and fixtures shall be located on all Collector and Arterial (Major) roads. Davit fixtures may be required at intersections other than Collector and Arterial, at the discretion of the City Engineer. Davit fixtures shall be located in industrial areas. Davit luminaires shall be in accordance with Specification Drawing No. SL-1 and SL-2, and in accordance with current Schedule “D” approved materials list.

Decorative top poles and fixtures shall be located within the Town Centre Development Area. Decorative top street lights shall be in accordance with Specification Drawing No. SL-3, SL-4, SL-5, SL-3-I and SL-4-I, and in accordance with current Schedule “D” approved materials list.

Residential type poles and fixtures shall be located on all local class classified roads and all areas not specified above. Residential type street lights shall be in accordance with Specification Drawing No. SL-3, SL-4, SL-5, SL-3-I and SL-4-I and in accordance with current Schedule “D” approved materials list.

Handhole shall be tamperproof.



---

### **8.5 Location**

Street light Poles shall be off-set as indicated on the applicable road cross-section.

Pole locations, in general shall be aligned with property lines and shall not conflict with driveways, fire hydrants, parking stalls or underground services. Poles shall be located as not to inhibit the movement of snow clearing equipment.

### **8.6 Electrical Service Connections**

Hydro service connections for street lights shall be made to a buried Hydro service box.

Electrical service connections shall be made to a junction box, power pole or lamp standard power base. All electrical designs must incorporate a power base.

### **8.7 Electrical Permit**

Safety Authority Electrical Permit must be submitted to the City within three (3) months of the application date.

## **B. MATERIALS**

Street Lighting materials shall be supplied in accordance with Schedule D – Approved Materials List.

## **C. INSTALLATION**

Street Lighting installation shall be in accordance with Master Municipal Construction Documents (MMCD) Platinum Edition Volume 2 (The MMCD Association, 2009) as amended and Schedule B – Part 3. The locations of all Street Light conduits shall be recorded and included on the Record drawings, together with all street lights, identifying lights that have the power base.

## **D. TESTING**

Street Lighting installation shall be in accordance with Master Municipal Construction Documents (MMCD) Platinum Edition Volume 2 (The MMCD Association, 2009) as amended and Schedule B – Part 3.

---

## **9.0 HYDRO, TELECOMMUNICATIONS, GAS**

### **A. DESIGN CRITERIA**

#### **9.1 General**

Where civil works to support hydro, telecommunications and/or gas infrastructure are required by Bylaw No. 4293, the applicant shall construct the works consistent with the regulations, standards and specifications set out in this schedule.

The location of the utility within the road right-of-way shall be as per the applicable road cross-section. See Specification Drawings RD-1 through RD-16.

#### **9.2 B.C. Hydro**

B.C. Hydro servicing shall be designed to B.C Hydro Specifications.

B.C. Hydro drawings shall have received City or Design Engineer approval prior to the commencement of construction.

Prior to commencement of work near energized overhead hydro as defined in WCB regulation – Part 19, the contractor shall complete a WorkSafe BC Form 30M33.

#### **9.3 Telecommunications**

Telecommunication servicing shall be designed in accordance with the material specifications of the applicable telecommunication operator and shall be compatible with all other underground utilities.

Telecommunication drawings shall have received City or Design Engineer approval prior to the commencement of construction.

#### **9.4 Gas Distribution System**

Gas distribution system shall be designed in accordance with the material specifications of the applicable Gas distribution operator and shall be compatible with all other underground utilities.

Gas distribution system drawings shall have received City or Design Engineer approval prior to the commencement of construction.

### **B. MATERIALS**

Hydro, Telecommunications and Gas materials shall be supplied in accordance with the applicable utility provider's standards.

### **C. INSTALLATION**

Hydro, Telecommunications and Gas installation shall be in accordance with the applicable utility provider's standards.

### **D. TESTING**

Hydro, Telecommunications and Gas testing shall be in accordance with the applicable utility provider's standards.

---

## **10.0 LANDSCAPING**

### **A. DESIGN CRITERIA**

#### **10.1 General**

Where provisions of the Subdivision and Development Servicing Bylaw No. 4293 require the construction of an irrigation system or vegetative planting, the applicant shall construct the works consistent with the regulations, standards and specifications set out in this schedule.

#### **10.2 Approval Drawings**

Engineering drawings showing the detailed design of the landscaping shall be submitted to the City Engineering Department for approval prior to commencement of construction. These drawings shall show basic road and lot network, location of all shallow utilities and above ground appurtenances (manhole lids, IC chambers, hydrants, transformers, street lights, etc.), location of the irrigation lines and appurtenances, the size, location and type of all plantings, topsoil depths, seeding locations and mixes.

The drawings shall conform to the City of Salmon Arm's Landscape Standards and Recommended Species Guide which are available from the City upon request.

#### **10.3 Boulevards**

Boulevards which are not required to be landscaped and irrigated shall be provided with a minimum of 300mm of topsoil and either hydro seeded or sodded. Alternative landscaping may be approved at the discretion of the City Engineer. Owner/ =Developer shall be responsible for proper care and maintenance of boulevard for entirety of 1 year maintenance period or until change of ownership of responsible parcel.

The minimum width for grass boulevards shall be 1.0m. Where a separated sidewalk at a distance less than 1.0m is unavoidable the area should either be additional concrete area, or decorative stone placed over a woven fabric weed barrier.

Hydroseeding and seeding within boulevards to conform to the approved materials list seed blend.

#### **10.4 Hydroseeding**

Disturbed areas that are not to be otherwise landscaped shall be hydroseeded where the slope is less than 10%. Hydroseeding in conjunction with erosion matting or other ESC controls shall be used where the slope is greater than 10%.

#### **10.5 Sodding**

Disturbed areas that are not to be otherwise landscaped shall be sodded where adjacent to existing dwellings/facilities. Sodded areas shall require

---

**10.6 Seeding**

Seeding is discouraged, but may be permitted by the City Engineer in areas that are low use and low risk for erosion.

**10.7 Irrigation**

Irrigation of the boulevards is required for all medium and high density residential developments and all Industrial/Commercial/Institutional developments.

Where the sidewalk is separated from the curb in residential areas, irrigation sleeves shall be installed, one per lot, and the location marked on the sidewalk by stamping the wet concrete with an arrow.

All infrastructure (i.e. sprinkler heads) to be installed a minimum of 5mm below the finished sidewalk grade, or in another manner to minimize damage during snow clearing procedures.

All irrigation services to have appropriate backflow prevention in accordance with the City's current Cross Connection Control Bylaw.

**10.8 Street Trees**

Street trees shall be installed as required by the City Centre Road Standard. Refer to Specification Drawings RD-5, TRE-1 and TRE-2.

Sufficient un-compacted soil space must be available to accommodate root growth or a soil cells must be provided with sufficient structural capacity to support surrounding infrastructure. Sufficient un-compacted soil space shall be 30 m<sup>3</sup> and minimum 2.5m in each dimension for a single tree or 15 m<sup>3</sup> and minimum 2.0m in each dimension per tree for multiple plantings.

Root barriers shall be installed to the depth of the adjacent City infrastructure.

City shall provide list of approved plantings upon request.

**10.9 Unit Paving**

Unit paving shall be provided to the City Centre Standard. Refer to Specification Drawings RD-5, CGS-13, and CGS-14

---

**B. MATERIALS**

Landscaping materials shall be supplied in accordance with Schedule D – Approved Materials List.

**C. INSTALLATION**

Landscaping installation shall be in accordance with Master Municipal Construction Documents (MMCD) Platinum Edition Volume 2 (The MMCD Association, 2009) as amended, current BCLNA guidelines, and Schedule B – Part 3.

**D. TESTING**

Landscaping testing shall be in accordance with Master Municipal Construction Documents (MMCD) Platinum Edition Volume 2 (The MMCD Association, 2009) as amended and Schedule B – Part 3.

---

## **11.0 HILLSIDE DEVELOPMENT**

### **A. DESIGN CRITERIA**

#### **11.1 General**

Where developments are located within the Hillside Development Area as shown in Schedule A, Map 1 of the Subdivision and Development Servicing Bylaw No. 4293, the design criteria from Schedule B, Sections 1 through 10 shall apply except where amended below.

#### **11.2 Roads**

##### **11.2.1 Single Lane Roadways**

Use of single lane roadways (one-way traffic) may be permitted within an adequate road network where topography warrants. Single lane roadways are intended for single loaded roads and with under 25 units. Exceptions may be granted with approval by the City Engineer. Parking is to be restricted to the right side of the roadway only.

##### **11.2.2 Lanes**

Lanes may be considered where topographic limitations exist. Lanes are intended for single loaded roads and with under 10 units. Exceptions may be granted with approval by the City Engineer.

Lanes within new subdivisions shall conform to Specification Drawing no. RD-12b

##### **11.2.3 Rights-of-ways**

Right of ways may be a minimum of 18.0m for two-lane roadways and 10.0m for one-lane roadways where approved by the City Engineer.

##### **11.2.4 Sidewalks**

Sidewalk locations adjacent to a roadway may meander within the right-of-way where topography warrants and/or be outside of the roadway right-of-way and protected by statutory right-of-way.

##### **11.2.5 Boulevards**

Boulevards may be graded at a slope recommended by a geotechnical engineer. A minimum of 0.5m (low side) or 2.0m (high side) buffer at 2.0% slope towards the roadway must be maintained around all infrastructure or as needed to allow access to and properly support infrastructure.

The hydraulic capacity of the roadway shall be confirmed where part of the overland flow network.

Provisions for snow storage shall be made as required where adequate boulevard space is not provided.

#### 11.2.6 Turn-around

Hammer head turn-around (RD-13) will be permitted where topography prevents installation of full turn around (RD-11).

#### 11.3 **Access**

Driveways on the low side must have a high point a minimum of 0.10m above the adjacent gutter line or as necessary to maintain the hydraulic capacity of the roadway without overflow onto private property.

Driveways shall conform to City of Salmon Arm Policy 3.11 and shall ensure the first 3.5m of the driveway has a grade of no greater than 7.0%.

Shared driveways and private lanes may be permitted where topography warrants, with the following provisions:

- Dead-end lanes shall service no more than six (6) lots and include turn-around provisions.
- Through lanes and shared driveways shall service no more than 15 lots.
- Minimum paved travel lane width shall be 4.0m with widening as necessary to permit safe vehicle movements.
- Land design must allow for access by emergency, garbage collection and moving vehicles at a design speed of 20km/hour.
- No parking shall be allowed on laneways. Guest parking must be accounted for in onsite design.
- For shared driveways, an appropriately sized and located area will be required for common garbage and recycling pick-up from the road.

#### **B. MATERIALS**

Hillside Development materials shall be supplied in accordance with Schedule D – Approved Materials List.

#### **C. CONSTRUCTION**

Hillside Development construction shall be in accordance with Master Municipal Construction Documents (MMCD) Platinum Edition Volume 2 (The MMCD Association, 2009) as amended and Schedule B – Part 3.

#### **D. TESTING**

Hillside Development testing shall be in accordance with Master Municipal Construction Documents (MMCD) Platinum Edition Volume 2 (The MMCD Association, 2009) as amended and Schedule B – Part 3.

# **Subdivision and Development Servicing Bylaw No. 4293**

## **Schedule “B” – Part 2**



## **CITY OF SALMON ARM**

## **SPECIFICATION DRAWINGS**



## Subdivision and Development Servicing Bylaw No. 4293

### Schedule “B”, Part 2 – Standard Drawings

Master Municipal Construction Documents (MMCD) Platinum Edition Volume II (The MMCD Association, 2009) Standard Detail Drawings apply except where removed, replaced or supplemented as indicated below.

Table 2.1 – Standard Drawing Reference

Dwg.	MMCD Drawing Description		Dwg.	CoSA Drawing Description
<b>Concrete and Miscellaneous Details</b>				
C0	Index			
C1	Concrete Sidewalk, Infill and Barrier Curb	Remove		
C2	Concrete Sidewalk and Barrier Curb	Replace	CGS-4a	Separated Standard Sidewalk
C3	Concrete Sidewalk and Rollover Curb	Replace	CGS-4B	Standard Sidewalk
C4	Concrete Curbs – Narrow Base	Replace	CGS-1	Standard High-Back Curb & Gutter
C5	Concrete Curbs – Wide Base	Remove		
C6	Concrete Median Curb and Interim Curbs		CGS-3	Island or Median Curb
C7	Driveway Crossing for Barrier Curbs		CGS-5	Sidewalk Crossing at Driveway Entrance
C8	Wheelchair Ramp for Sidewalk, Infill and Barrier Curbs	Remove		
C9	Wheelchair Ramp for Sidewalk, and Barrier Curbs	Replace	CGS-6	Wheelchair Sidewalk Ramp
C10	Concrete Walkway	Replace	CGS-7	Standard Walkway
C11	Bicycle Baffle			
C12	Removable Restriction Post			
C13	Chain Link Fence for Walkway	Replace	RS-3	Chain Link Fence for Walkway
C14	Handrail on Concrete Retaining Wall			
		Add	CGS-2	Roll-Over Curb & Gutter
		Add	CGS-8	Trail Type 1
		Add	CGS-9	Trail Type 2
		Add	CGS-10	Trail Type 3
		Add	CGS-11	Trail Type 4
		Add	CGS-12	Trail Type 5
		Add	CGS-13	Towncentre Intersection Pedestrian Bulb
		Add	CGS-14	Typical Paver Detail
		Add	RS-1	Reinforced Concrete Stairs

Subdivision and Development Servicing Bylaw No. 4293

Schedule “B”, Part 2 – Standard Drawings

Dwg.	MMCD Drawing Description		Dwg.	CoSA Drawing Description
		Add	RS-2	Sidewalk Railing
<b>Concrete Base</b>				
	CE1.1 – CE1.20			
		Add	SP-1	Typical Sign Post Base
		Add	SL-2	9.00m Davit Concrete Pedestal
		Add	SL-5	5.00m Post Top Concrete Pedestal
<b>Electrical</b>				
	E0.1 – E10.11			
E4.1	Luminaire Pole (Type 2 Shaft)	Replace	SL-1	9.00m Davit Street Lights
E4.2	Luminaire Pole (Type 2 Shaft)			
E4.19	Post Top Luminaire Poles	Replace	SL-3	Post Top Street Light
E4.20	Post Top Luminaire Poles			
E4.21	Service Base			
E4.22	Pole Accessories	Remove		
		Add	SL-3-I	Post Top Street Light with Irrigation & Electrical Outlet
		Add	SL-4	Post Top Street Light/Power Base
		Add	SL-4-I	Post Top Street Light/Power Base with Irrigation & Electrical Outlet
		Add	SL-6	Bracket for Hanging Baskets
<b>General Details</b>				
G0	Index			
G1	General Legend for Contract Drawings	Replace	DD-LG	ANSI ‘D’ Size Legend
G2	Legend for Materials			
G3	Legend for Street Light and Traffic Signal Drawings			
G4	Utility Trench	Replace	UT-1	Typical Utility Trench in Roadway
			UT-2	Typical Utility Trench in Boulevard
G5	Pavement Restoration			
G6	Concrete Encasement for Water Main/Sewer Separation			
G7	Concrete Protection for Underground Utilities			

**Subdivision and Development Servicing Bylaw No. 4293**

**Schedule “B”, Part 2 – Standard Drawings**

Dwg.	MMCD Drawing Description		Dwg.	CoSA Drawing Description
G8	Pipe Anchor Blocks	Replace	UT-3	Anchor Blocks
		Add	DD-PL	ANSI ‘D’ Size Plan Sheet
		Add	DD-PP	ANSI ‘D’ Size Plan/Profile Sheet
		Add	SC-1	Utility Service Card
		Add	UT-4	Utility Main Relocation Details
		Add	UT-5	Trench Dam Detail
		Add	SER-1	Typical Lot Servicing
<b>Roadworks</b>				
R0	Index			
R1	Paved Shoulders			
		Add	RD-1	18m R/W Urban Local Road Cross-Section
			RD-2	20m R/W Urban Local Road Cross-Section
			RD-3	20m R/W Urban Collector Cross-Section
			RD-4	25m R/W Arterial Collector Cross-Section
			RD-5	Town Centre Development Area Road Cross-Section
			RD-6A	Industrial Area Road Cross-Section
			RD-6B	New Industrial Park Cross-Section
			RD-7	20m R/W Rural Local Road Cross-Section
			RD-8	20m R/W Rural Collector Road Cross-Section
			RD-9	25m R/W Rural Arterial Road Cross-Section
			RD-10	18m R/W Urban Cul-de-Sac
			RD-11	20m R/W Urban Cul-de-Sac
			RD-11A	20m R/W Temporary Cul-de-Sac
			RD-11B	10m R/W Temporary Cul-de-Sac
			RD-12A	7.3m R/W Lane
			RD-12B	10.0m R/W Lane Cross-Section
			RD-13	Lane-‘T’ Turn Around
			RD-14	Canoe Beach Drive 20M R/W Road Cross Section (50 <sup>th</sup> Street NE to Park Hill)
			RD-15	18m R/W Urban Local Road Cross-Section (Hillside Development)

**Subdivision and Development Servicing Bylaw No. 4293**

**Schedule “B”, Part 2 – Standard Drawings**

Dwg.	MMCD Drawing Description		Dwg.	CoSA Drawing Description
			RD-16	12m R/W Urban Single Lane Local Road Cross-Section (Hillside Development)
<b>Storm and Sanitary Sewer</b>				
S0	Index			
S1	Standard and Sump Manholes	Replace	SAN-1	Typical 1050mm Sanitary Manhole
			ST-2	Typical 1050mm Storm Manhole
S2	Standard Manhole Connection Details	Remove		
S3	Manhole Connection Details – Drop and Ramp Type	Replace	SAN-3	Typical 1050mm Sanitary Drop Manhole
S4	Inside Drop Manhole	Remove		
S5	Precast Riser Manhole			
S6	Sewer Clean-out			
S7	Sanitary Sewer Service Connection	Replace	SAN-4	Typical 100mm Sanitary Service Connection
S8	Storm Sewer Service Connection	Replace	ST-4	Typical 150mm Storm Service Connection
S9	Inspection Chamber for 100 to 200 Sanitary Sewer Connection	Replace	SAN-6	Inspection Chamber for Sanitary Connection
S10	Inspection Chamber for 250 to 375 Storm Sewer Connection	Replace	ST-6	Inspection Chamber for Storm Connection
S11	Top Inlet Catchbasin	Replace	ST-1A & ST-1B	Precast Reinforced Concrete Catchbasin
S12	Lawn Drains			
S13	Storm Sewer Inlet with Safety Grillage	Replace	ST-8	Typical Cast in Place Inlet Structure (250 to 600mm dia. Storm Pipe)
S14	Concrete Block Endwall	Replace	ST-9	Concrete Block Inlet/Outlet Structure (250 to 600mm dia. Storm Pipe)
S15	Driveway Culvert with Concrete Block Endwalls			
		Add	SAN-2	H-20 Manhole Frame & Cover (Sanitary)
		Add	ST-3	H-20 Manhole Frame & Cover (Storm)
		Add	SAN-7	Air Release Valve – Forcemain
		Add	SAN-8	Sanitary Dump Station
		Add	ST-5	Manhole Requirements for Storm Sewer Services

**Subdivision and Development Servicing Bylaw No. 4293**

**Schedule “B”, Part 2 – Standard Drawings**

Dwg.	MMCD Drawing Description		Dwg.	CoSA Drawing Description
		Add	ST-7	Rainfall Intensity-Duration Data
		Add	ST-10	Typical Concrete Outlet Structure (250 to 1050mm dia. Storm Pipe)
		Add	ST-11	Safety Grillage fro Inlet/Outlet Structure
		Add	ST-12	Twin Inlet Catch Basin Frame
		Add	ST-13	Typical Drainage Drywell
		Add	ST-14	Typical Catch Basin Drywell
		Add	ST-15	Storm Sewer Design Sheet
		Add	SAN-9	Sanitary Sewer Design Sheet
		Add	ST-16	Typical 1050mm Storm Drop Manhole
<b>Waterworks</b>				
W0	Index			
W1	Typical Thrust Block Arrangements	Replace	W-1	Thrust Block Details
W2a	Water Service Connection – Service Box	Replace	W-2	Typical 25mm Water Service Connection
W2b	Water Service Connection – Valve Box			
W2c	Meter Installation – For 19mm and 25mm services	Replace	W-10	Residential Water Meter
W2d	Meter Installation – For 38mm and 50mm Service Connection	Replace	W-11	Commercial Water Meter
W3	Gate Valve Installation	Replace	W-5	Standard Valve Box
W4	Fire Hydrant Installation	Replace	W-3	Fire Hydrant Assembly
W5	Test Point Installation			
W6	Air Valve Assemblies – 25mm and 50mm Valves	Replace	W-6	Air Release Valve (100 to 500mm dia. watermain)
W7	Air Valve Assembly - 100mm Valve	Replace	W-7	Air Release Valve (600 to 1200mm dia. watermain)
W8	Blow-Off-For Watermain	Replace	W-4	Typical Blow-off Assembly
W9	Blow-Down Chamber			
W10	Waterworks Chamber Drain			
		Add	W-8	H-20 Manhole Frame & Cover
		Add	W-9	Fire Service Water Vault/Meter Detail
		Add	W-12	Pit Setter
<b>Cathodic Protection</b>				

**Subdivision and Development Servicing Bylaw No. 4293**

**Schedule “B”, Part 2 – Standard Drawings**

<b>Dwg.</b>	<b>MMCD Drawing Description</b>		<b>Dwg.</b>	<b>CoSA Drawing Description</b>
W100	Index			
W104	Ground Level Test Station Details			
W105	Big Fink Test Station Terminal			
W106	Joint Continuity Bond			
W107	Wire Fastening Detail			
W108	Standard Test Station			
W109	Isolation Test Station			
W110	Sacrificial Anode Station at Isolation Test Point			
W111	Standard Sacrificial Anode Station			
W112	Sacrificial Anode Station with Lateral or Service Connection			
W113	Foreign Utility Test Station			
W114	Impressed Current Cathodic Protection Rectifier Installation			
W115	Horizontal Anode Installation			
W116	Semi-Deep Anode Well Installation			
W119	Fire Hydrant Installation for HDPE Pipe			
<b>Landscape</b>				
		Add	TRE-1	Typical Double Tree Stakes (for trees over 2m high)
		Add	TRE-2	Typical Tree (with Grate, Guard and Receptacle)

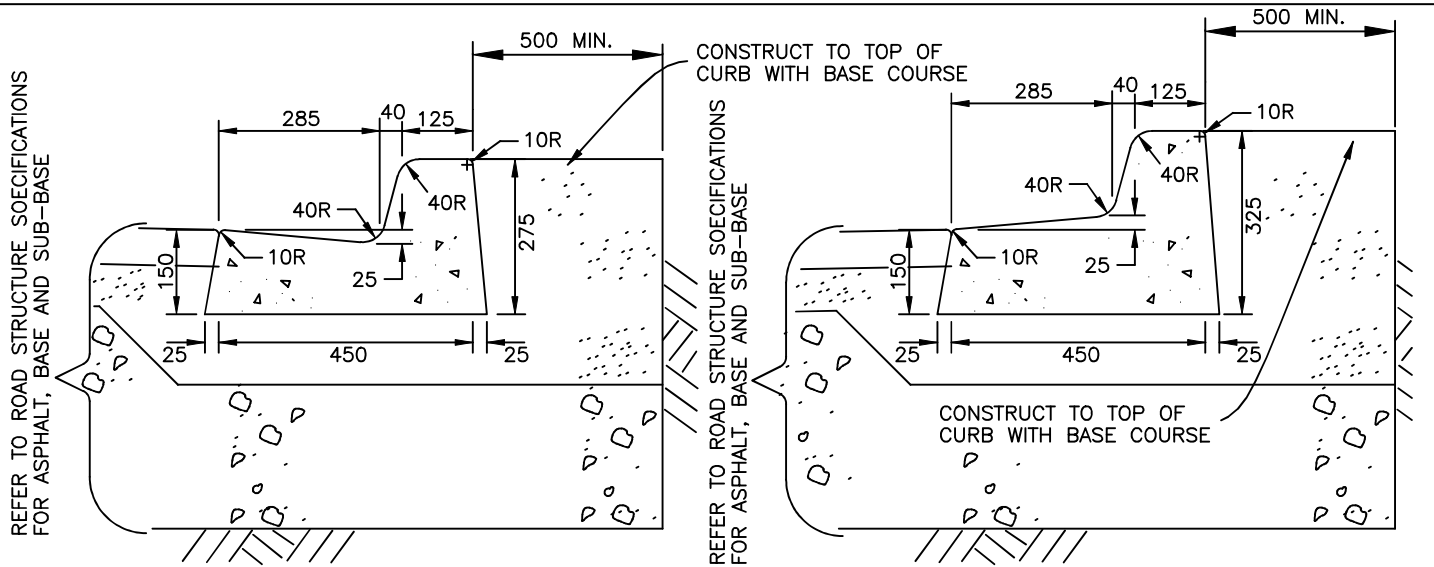

HIGH-BACK CURB & GUTTER

REVERSE GRADE HIGH-BACK CURB & GUTTER

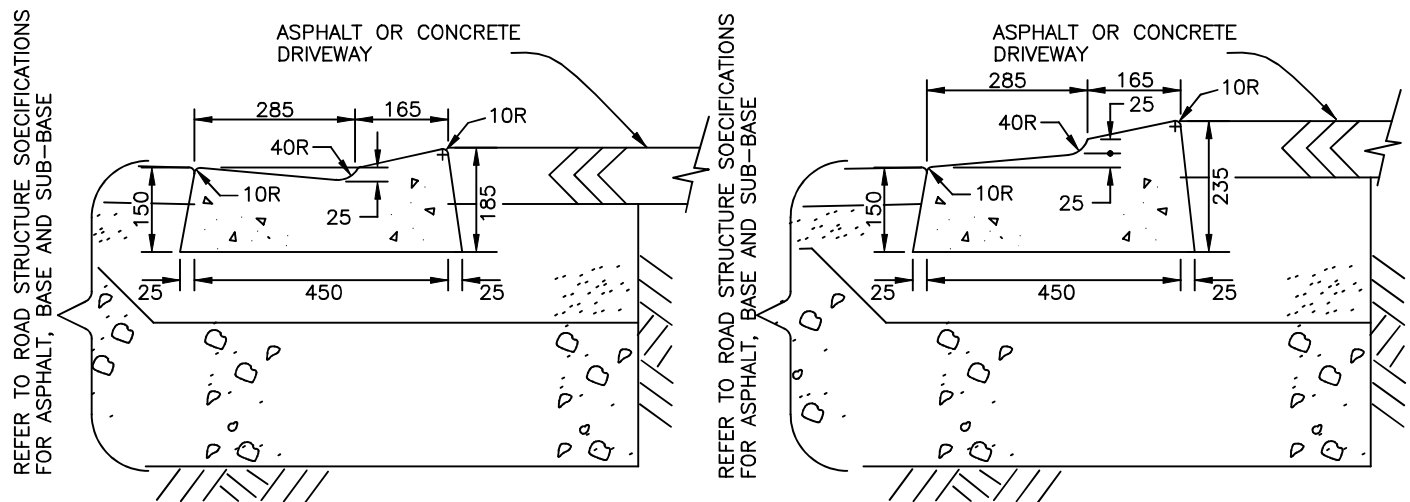

HIGH-BACK CURB & GUTTER AT LETDOWN CROSSING

REVERSE GRADE HIGH-BACK CURB & GUTTER AT LETDOWN CROSSING

NOTES:

- 1) Control joints shall be cut & tooled into the concrete to a depth of 60% of the thickness of the concrete at intervals of 3.0m.

<b>CITY OF SALMON ARM</b>		APPROVED		STANDARD HIGHBACK CURB AND GUTTER
No.	REVISION	Date		
A	APPROVED	10/11/16	CGS-1	
B	SDSB 4293 REV'S - ISSUED FOR APPROVAL	26/06/23		

REFER TO ROAD STRUCTURE SPECIFICATIONS FOR ASPHALT, BASE AND SUB-BASE

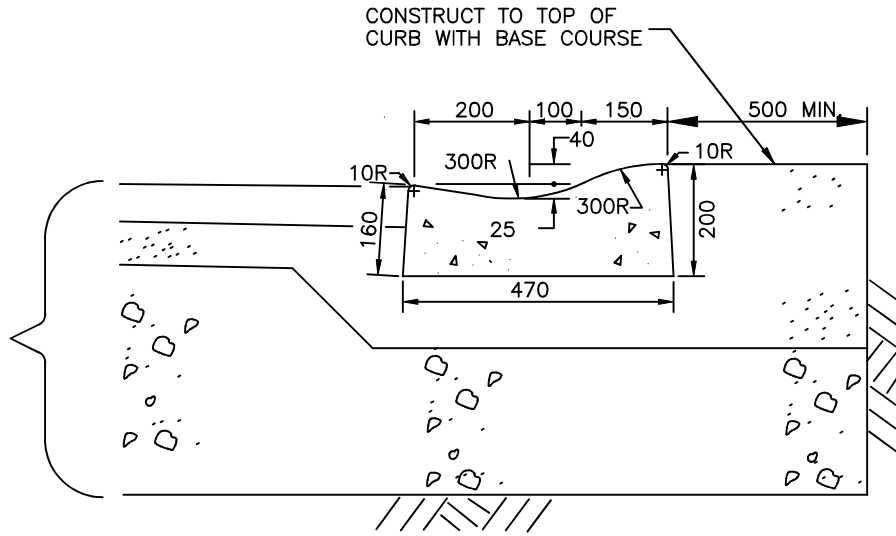

ROLL-OVER CURB & GUTTER

REFER TO ROAD STRUCTURE SPECIFICATIONS FOR ASPHALT, BASE AND SUB-BASE

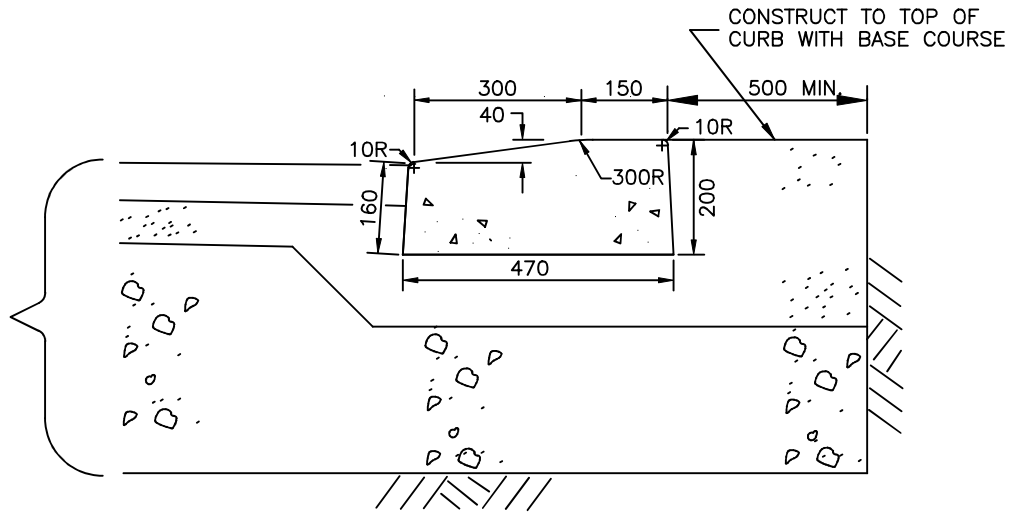

REVERSE GRADE ROLL-OVER CURB & GUTTER

NOTES:

- Control joints shall be cut & tooled into the concrete to a depth of 60% of the thickness of the concrete at intervals of 3.0m.

**CITY OF SALMONARM**

No.	REVISION	Date
A	SDSB 4293 – ISSUED FOR APPROVAL	06/12/23

APPROVED



ROLL-OVER CURB & GUTTER

SPECIFICATION  
DRAWING No.:

CGS-2



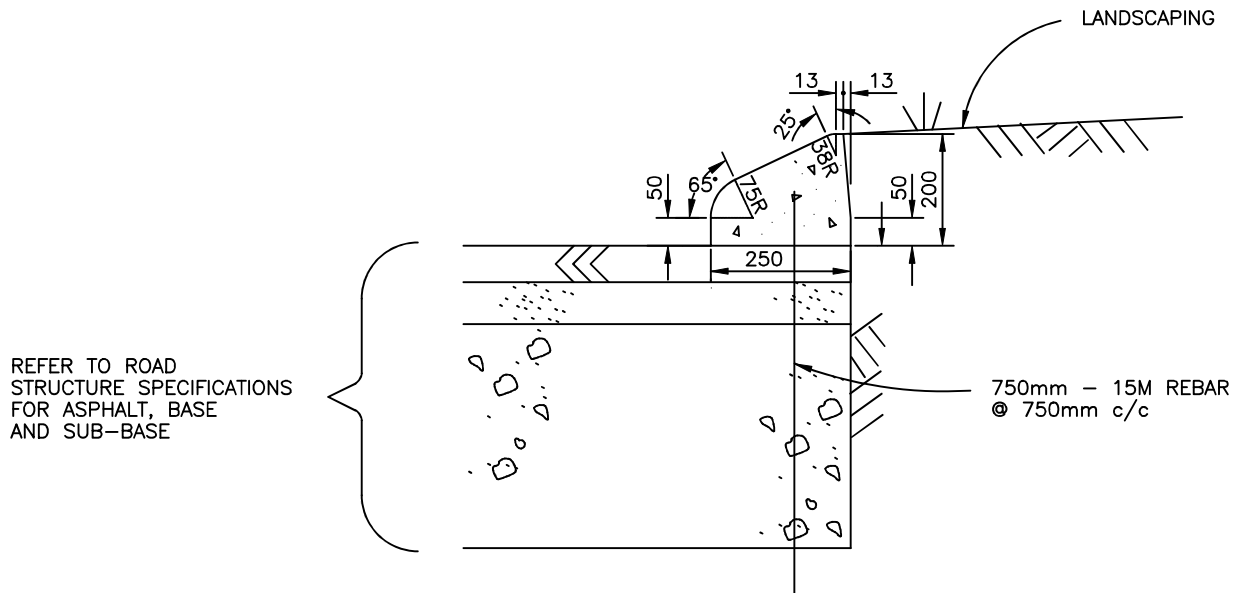

**NOTES:**

- 1) 750mm – 19Ø Dowels every 750mm.
- 2) Control joints shall be cut & tooled into the concrete to a depth of 60% of the thickness of the concrete at intervals of 3.0m.

**CITY OF SALMON ARM**

No.	REVISION	Date
A	SDSB 4293 – ISSUED FOR APPROVAL	06/12/23

APPROVED



ISLAND OR MEDIAN CURB

SPECIFICATION  
DRAWING No.:

CGS-3

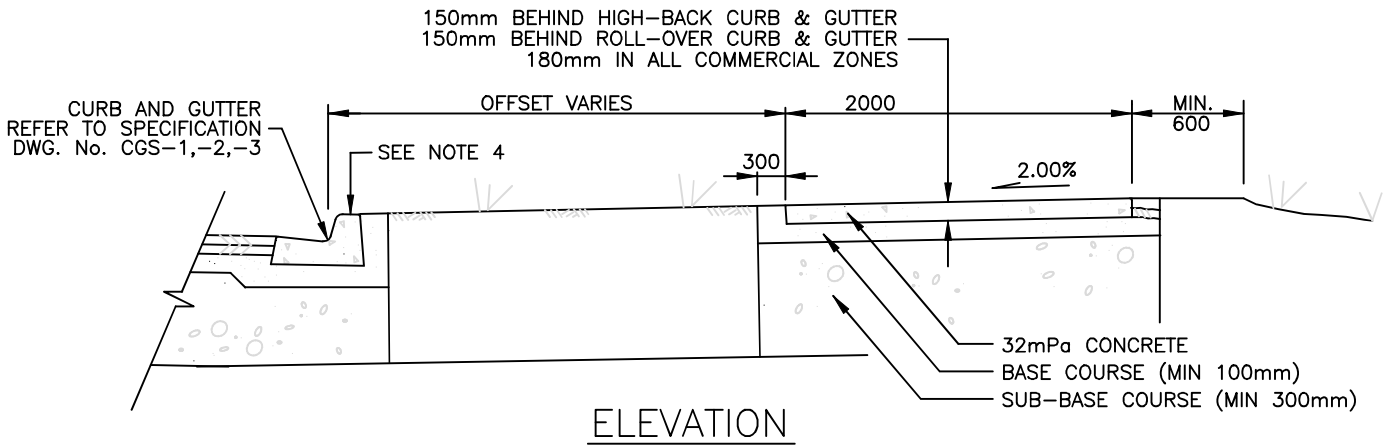
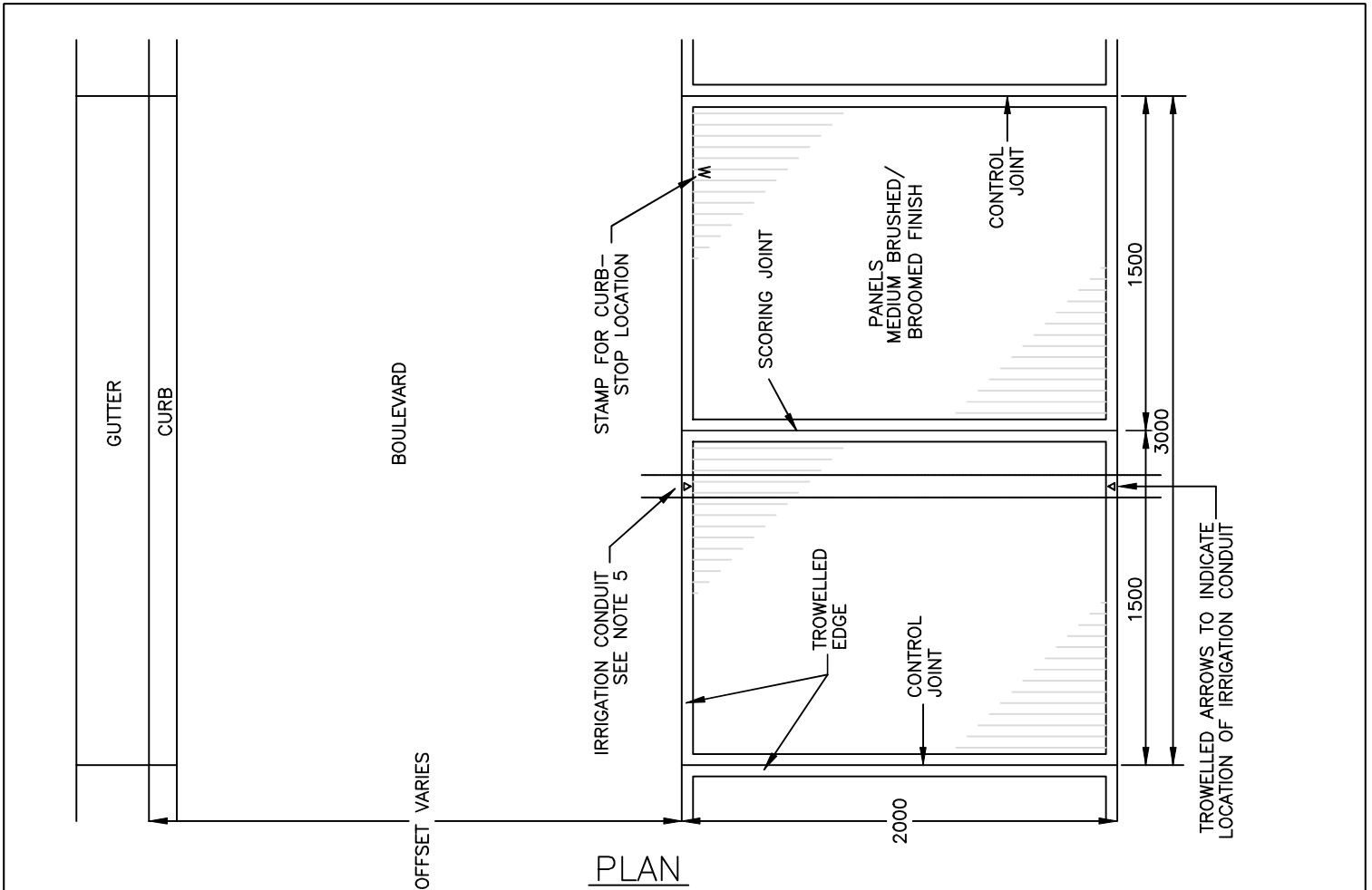

**NOTES:**

- 1) Control joints shall be cut to 60% depth of the concrete and trowelled 5mm wide, 15mm deep at 3.0m spacing.
- 2) Scoring joints shall be 5mm wide and 15mm deep.
- 3) Trowelled edges shall be 30mm wide.
- 4) Refer to CGS-5 for Driveway Crossings.
- 5) Where sidewalk is separated from roadway with boulevard Driveway aprons to be concrete between sidewalk & curb.

<b>CITY OF SALMONARM</b>		
No.	REVISION	Date
A	SDSB 4293 – ISSUED FOR APPROVAL	06/12/23

APPROVED

STANDARD SEPARATED  
SIDEWALK

SPECIFICATION  
DRAWING No.:

CGS-4A

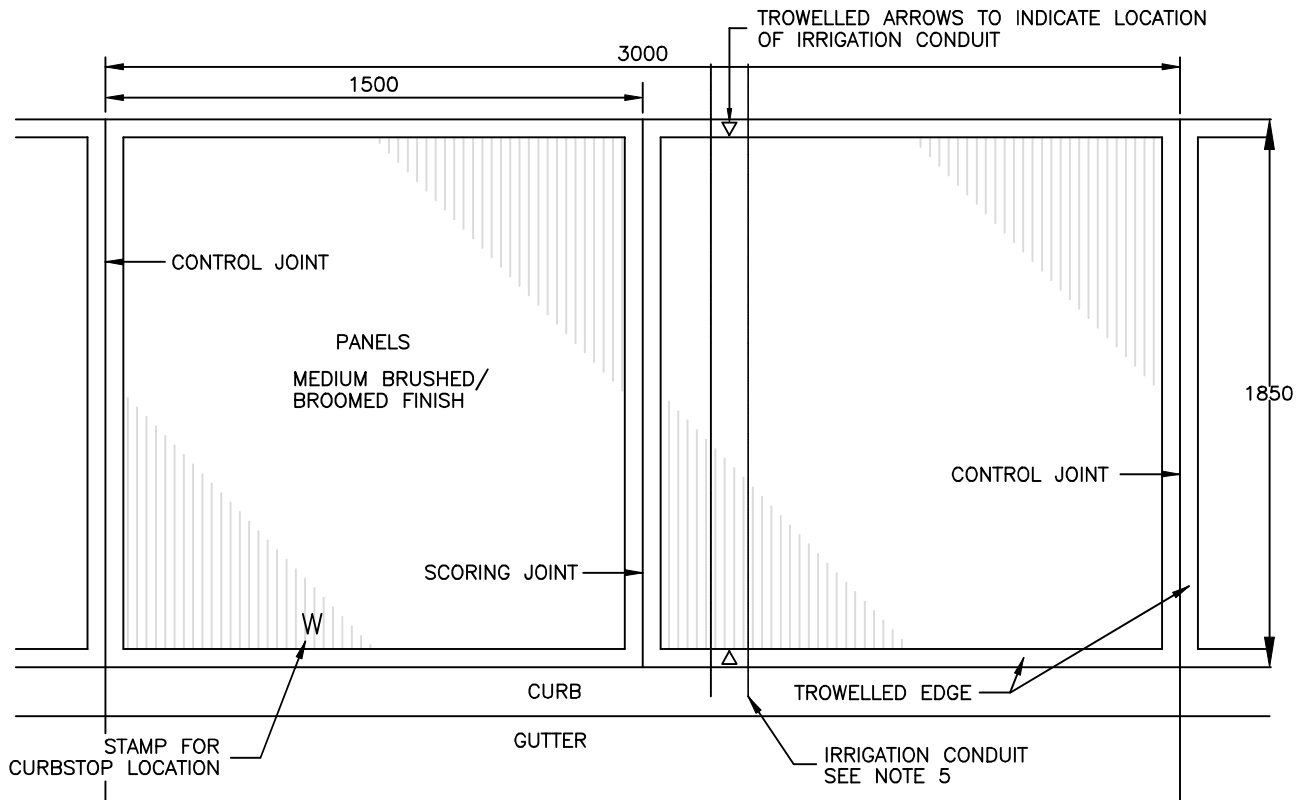

PLAN

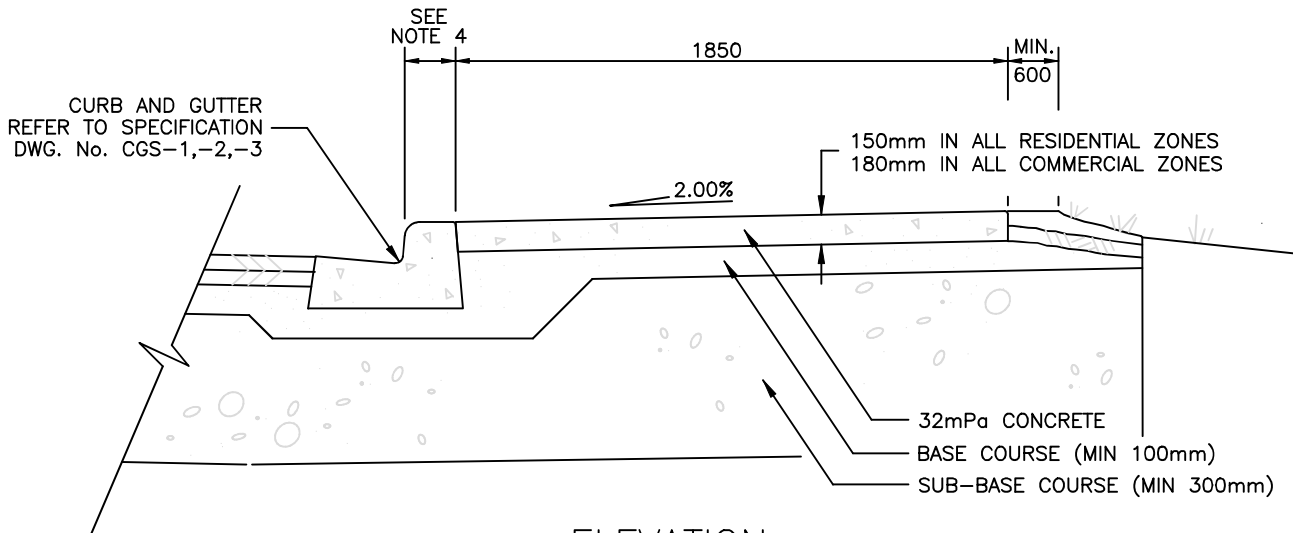

ELEVATION

NOTES:

- 1) Control joints shall be cut to 60% depth of the concrete and trowelled 5mm wide, 15mm deep at 3.0m spacing.
- 2) Scoring joints shall be 5mm wide and 15mm deep.
- 3) Trowelled edges shall be 30mm wide.
- 4) Refer to CGS-5 for Driveway Crossings.
- 5) Where sidewalk is separated from roadway with boulevard. Driveway aprons to be concrete between sidewalk & curb.

**CITY OF SALMON ARM**

No.	REVISION	Date
A	SDSB 4293 – ISSUED FOR APPROVAL	06/12/23

APPROVED



STANDARD SIDEWALK

SPECIFICATION  
DRAWING No.:

CGS-4B

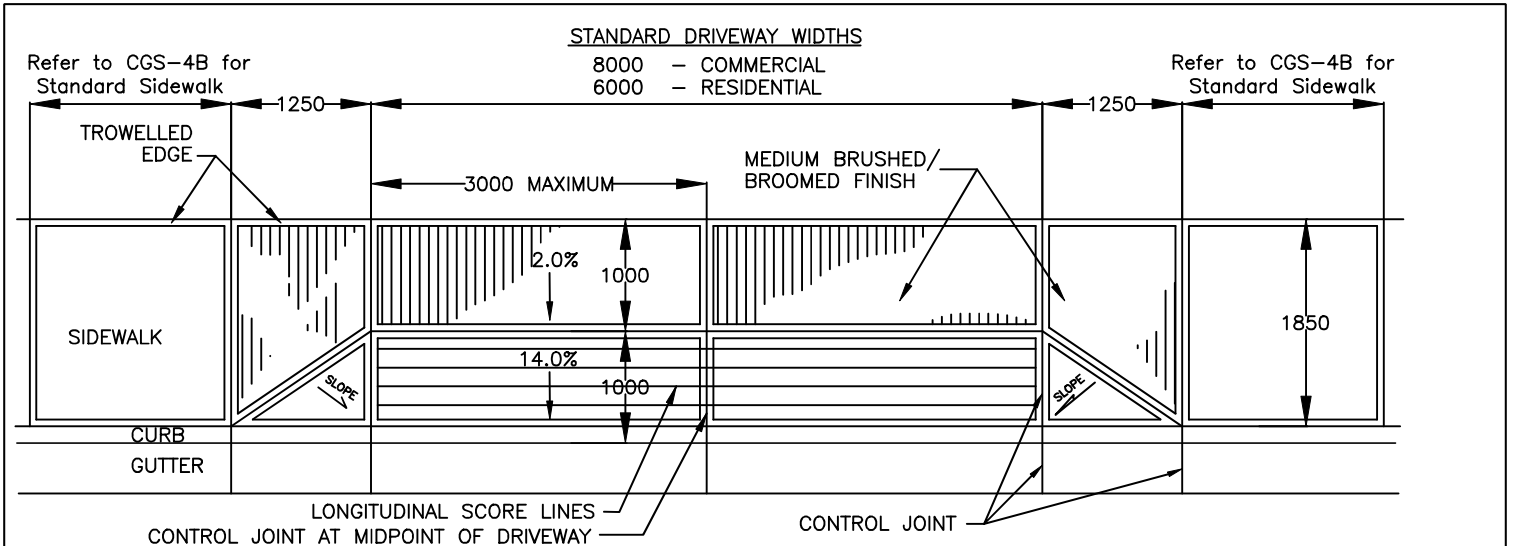

PLAN – NON-SEPARATED SIDEWALK

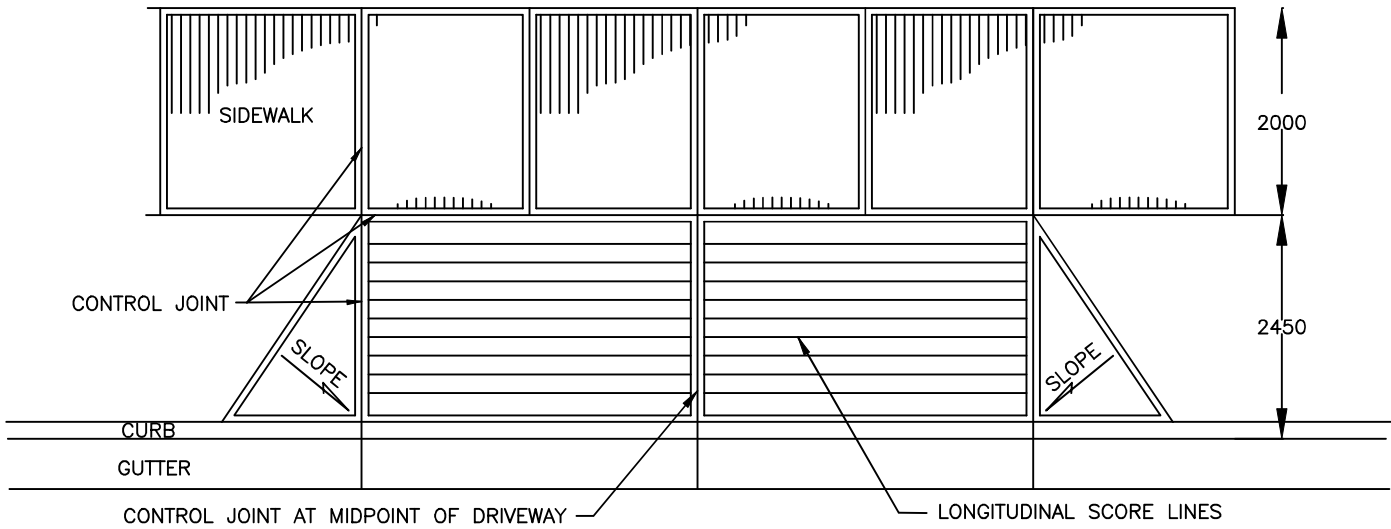

ELEVATION

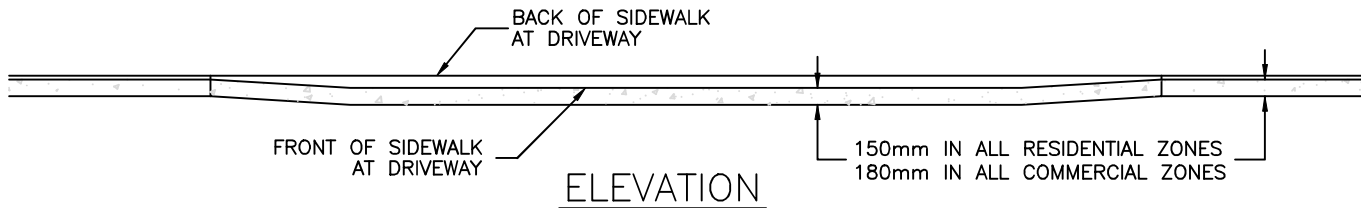

**NOTES:**

- 1) Control joints shall be cut to 60% depth of the concrete and trowelled 5mm wide, 15mm deep in 150mm driveway slab. Curb and gutter to a depth of 60% the thickness of the concrete.
- 2) Scoring joints shall be 5mm wide and 15mm deep and are required where control joints exceed 2.0m spacing.
- 3) Trowelled edges shall be 30mm wide.
- 4) Maximum Driveway widths shall be 10.0m for Commercial Driveways and 8.0m for residential driveways (maximum 50% of lot frontage). City Engineer approval is necessary for use of non-standard driveway widths.

<b>CITY OF SALMONARM</b>		
No.	REVISION	Date
A	SDSB 4293 – ISSUED FOR APPROVAL	06/12/23

APPROVED

STANDARD CROSSING AT DRIVEWAY ENTRANCE

SPECIFICATION DRAWING No.: CGS-5

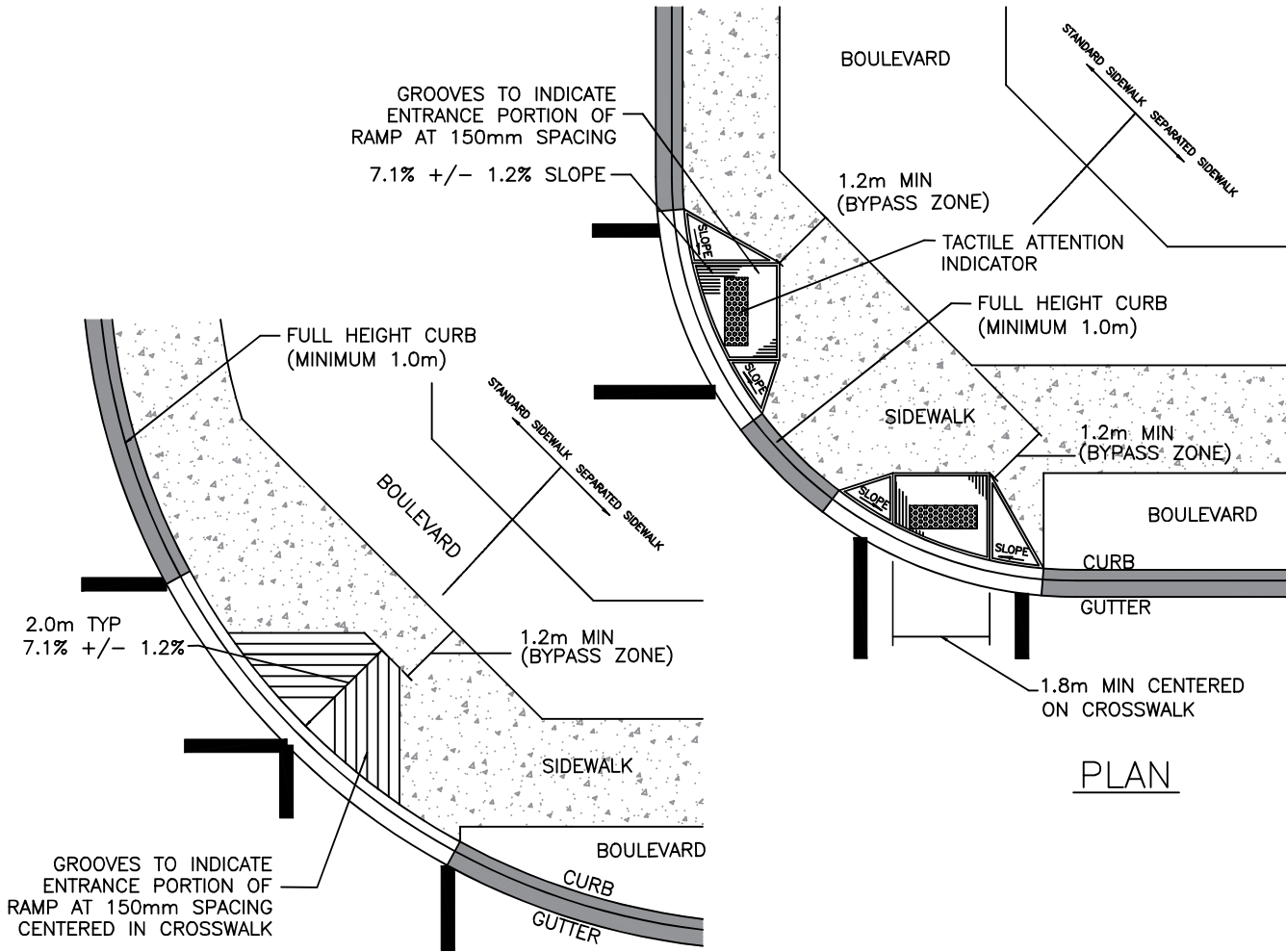

PLAN

PLAN

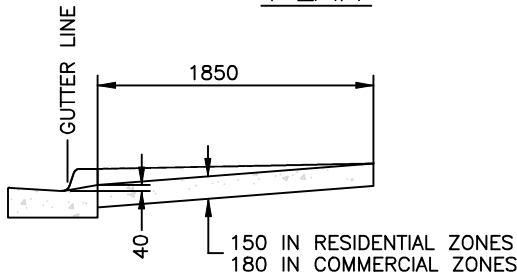

STANDARD CURB AND GUTTER SECTION DETAIL

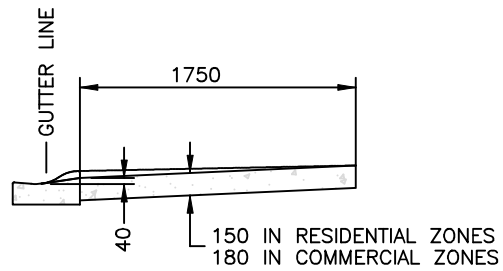

ROLL-OVER CURB AND GUTTER SECTION DETAIL

NOTES:

1. Control joints shall be installed per the specification in Standard Drawing CGS-4A
2. Tactile Attention Indicators shall be used in high traffic areas as determine by the City Engineer.
3. Tactile Attention Indicators should extend the full width of the curb ramp and should start between 300 and 350 millimeters from the road face of the curb.

**CITY OF SALMON ARM**

No.	REVISION	Date
A	SDSB 4293 – ISSUED FOR APPROVAL	06/12/23

APPROVED



WHEELCHAIR SIDEWALK RAMP

SPECIFICATION DRAWING No.:

CGS-6

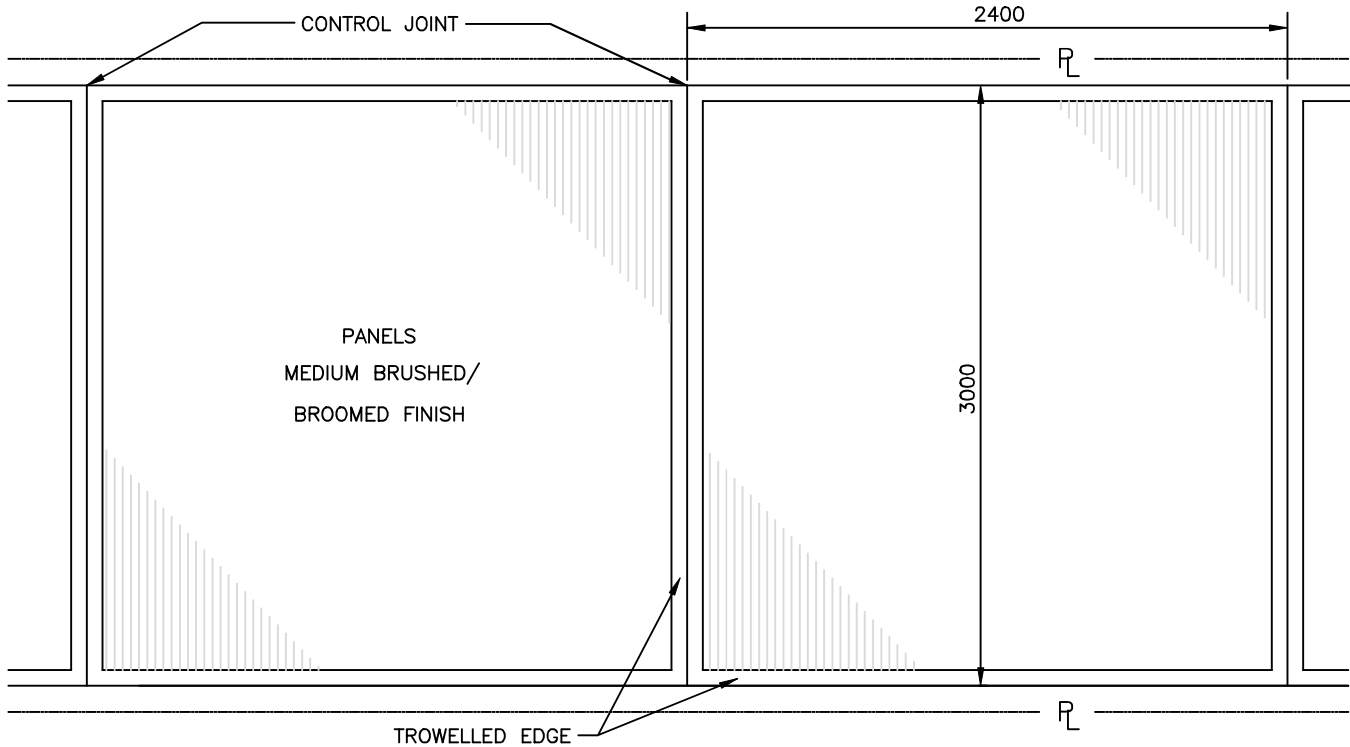

PLAN

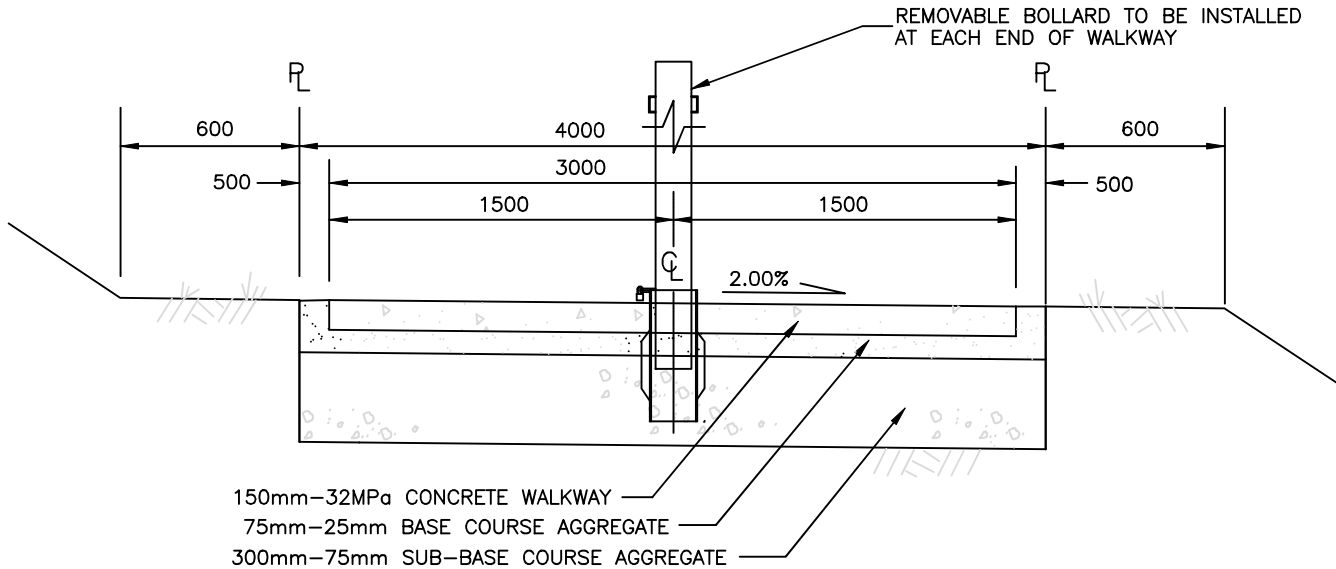

ELEVATION

NOTES:

- 1) Control joints shall be cut to 60% depth of the concrete and trowelled 5mm wide, 15mm deep in 150mm driveway slab. Curb and gutter to a depth of 60% the thickness of the concrete.
- 2) Scoring joints shall be 5mm wide and 15mm deep and are required where control joints exceed 2.0m spacing.
- 3) Trowelled edges shall be 30mm wide.

**CITY OF SALMON ARM**

No.	REVISION	Date
A	SDSB 4293 – ISSUED FOR APPROVAL	06/12/23

APPROVED



STANDARD WALKWAY

SPECIFICATION  
DRAWING No.:

CGS-7

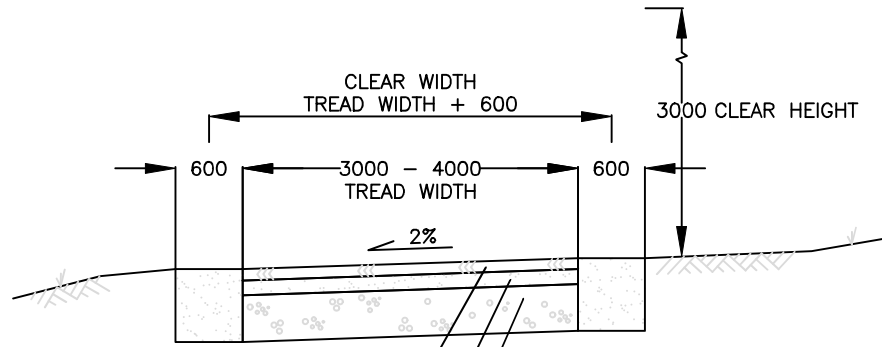

MINIMUM 50mm – ASPHALT CONCRETE PAVEMENT  
 MINIMUM 75mm – 25mm CRUSHED BASE COURSE AGGREGATE  
 MINIMUM 300mm – 75mm  
 SCREENED OR CRUSHED SUB-BASE COURSE AGGREGATE

ELEVATION

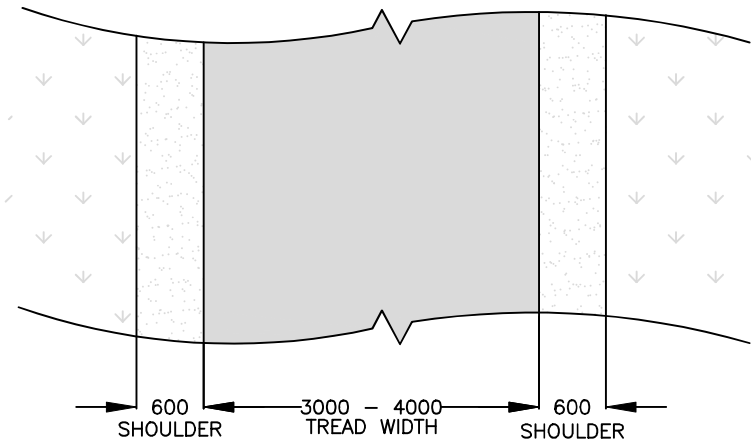

PLAN VIEW

NOTES:

- 1) Trail designed for high use
- 2) Beginner to intermediate user group
- 3) Base and tread materials shall be imported
- 4) Tread surface shall be cross-fall or crowned
- 5) ditching and culverts required for surface drainage
- 6) Base layers shall be below original ground, tread surface shall be near to original ground elevation

**CITY OF**  
**SALMONARM**

No.	REVISION	Date
A	SDSB 4293 – ISSUED FOR APPROVAL	06/12/23

APPROVED



TRAIL TYPE 1 (MULTI-USE  
 PATH)

SPECIFICATION  
 DRAWING No.:

CGS-8

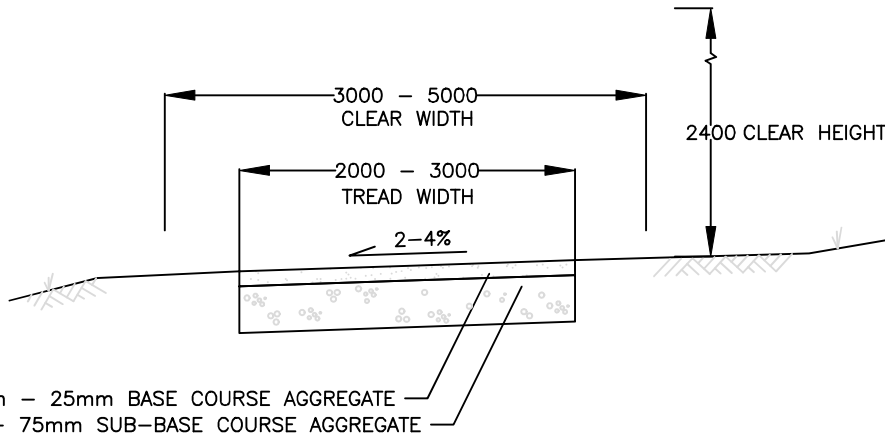

ELEVATIONS

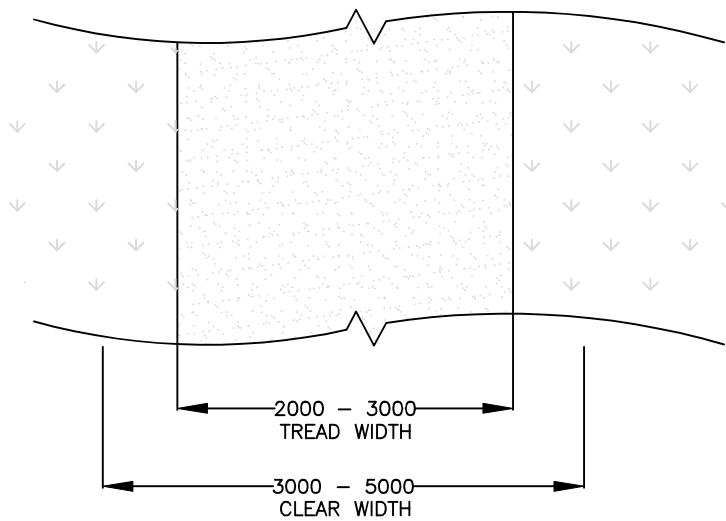

PLAN VIEW

NOTES:

- 1) Trail designed for regular to high use
- 2) Beginner to intermediate user group
- 3) Base and tread materials shall be imported
- 4) Tread surface shall be crowned or cross-fall
- 5) ditching and culverts required for surface drainage
- 6) Base layers shall be below original ground, tread surface shall be near to original ground elevation

**CITY OF**  
**SALMONARM**

No.	REVISION	Date
A	SDSB 4293 – ISSUED FOR APPROVAL	06/12/23

APPROVED



TRAIL TYPE 2

SPECIFICATION  
DRAWING No.:

CGS-9



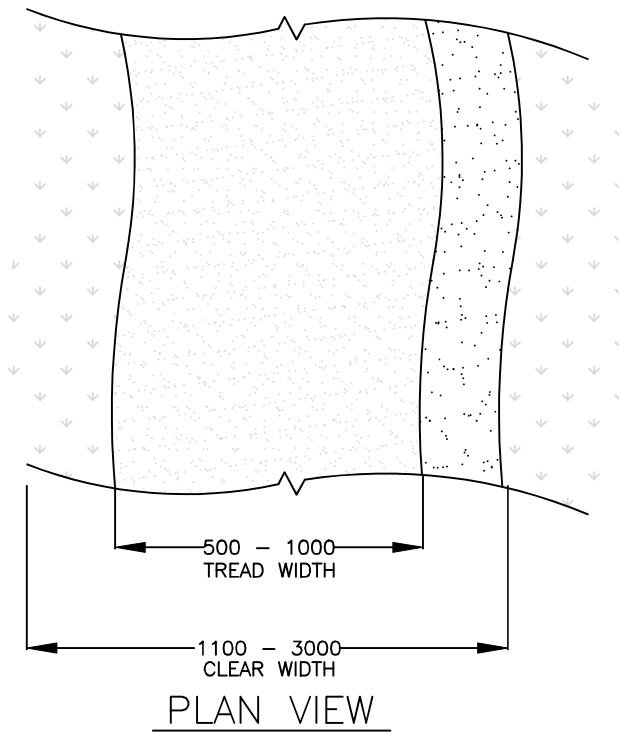
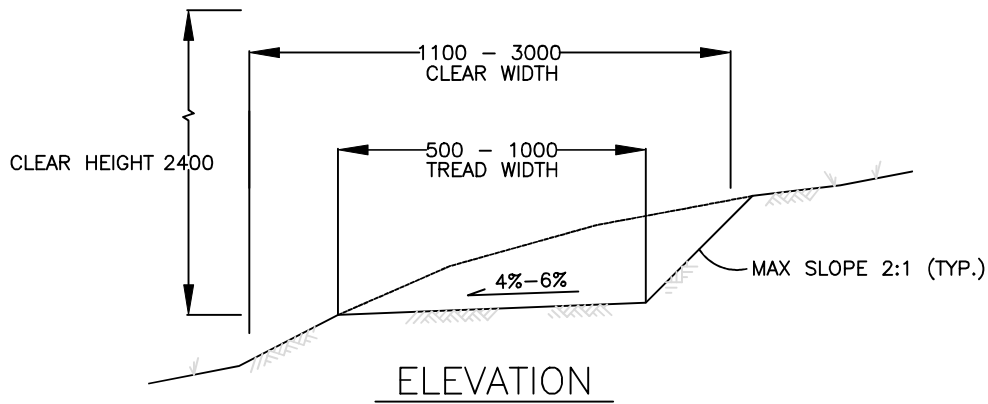

**NOTES:**

- 1) Trail designed for regular use
- 2) Beginner to advanced user group
- 3) Roots and rocks shall be removed from tread surface
- 4) Tread surface shall be of compacted native material
- 5) Grades in excess of 2H:1V shall be recommended by a geotechnical engineer and approved by the City Engineer.

**CITY OF SALMONARM**

No.	REVISION	Date
A	SDSB 4293 – ISSUED FOR APPROVAL	06/12/23

APPROVED



TRAIL TYPE 3

SPECIFICATION DRAWING No.:

CGS-10

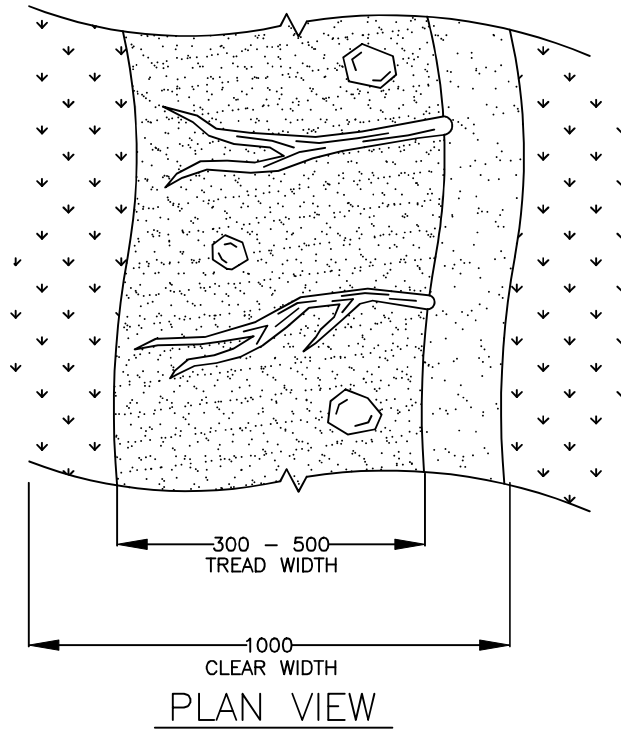
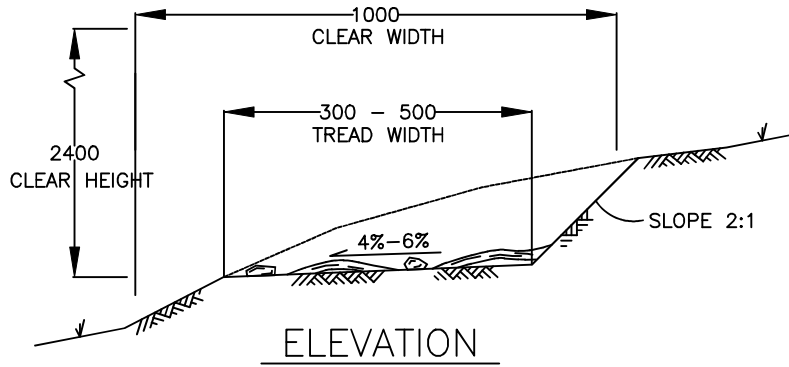

NOTES:

- 1) Trail designed for moderate to low use
- 2) Intermediate to advanced user group
- 3) roots and rocks may remain in tread surface
- 4) Tread surface shall be of native material
- 5) Roots shall run perpendicular to trail direction
- 6) Rocks left in tread shall be smooth and only left in tread if necessary
- 7) Large roots should be covered to protect them from damage
- 8) Grades in excess of 2H:1V shall be recommended by a geotechnical engineer and approved by the City Engineer.

<b>CITY OF SALMON ARM</b>		
No.	REVISION	Date
A	SDSB 4293 – ISSUED FOR APPROVAL	06/12/23

APPROVED

TRAIL TYPE 4

---

SPECIFICATION DRAWING No.: CGS-11

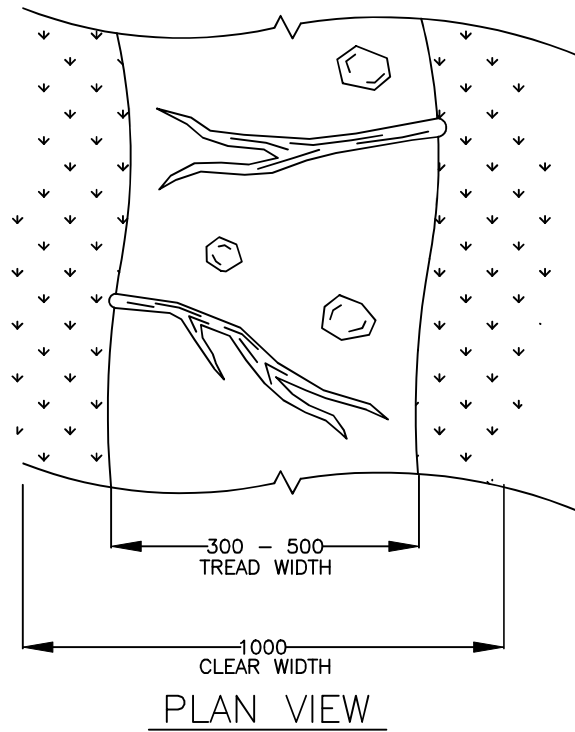
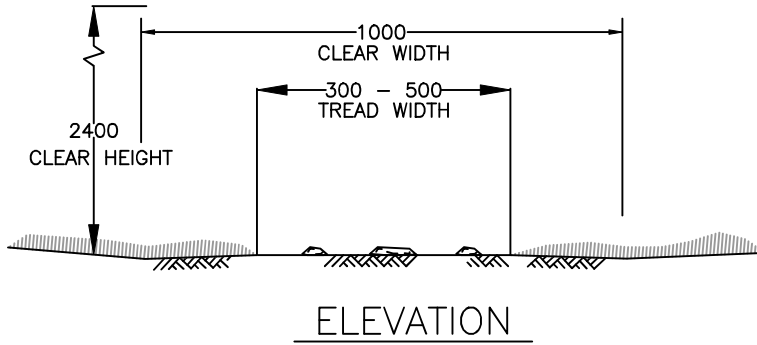

NOTES:

- 1) Trail designed for low use and low impact
- 2) Intermediate to advanced user group
- 3) roots and rocks may remain in tread surface
- 4) NOT for equestrian or motorized use
- 5) Avoid grubbing of trail, tread surface shall be created by natural wear of the native surface material
- 6) Boardwalks shall be used for highly sensitive areas

**CITY OF**  
**SALMONARM**

No.	REVISION	Date
A	SDSB 4293 – ISSUED FOR APPROVAL	06/12/23

APPROVED



TRAIL TYPE 5

SPECIFICATION  
DRAWING No.:

CGS-12



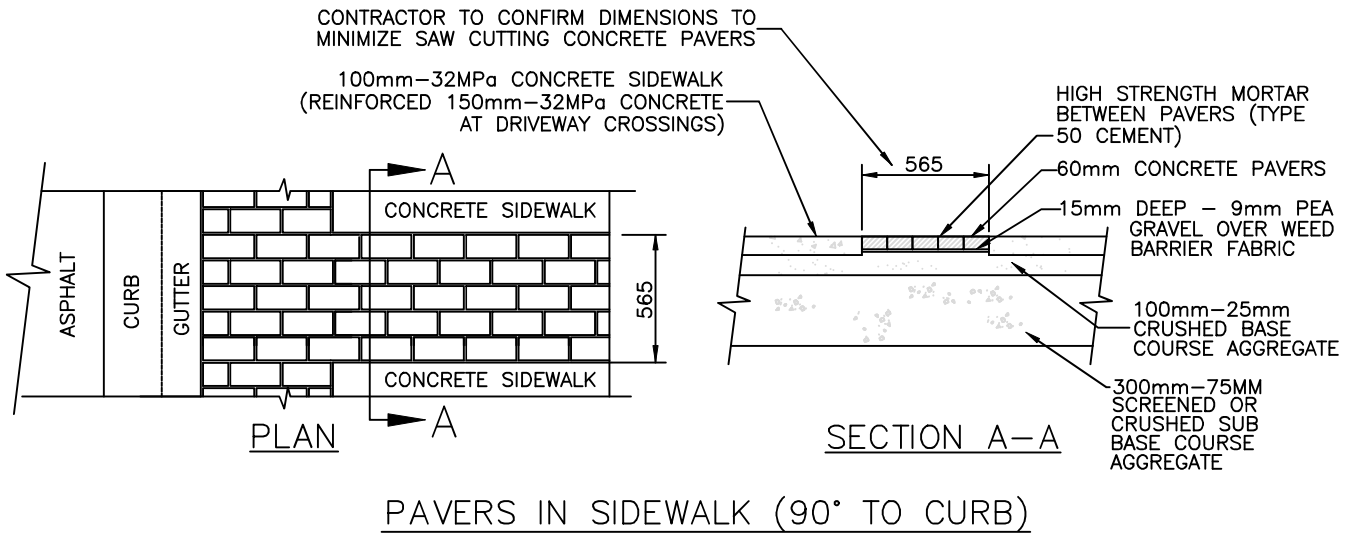
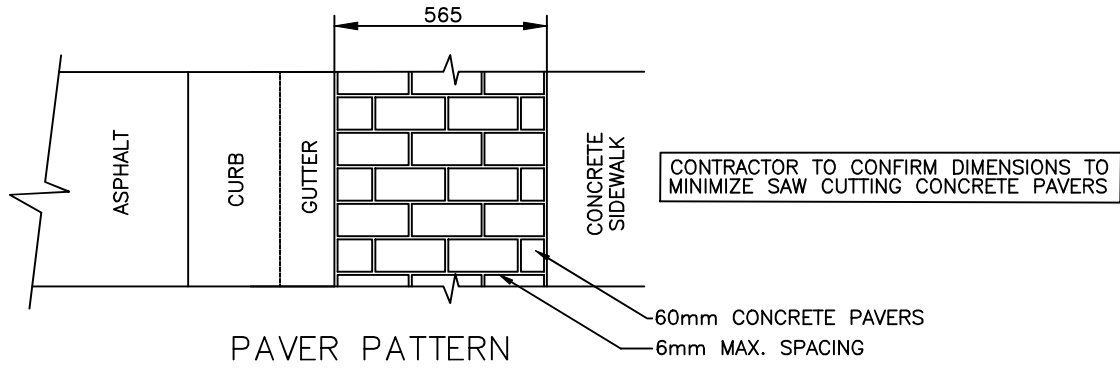

**CITY OF SALMON ARM**

No.	REVISION	Date
A	SDSB 4293 – ISSUED FOR APPROVAL	06/12/23

APPROVED



TYPICAL PAVER DETAIL

SPECIFICATION  
DRAWING No.:

CGS-14

LEGEND

EXISTING

- HYDRO/TELEPHONE POLE
- HYDRO/TELEPHONE POLE C/W DAVIT
- TELEPHONE POLE
- HYDRO POLE
- HYDRO POLE C/W TRANS.
- POST TOP STREET LIGHT
- GUY
- SANITARY MANHOLE
- STORM MANHOLE
- CATCHBASIN
- FIRE HYDRANT
- GATE VALVE
- SANITARY SEWER
- STORM MAIN
- FORCE MAIN
- WATER MAIN
- GAS
- UNDERGROUND TELEPHONE
- FENCE
- DECIDUOUS/EVERGREEN

PROPOSED

- SANITARY MANHOLE
- STORM MANHOLE
- CATCHBASIN
- GATE VALVE
- FIRE HYDRANT
- SANITARY SEWER
- STORM SEWER
- WATER MAIN
- INLET/OUTLET HEADWALL
- END CAP
- WHEEL CHAIR RAMP
- DRIVEWAY LETDOWN
- SIGN BASE

**NOTES:**

- 1) CONTRACTOR TO VERIFY LOCATION OF ALL EXISTING UTILITIES WITH ALL UTILITY COMPANIES PRIOR TO DIGGING.
- 2) CONTRACTOR TO CO-ORDINATE UTILITY RELOCATION WORKS WITH UTILITY COMPANIES AS REQUIRED.
- 3) ALL CONSTRUCTION TO BE IN ACCORDANCE WITH DISTRICT OF SALMON ARM SERVICE REQUIREMENTS.

**STORM DRAINAGE PLAN**

LEGEND

- EXISTING STORM MANHOLE
- EXISTING STORM MAIN
- PROPOSED STORM MANHOLE
- PROPOSED STORM MAIN
- MINOR STORM FLOW
- MAJOR STORM FLOW
- EXISTING AREA IN HECTARES EXISTING RUNOFF COEFFICIENT
- AREA IN HECTARES RUNOFF COEFFICIENT
- EXISTING DRAINAGE BOUNDARY
- PROPOSED DRAINAGE BOUNDARY
- EXISTING CONTOUR
- PROPOSED GRADE

**SANITARY DRAINAGE PLAN**

LEGEND

- EXISTING SANITARY MANHOLE
- EXISTING SANITARY MAIN
- PROPOSED SANITARY MANHOLE
- PROPOSED SANITARY MAIN
- PROPOSED DRAINAGE BOUNDARY
- EXISTING DRAINAGE BOUNDARY
- AREA IN HECTARES # OF UNITS PEOPLE PER UNIT
- AREA IN HECTARES EQUIVALENT POPULATION
- Ex. AREA IN HECTARES # OF UNITS PEOPLE PER UNIT
- Ex. AREA IN HECTARES EQUIVALENT POPULATION

<b>CITY OF SALMON ARM</b>		
No.	REVISION	Date
A	SDSB 4293 – ISSUED FOR APPROVAL	06/12/23

APPROVED

ANSI  
'D' SIZE LEGEND

---

SPECIFICATION  
DRAWING No.:

DD-LG







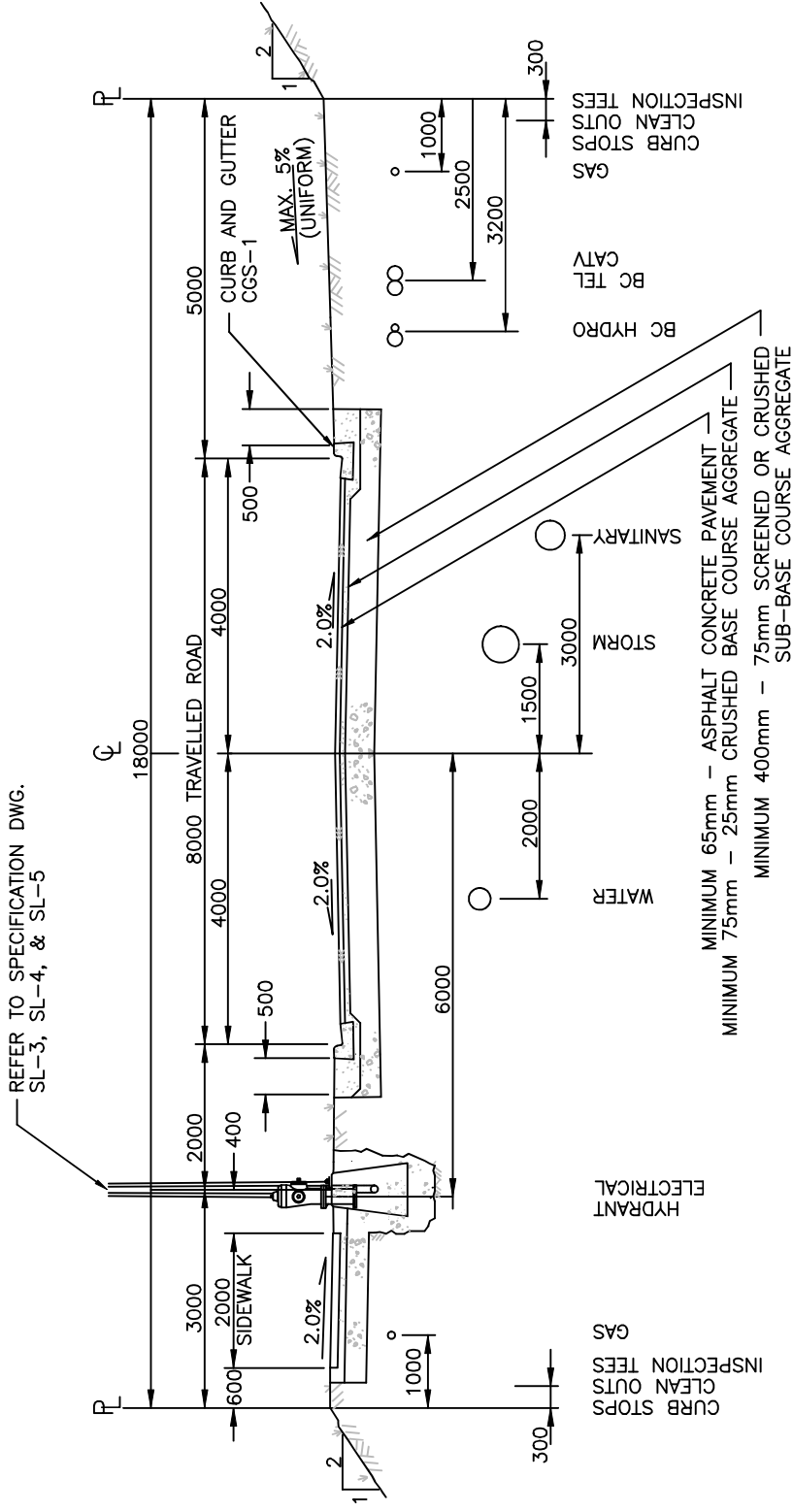

**NOTES:**

- 1) All utility appurtenances to be set to designed boulevard grade.
- 2) Boulevards to be graded towards the Roadway (Maximum 5% and Minimum 2%)
- 3) All materials shall be supplied and placed in accordance with schedule B, Part 3.0 and Schedule D, Approved material list.
- 4) Grades in excess of 2H:1V shall be recommended by a geotechnical engineer and approved by the City Engineer.

APPROVED

18m R/W Urban Local Road  
Cross-Section

SPECIFICATION  
DRAWING No.: RD-01

No.	REVISION	Date
A	SDSB 4293 – ISSUED FOR APPROVAL	06/12/23

**CITY OF SALMON ARM**

Permit to Practice: 1001265

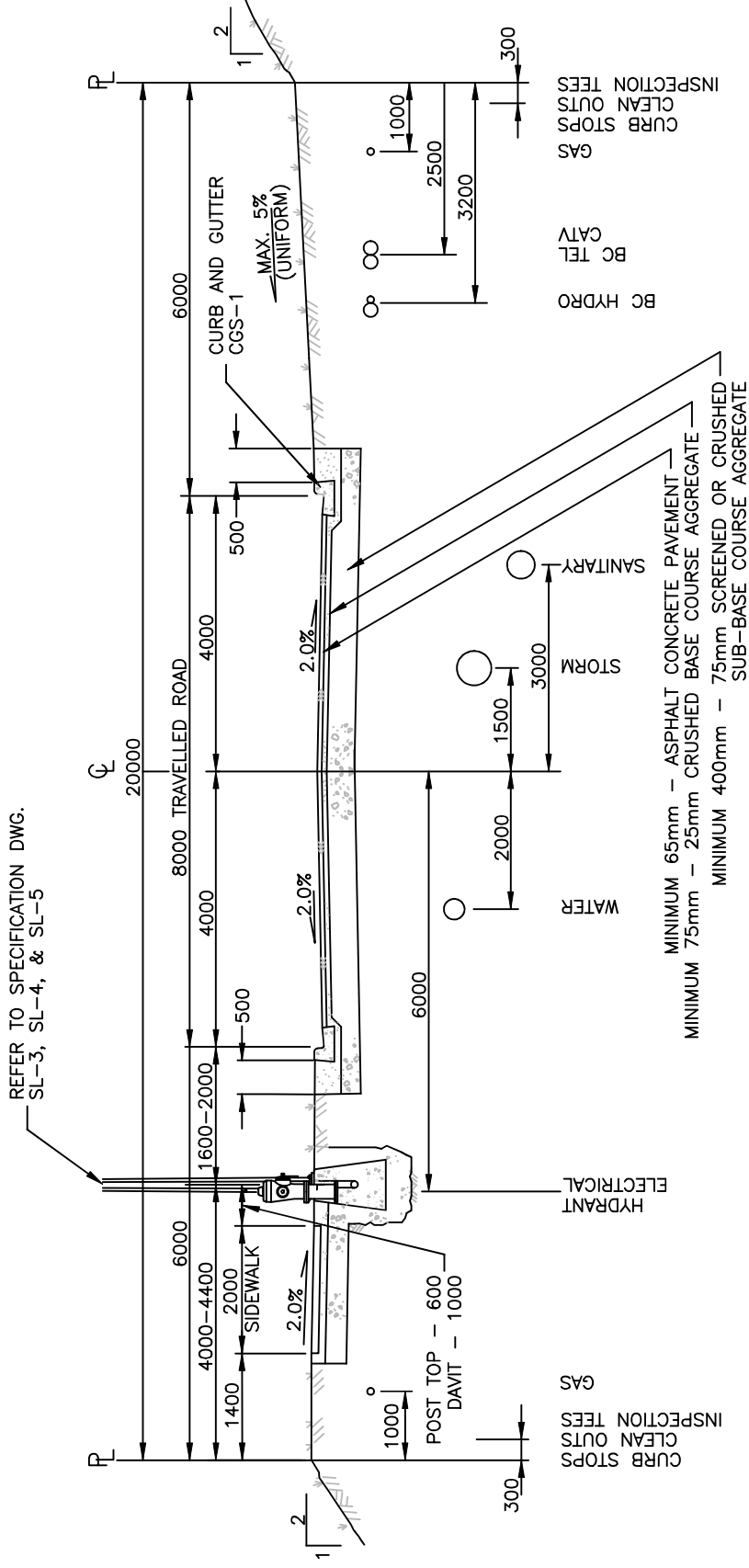

**NOTES:**

- 1) All utility appurtenances to be set to designed boulevard grade.
- 2) Boulevards to be graded towards the Roadway (Maximum 5% and Minimum 2%)
- 3) All materials shall be supplied and placed in accordance with schedule B, Part 3.0 and Schedule D, Approved material list.
- 4) Grades in excess of 2H:1V shall be recommended by a geotechnical engineer and approved by the City Engineer.

APPROVED



20m R/W Urban Local Road  
Cross-Section

No.	REVISION	Date
A	SDSB 4293 - ISSUED FOR APPROVAL	06/12/23

SPECIFICATION  
DRAWING No.: RD-02

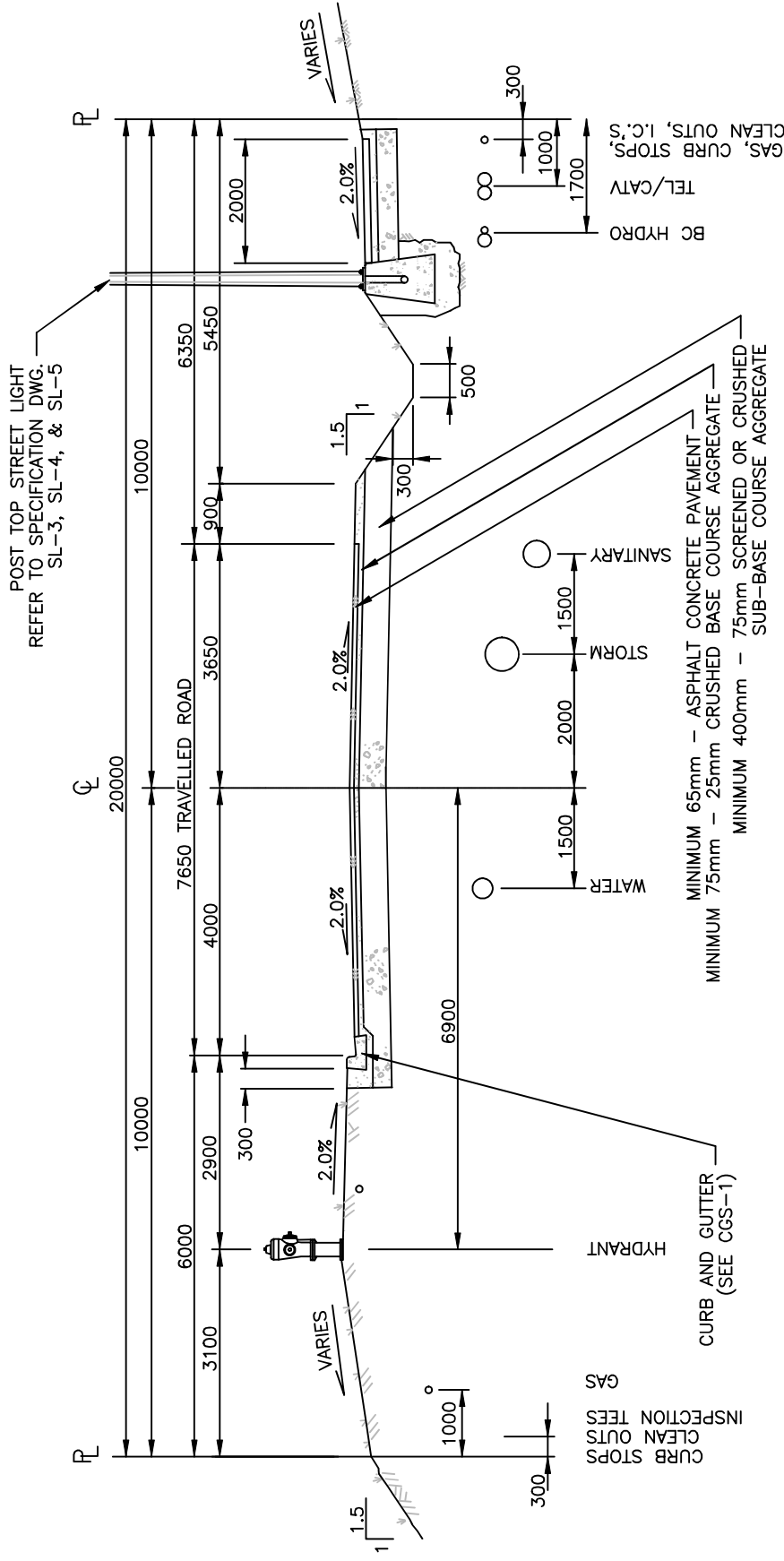

**NOTES:**

- 1) All utility appurtenances to be set to designed boulevard grade.
- 2) Boulevards to be graded towards the Roadway (Maximum 5% and Minimum 2%)
- 3) All materials shall be supplied and placed in accordance with schedule B, Part 3.0 and Schedule D, Approved material list.
- 4) Grades in excess of 1.5H:1V shall be recommended by a geotechnical engineer and approved by the City Engineer.

APPROVED



TYPICAL 20TH STREET NE  
ROAD SECTION

No.	REVISION	Date
A	SDSB 4293 – ISSUED FOR APPROVAL	06/12/23

SPECIFICATION  
DRAWING No.: RD-02 (MOD)

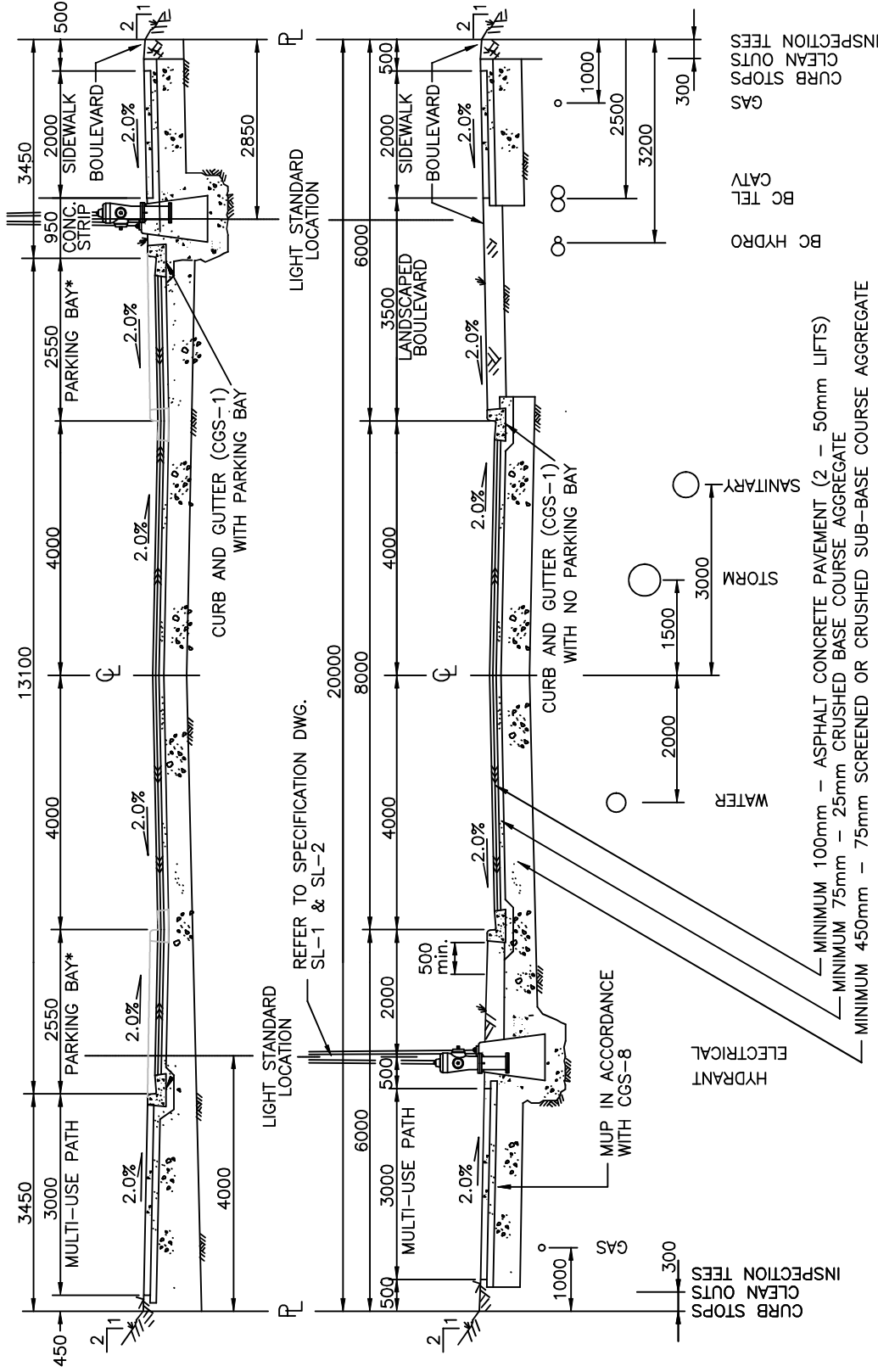

**NOTES:**

- 1) All utility appurtenances to be set to designed boulevard grade.
- 2) Boulevards to be graded towards the Roadway (Maximum 5% and Minimum 2%)
- 3) All materials shall be supplied and placed in accordance with schedule B, Part 3.0 and Schedule D, Approved material list.
- 4) Grades in excess of 2H:1V shall be recommended by a geotechnical engineer and approved by the City Engineer.

\* Parking bay shall be located on either or both sides of the roadway per design criteria in Schedule B-1.0 section 4.8.14

MINIMUM 100mm – ASPHALT CONCRETE PAVEMENT (2 – 50mm LIFTS)  
 MINIMUM 75mm – 25mm CRUSHED BASE COURSE AGGREGATE  
 MINIMUM 450mm – 75mm SCREENED OR CRUSHED SUB-BASE COURSE AGGREGATE

APPROVED

**20M R/W URBAN COLLECTOR  
 CROSS-SECTION**

<b>CITY OF SALMON ARM</b>	No.	REVISION	Date
	A	SDSB 4293 – ISSUED FOR APPROVAL	06/12/23

SPECIFICATION DRAWING No.: **RD-03**

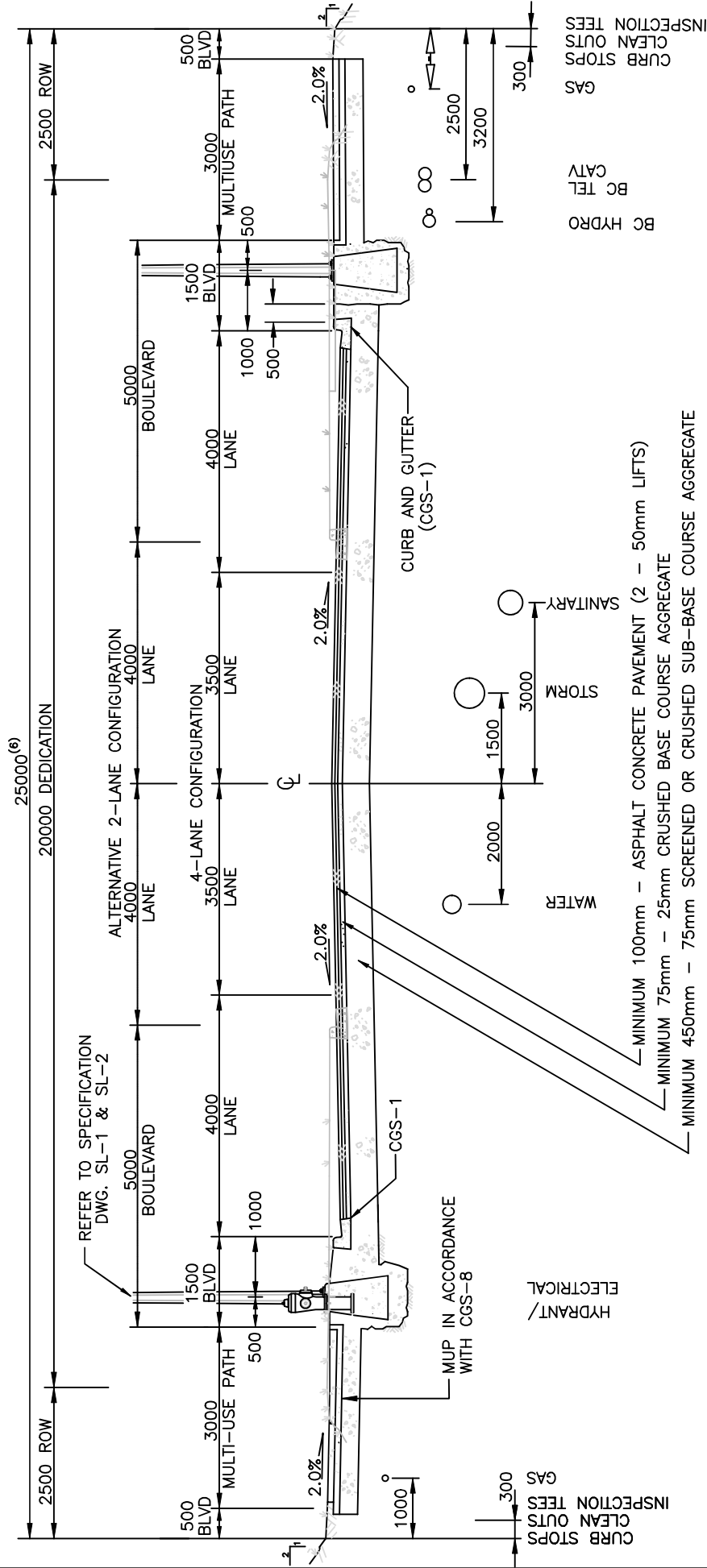

**NOTES:**

- 1) All utility appurtenances to be set to designed boulevard grade.
- 2) Boulevards to be graded towards the Roadway (Maximum 5% and Minimum 2%)
- 3) All materials shall be supplied and placed in accordance with schedule B, Part 3.0 and Schedule D, Approved material list.
- 4) Grades in excess of 2H:1V shall be recommended by a geotechnical engineer and approved by the City Engineer.
- 5) Additional 3.5m x 3.5m ROW may be required for BC Hydro infrastructure.
- 6) Where 25.0m of dedication is not available, ROW shall be provided to supplement available dedication.

Grades in excess of 2H:1V shall be recommended by a geotechnical engineer and approved by the City Engineer.



APPROVED

**25M R/W URBAN ARTERIAL ROAD CROSS-SECTION**

No.	REVISION	Date
A	SDSB 4293 – ISSUED FOR APPROVAL	06/12/23

**CITY OF SALMON ARM**

SPECIFICATION DRAWING No.: RD-04

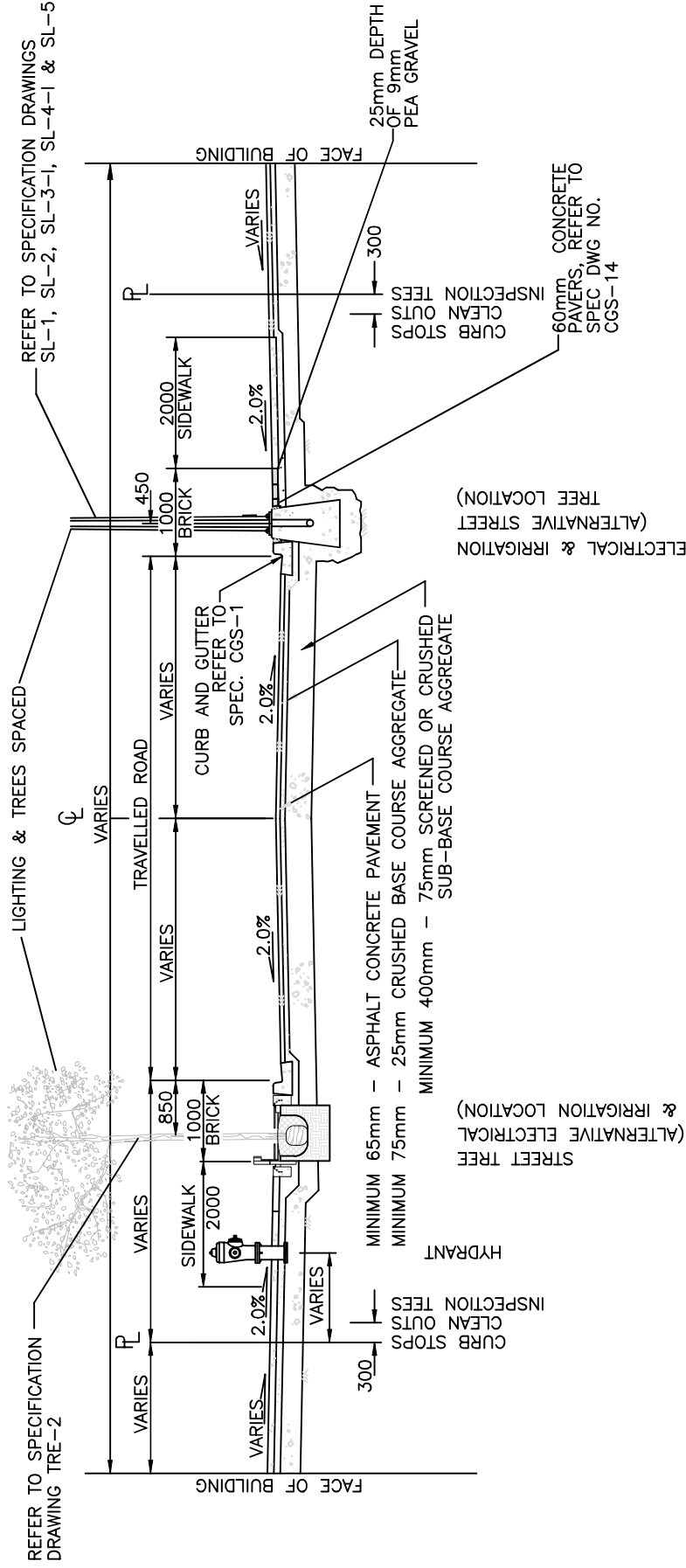

**NOTES:**

- 1) All utility appurtenances to be set to designed boulevard grade.
- 2) Boulevards to be graded towards the Roadway (Maximum 5% and Minimum 2%0
- 3) All materials shall be supplied and placed in accordance with schedule B, Part 3.0 and Schedule D, Approved material list.

APPROVED



TOWN CENTRE DEVELOPMENT  
AREA ROAD CROSS-SECTION

No.	REVISION	Date
A	SDSB 4293 - ISSUED FOR APPROVAL	06/12/23

**CITY OF SALMON ARM**

SPECIFICATION  
DRAWING No.:

RD-05

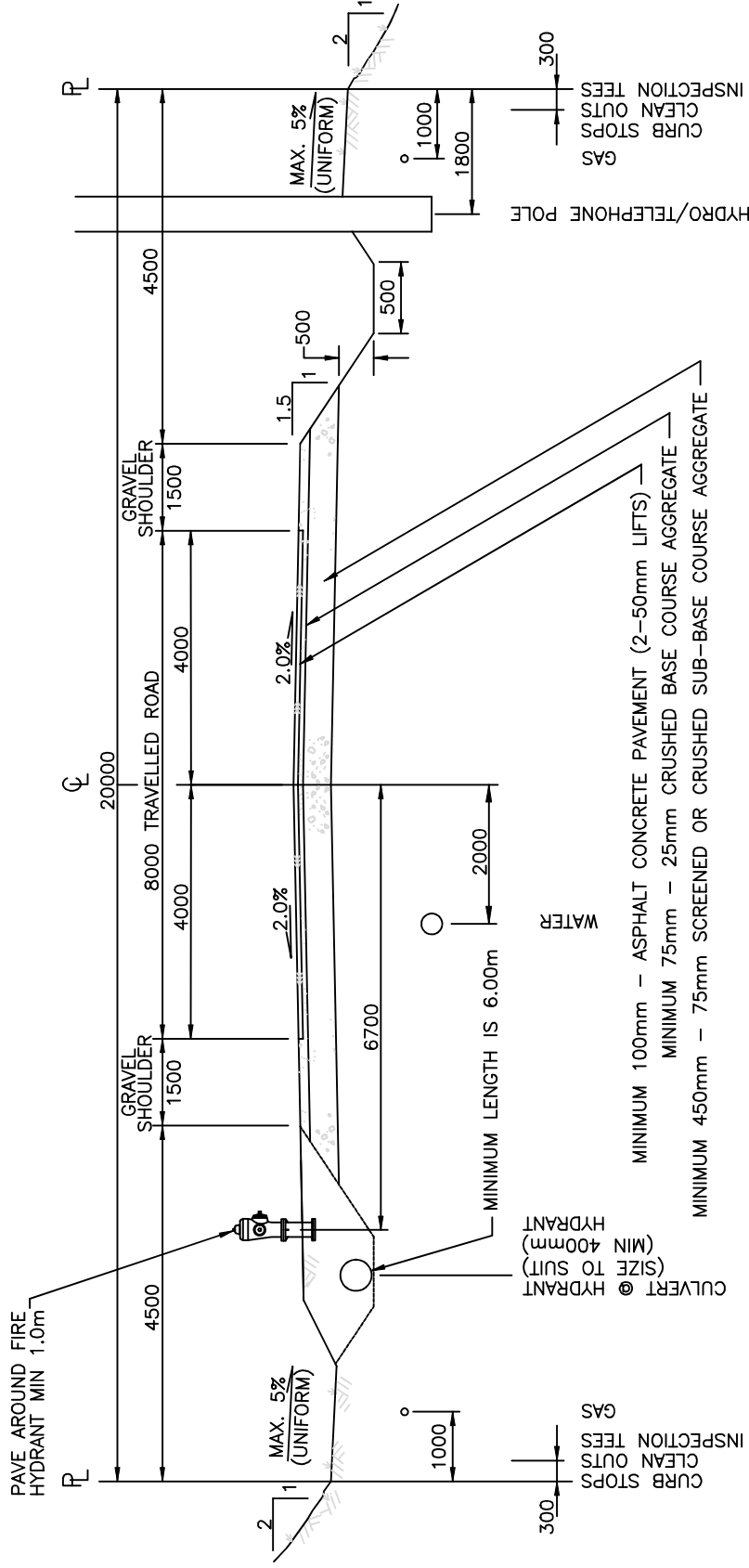

**NOTES:**

- 1) All utility appurtenances to be set to designed boulevard grade.
- 2) Boulevards to be graded towards the Roadway (Maximum 5% and Minimum 2%)
- 3) All materials shall be supplied and placed in accordance with schedule B, Part 3.0 and Schedule D, Approved material list.
- 4) Grades in excess of 2H:1V shall be recommended by a geotechnical engineer and approved by the City Engineer.

APPROVED



INDUSTRIAL AREA ROAD  
CROSS-SECTION

No.	REVISION	Date
A	SDSB 4293 – ISSUED FOR APPROVAL	06/12/23

SPECIFICATION  
DRAWING No.: RD-06A

**CITY OF SALMONARM**

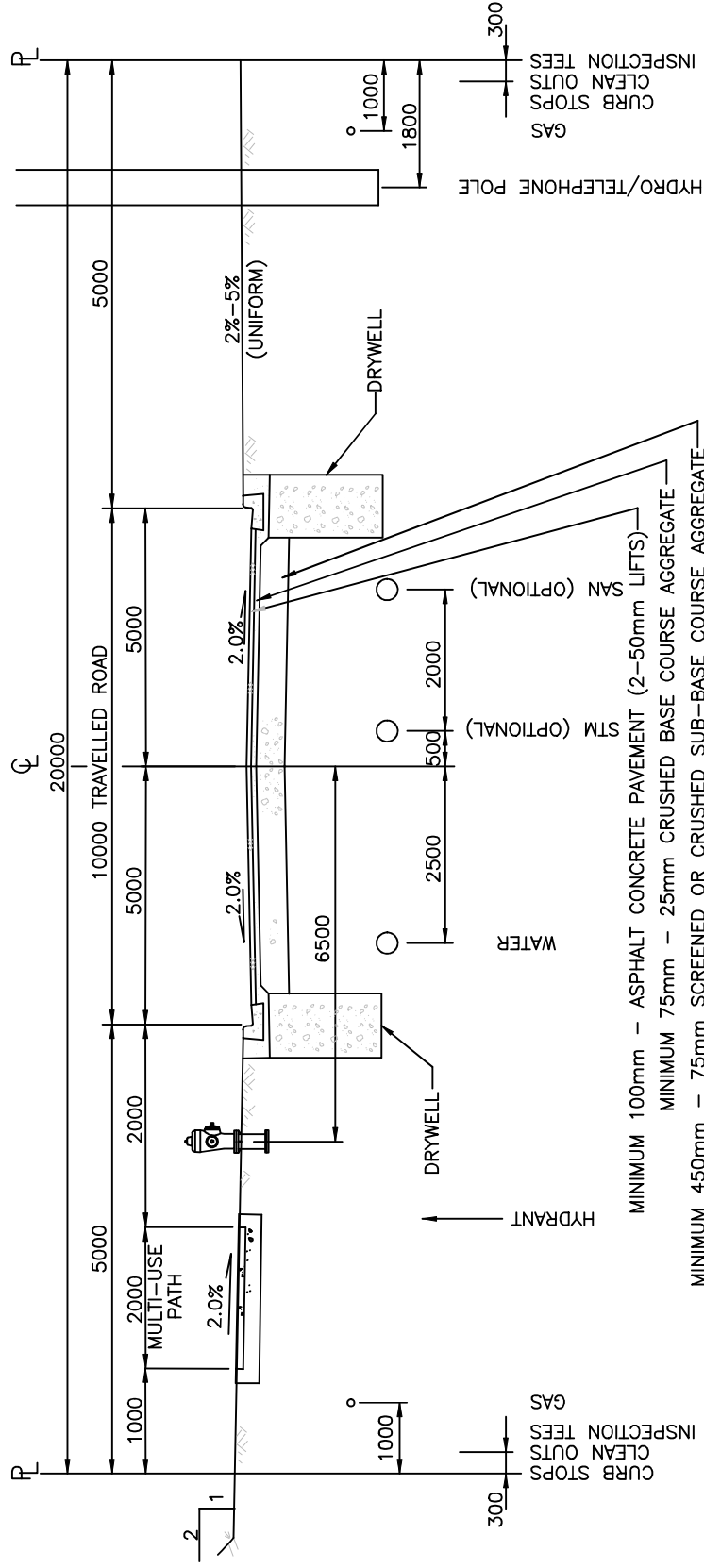

MINIMUM 100mm – ASPHALT CONCRETE PAVEMENT (2-50mm LIFTS)  
 MINIMUM 75mm – 25mm CRUSHED BASE COURSE AGGREGATE  
 MINIMUM 450mm – 75mm SCREENED OR CRUSHED SUB-BASE COURSE AGGREGATE

**NOTES:**

- 1) All utility appurtenances to be set to designed boulevard grade.
- 2) Boulevards to be graded towards the Roadway (Maximum 5% and Minimum 2%)
- 3) All materials shall be supplied and placed in accordance with schedule B, Part 3.0 and Schedule D, Approved material list.
- 4) Grades in excess of 2H:1V shall be recommended by a geotechnical engineer and approved by the City Engineer.

APPROVED

**NEW INDUSTRIAL PARK  
 CROSS-SECTION**

No.	REVISION	Date
A	SDSB 4293 – ISSUED FOR APPROVAL	06/12/23

SPECIFICATION  
 DRAWING No.: RD-06B

**CITY OF  
 SALMON ARM**



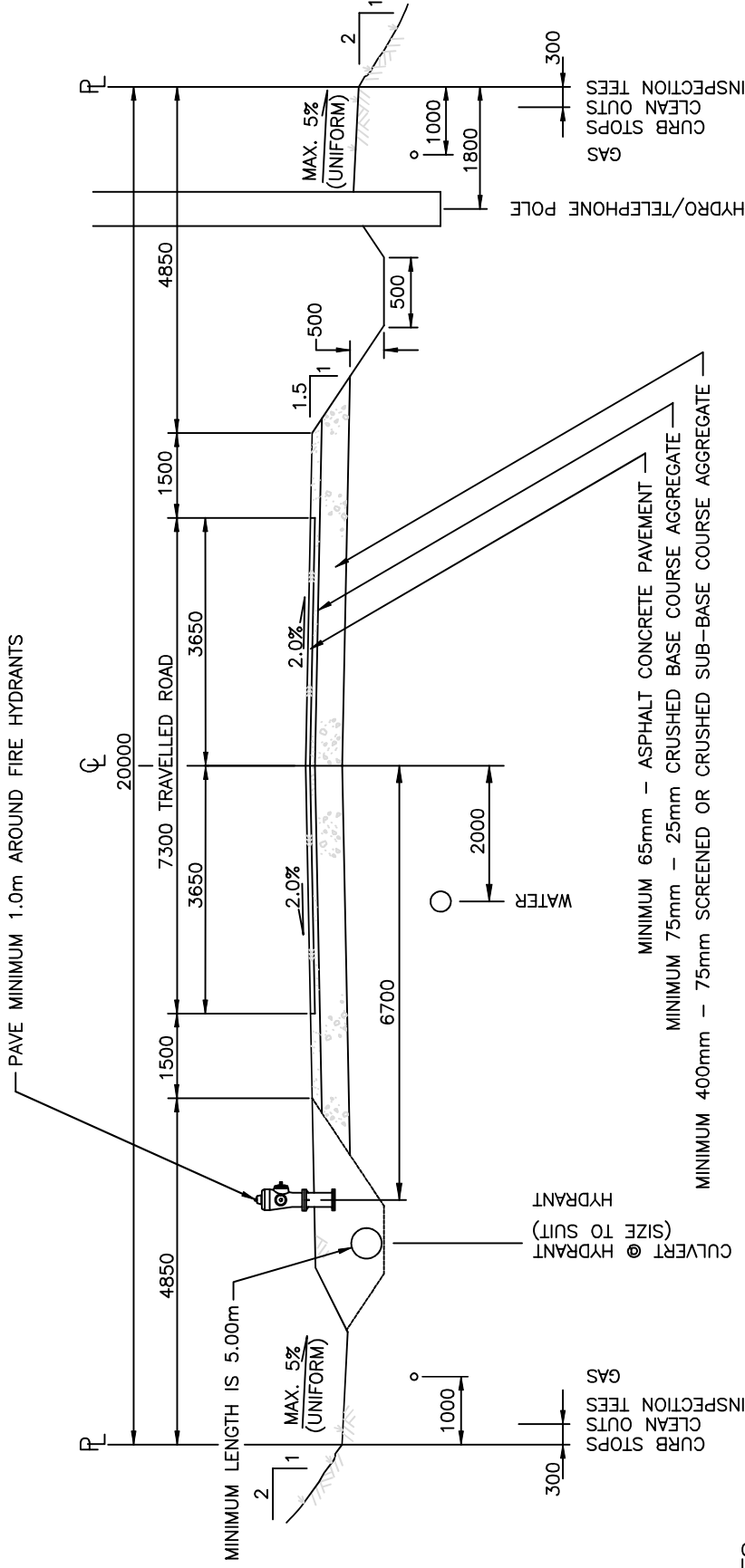

**NOTES:**

- 1) Where gravel surface is permitted, crossfall shall be 4.0%
- 2) Drainage shall be sheet drainage, no point load drainage permitted
- 3) All materials shall be supplied and placed in accordance with schedule B, Part 3.0 and Schedule D, Approved material list.
- 4) Grades in excess of 2H:1V shall be recommended by a geotechnical engineer and approved by the City Engineer.

APPROVED



20M R/W RURAL LOCAL ROAD  
CROSS-SECTION

No.	REVISION	Date
A	SDSB 4293 – ISSUED FOR APPROVAL	06/12/23

SPECIFICATION  
DRAWING No.: RD-07

**CITY OF SALMON ARM**

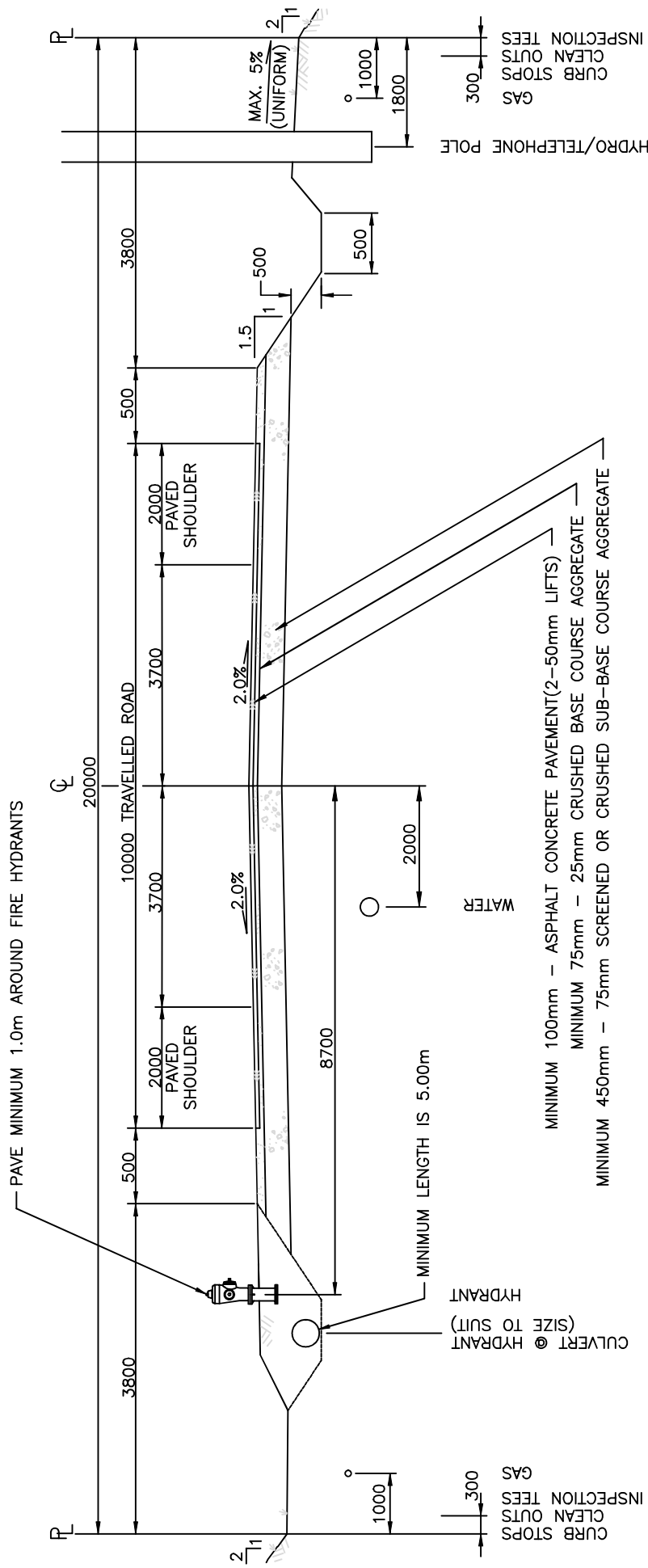

**NOTES:**

- 1) Where gravel surface is permitted, crossfall shall be 4.0%
- 2) Drainage shall be sheet drainage, no point load drainage permitted
- 3) All materials shall be supplied and placed in accordance with schedule B, Part 3.0 and Schedule D, Approved material list.
- 4) Grades in excess of 2H:1V shall be recommended by a geotechnical engineer and approved by the City Engineer.
- 5) Where ROW exists and topography allows, an offset 3.0m multi-use path shall be installed and the paved shoulders may be reduced to a 1.5m gravel shoulder.

APPROVED



20M R/W RURAL COLLECTOR  
ROAD CROSS-SECTION

No.	REVISION	Date
A	SDSB 4293 – ISSUED FOR APPROVAL	06/12/23

SPECIFICATION  
DRAWING No.: RD-08

**CITY OF SALMON ARM**

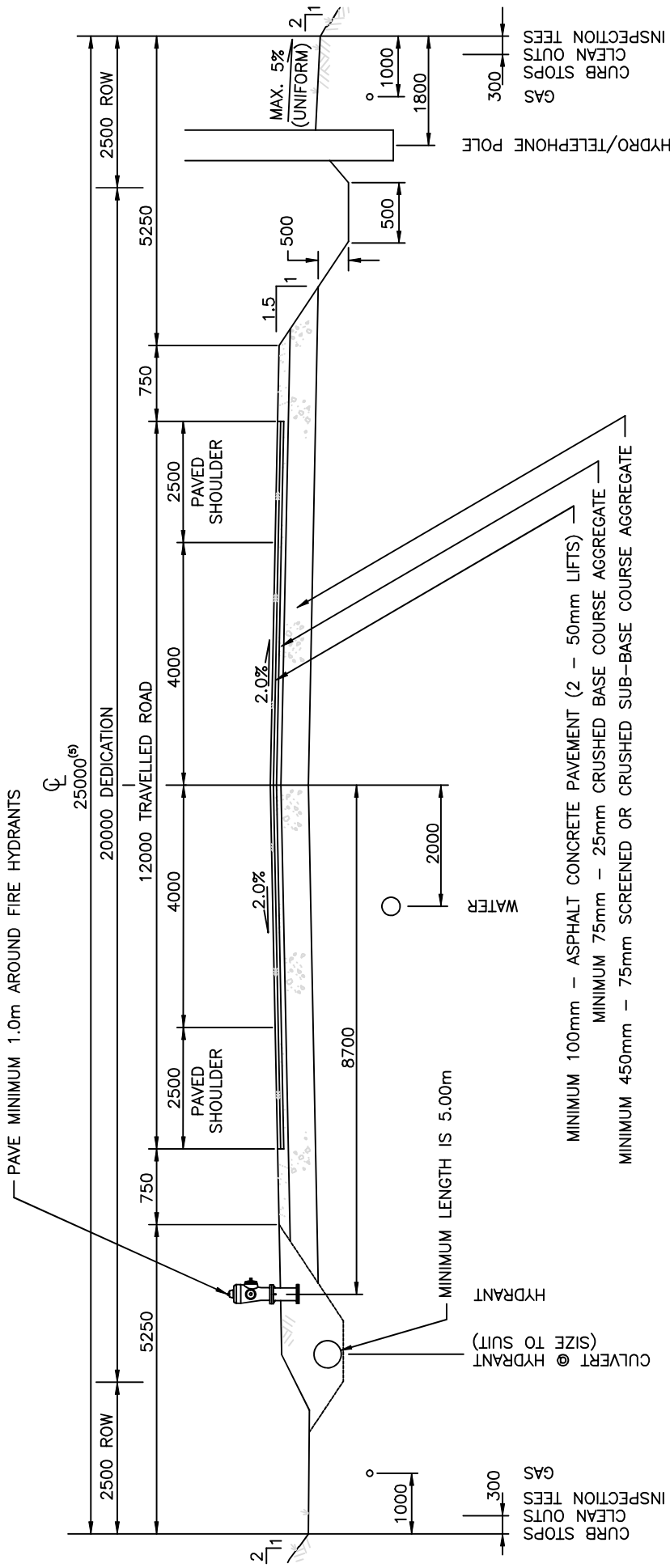

**NOTES:**

- 1) Where gravel surface is permitted, crossfall shall be 4.0%
- 2) Drainage shall be sheet drainage, no point load drainage permitted
- 3) All materials shall be supplied and placed in accordance with schedule B, Part 3.0 and Schedule D, Approved material list.
- 4) Grades in excess of 2H:1V shall be recommended by a geotechnical engineer and approved by the City Engineer.
- 5) Where 25.0m of dedication is not available, ROW shall be provided to supplement available dedication.
- 6) Where sufficient ROW exists and topography allows, an offset 3.0m Multi-use path shall be installed and the paved shoulders may be reduced to 1.5m gravel shoulder.

APPROVED

25M R/W RURAL ARTERIAL ROAD CROSS-SECTION

SPECIFICATION DRAWING No.: RD-09

No.	REVISION	Date
A	SDSB 4293 – ISSUED FOR APPROVAL	06/12/23

**CITY OF SALMON ARM**

Permit to Practice: 1001265

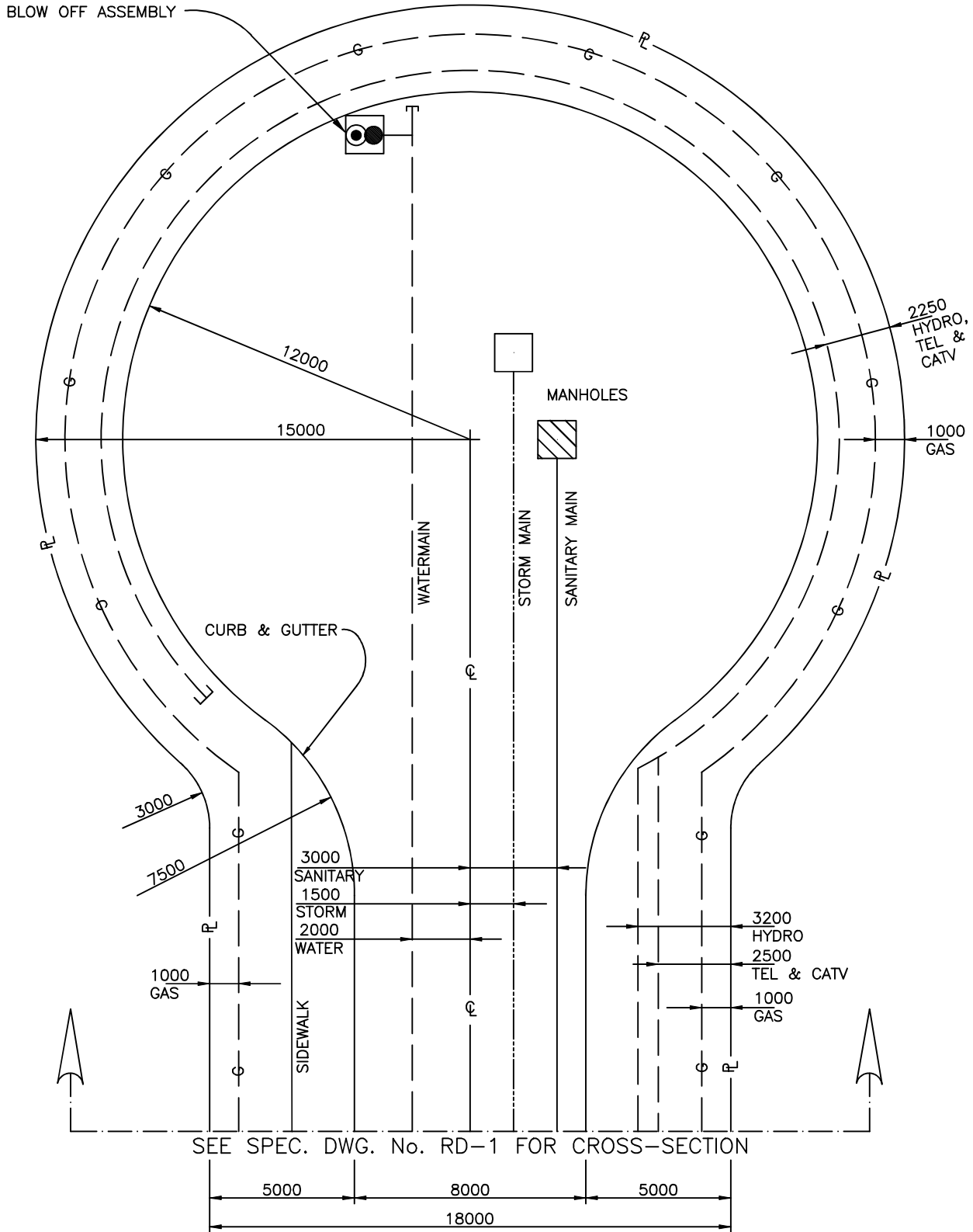

**NOTE:**

- 1) Fire Hydrant not to be located within Cul-de sac Right-of Way.
- 2) Refer to W-4 for Typical Blow off Assembly.
- 3) For Rural roads, cul-de-sac to have 10.75m radius for asphalt surface and edge of gravel shoulder to have 12.00m radius.

<b>CITY OF SALMON ARM</b>		
No.	REVISION	Date
A	SDSB 4293 – ISSUED FOR APPROVAL	06/12/23

APPROVED

18M R/W CUL-DE-SAC

SPECIFICATION DRAWING No.: RD-10

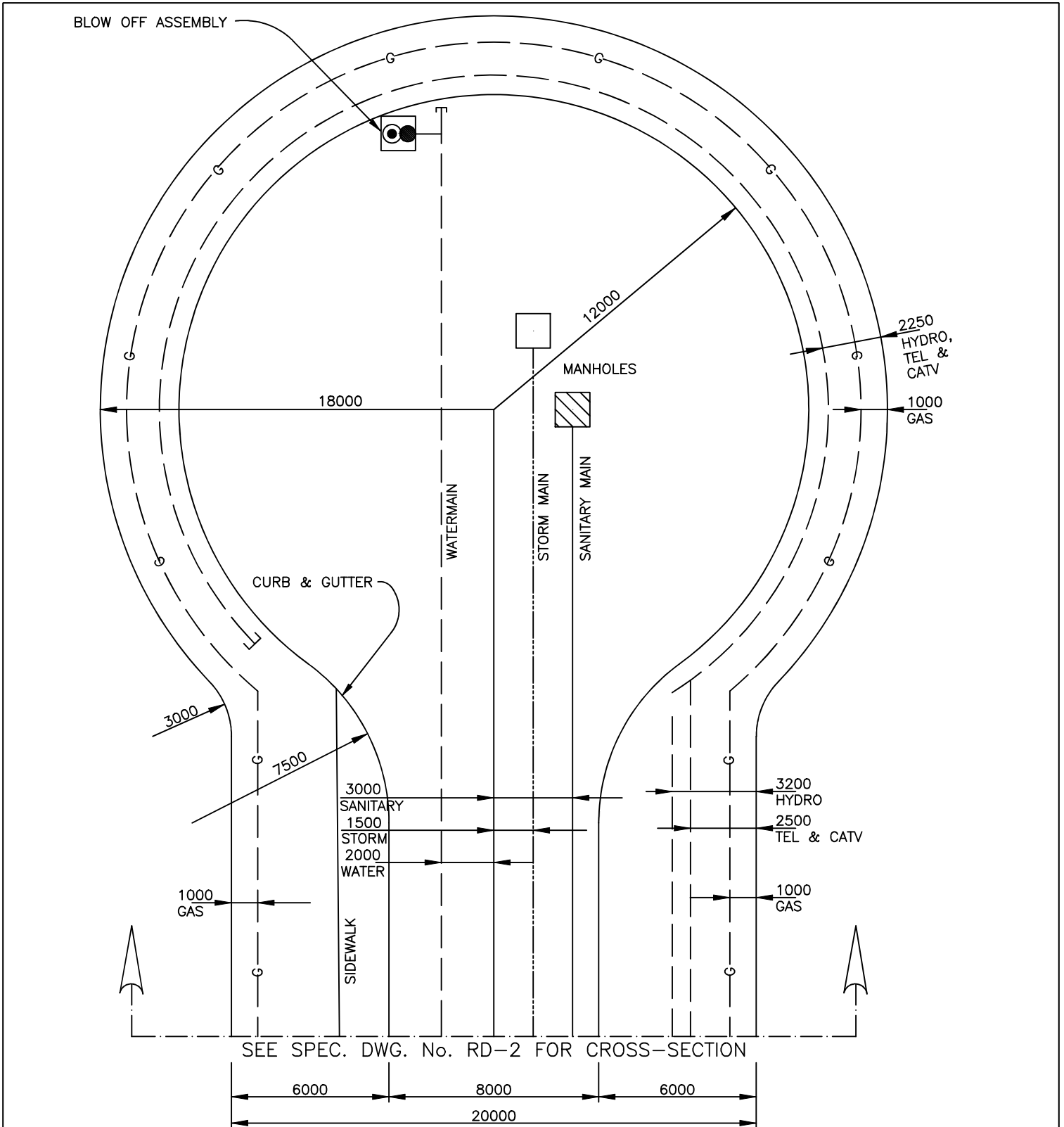

**NOTE:**

- 1) Fire Hydrant not to be located within Cul-de sac Right-of Way.
- 2) Refer to W-4 for Typical Blow off Assembly.
- 3) For Rural roads, cul-de-sac to have 10.75m radius for asphalt surface and edge of gravel shoulder to have 12.00m radius.

<b>CITY OF SALMON ARM</b>		
No.	REVISION	Date
A	SDSB 4293 – ISSUED FOR APPROVAL	06/12/23

APPROVED

20M R/W CUL-DE-SAC

SPECIFICATION DRAWING No.: RD-11

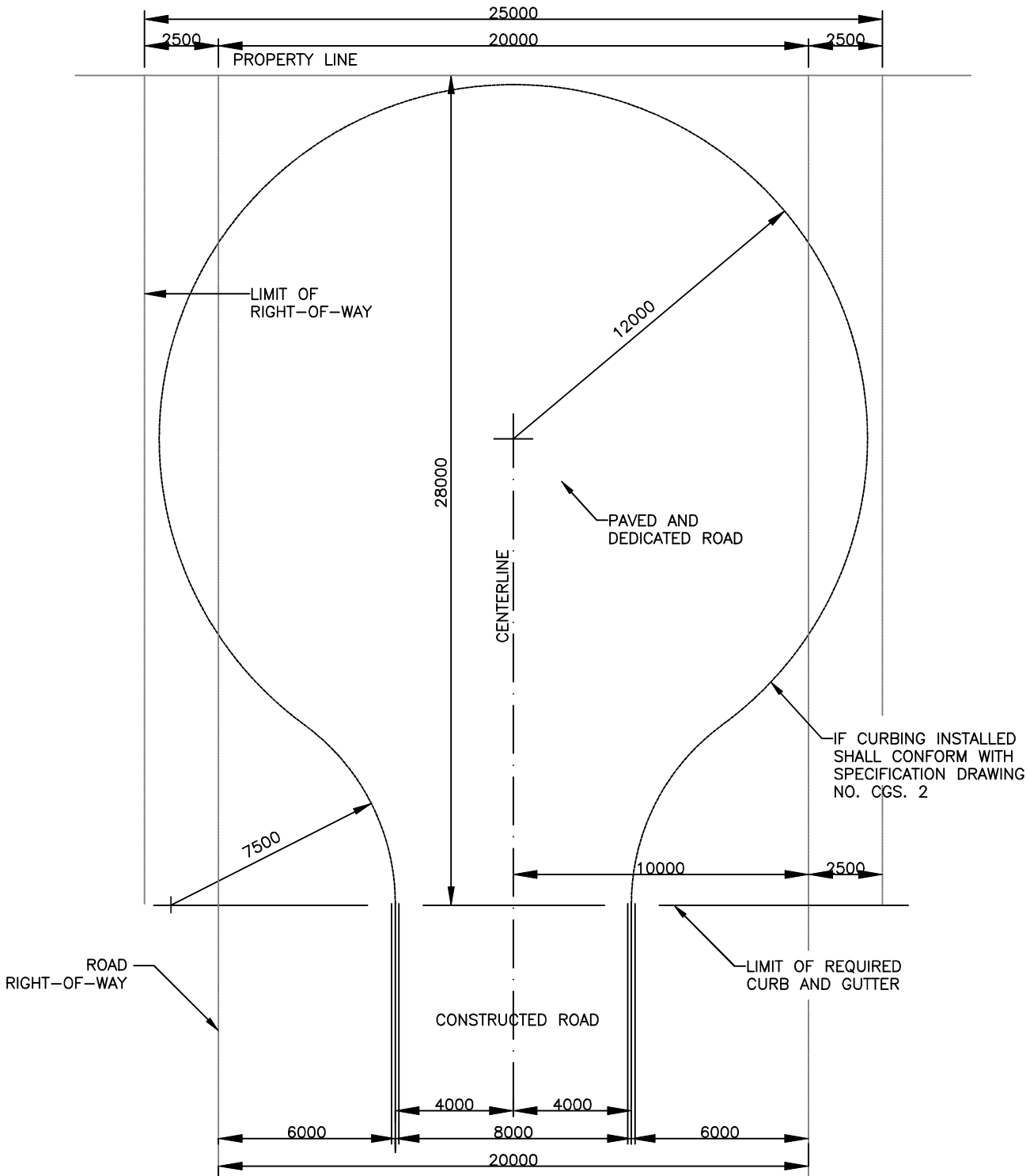

**NOTE:**

- 1) For rural roads, cul-de-sac to have 10.75m radius for asphalt surface and edge of gravel shoulder to have 12.0m radius.
- 2) Cash-in-lieu contribution will be required for portion of frontage works that fall within the cul-de-sac bulb.

<b>CITY OF SALMON ARM</b>		
No.	REVISION	Date
A	SDSB 4293 – ISSUED FOR APPROVAL	06/12/23

APPROVED



TEMPORARY CUL-DE-SAC

SPECIFICATION DRAWING No.:

RD-11A

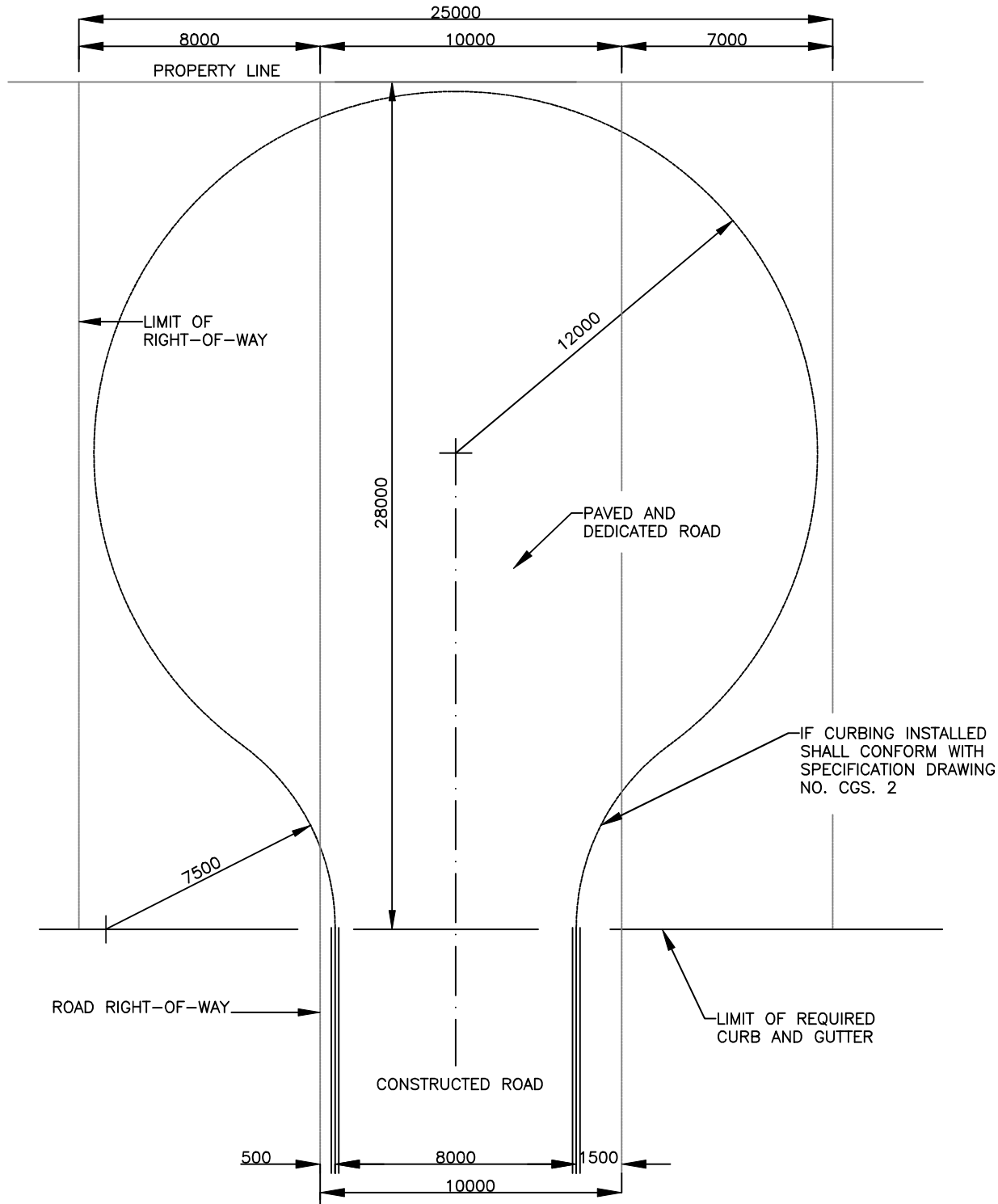

**NOTE:**

- 1) For rural roads, cul-de-sac to have 10.75m radius for asphalt surface and edge of gravel shoulder to have 12.0m radius.
- 2) Cash-in-lieu contribution required for portion of frontage works that fall within the cul-de-sac bulb.

**CITY OF SALMON ARM**

No.	REVISION	Date
A	SDSB 4293 – ISSUED FOR APPROVAL	06/12/23

APPROVED



10.0m R/W LANE-TEMPORARY CUL-DE-SAC

SPECIFICATION DRAWING No.:

RD-11B

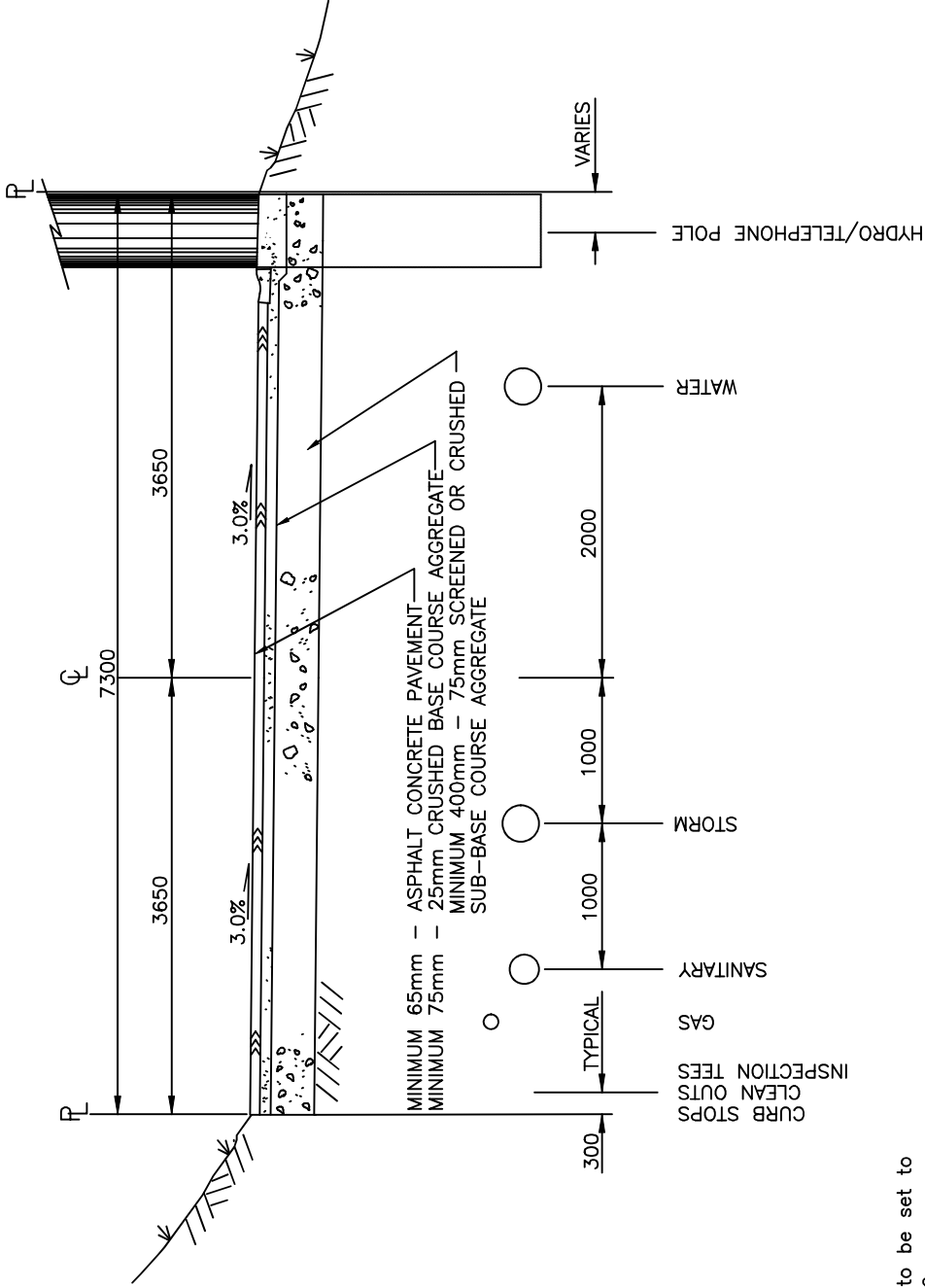

**NOTES:**

- 1) All utility appurtenances to be set to designed boulevard grade.
- 2) Boulevards to be graded towards the Roadway (Maximum 5% and Minimum 2%)
- 3) All materials shall be supplied and placed in accordance with schedule B, Part 3.0 and Schedule D, Approved material list.

APPROVED



7.3m R/W LANE  
CROSS-SECTION

No.	REVISION	Date
A	SDSB 4293 – ISSUED FOR APPROVAL	06/12/23

SPECIFICATION  
DRAWING No.: RD-12A

**CITY OF SALMON ARM**



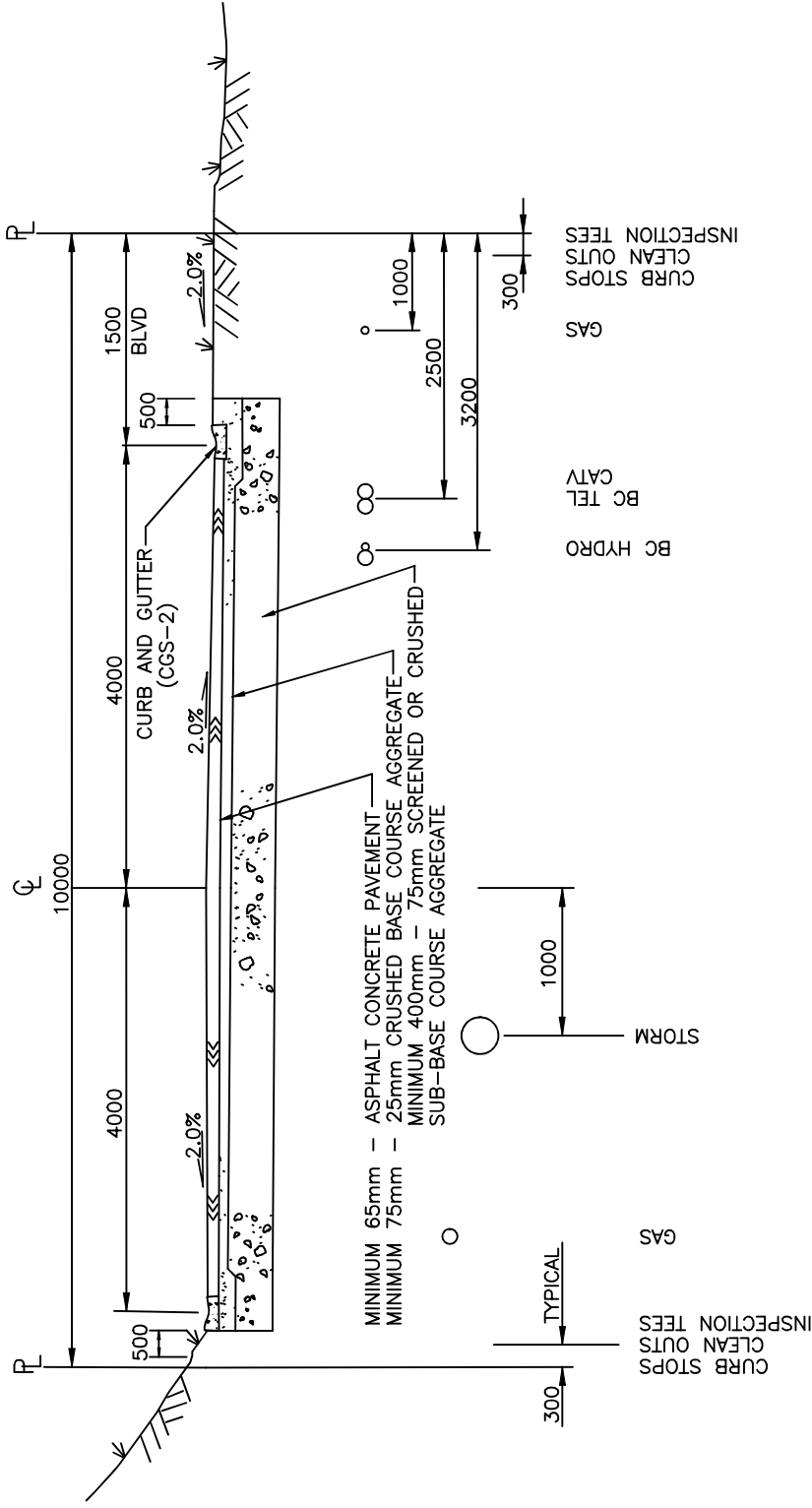

**NOTES:**

- 1) All utility appurtenances to be set to designed boulevard grade.
- 2) Boulevards to be graded towards the Roadway (Maximum 5% and Minimum 2%)
- 3) All materials shall be supplied and placed in accordance with schedule B, Part 3.0 and Schedule D, Approved material list.

APPROVED



10.0m R/W LANE  
CROSS-SECTION

No.	REVISION	Date
A	SDSB 4293 – ISSUED FOR APPROVAL	06/12/23

SPECIFICATION DRAWING No.:	RD-12B
-------------------------------	--------

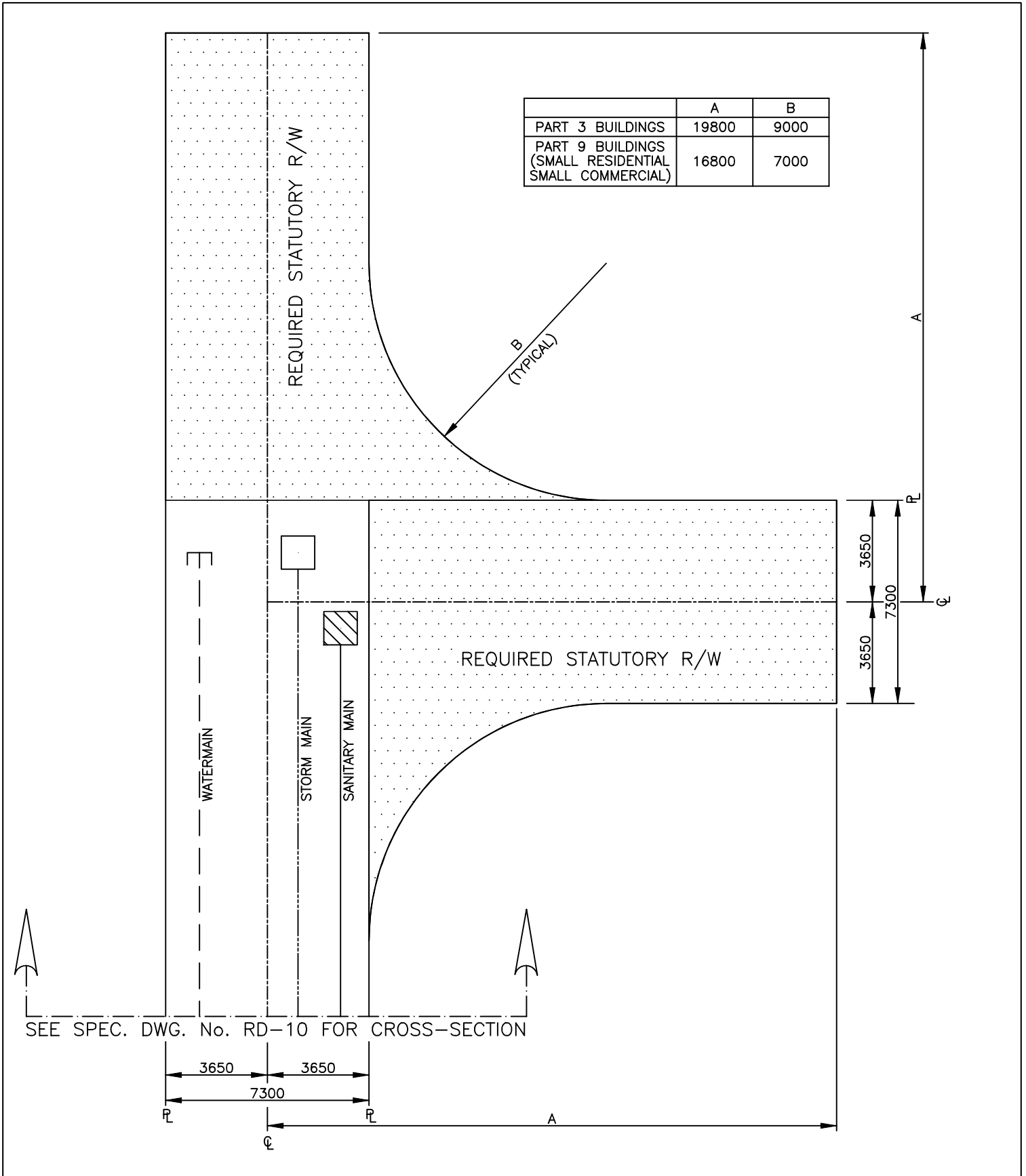

<b>CITY OF SALMON ARM</b>		
No.	REVISION	Date
A	SDSB 4293 – ISSUED FOR APPROVAL	06/12/23

APPROVED



LANE – 'T' TURN AROUND

SPECIFICATION  
DRAWING No.: RD-13

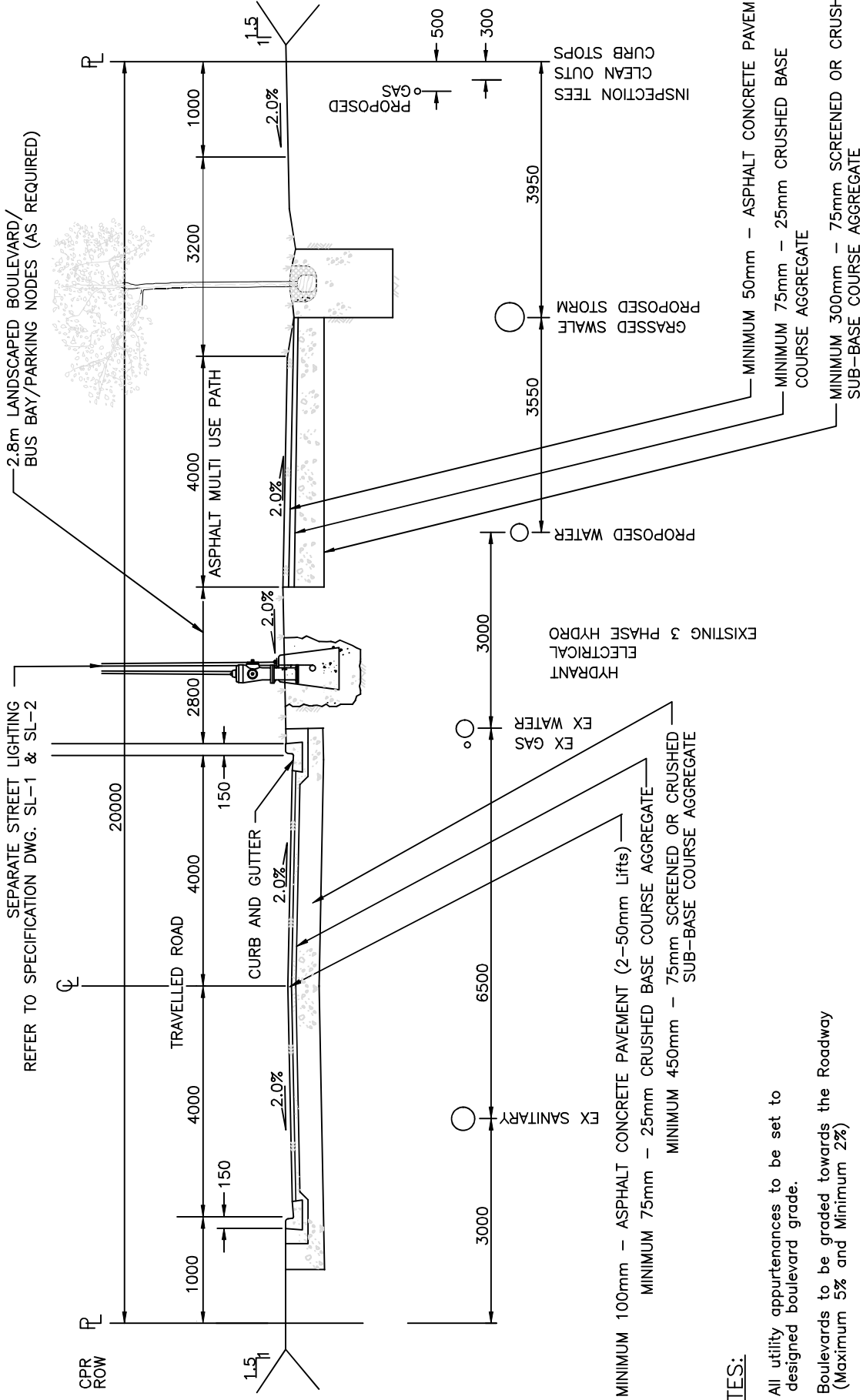

MINIMUM 100mm – ASPHALT CONCRETE PAVEMENT (2–50mm Lifts)  
 MINIMUM 75mm – 25mm CRUSHED BASE COURSE AGGREGATE  
 MINIMUM 450mm – 75mm SCREENED OR CRUSHED SUB-BASE COURSE AGGREGATE

MINIMUM 50mm – ASPHALT CONCRETE PAVEMENT  
 MINIMUM 75mm – 25mm CRUSHED BASE COURSE AGGREGATE  
 MINIMUM 300mm – 75mm SCREENED OR CRUSHED SUB-BASE COURSE AGGREGATE

**NOTES:**

- 1) All utility appurtenances to be set to designed boulevard grade.
- 2) Boulevards to be graded towards the Roadway (Maximum 5% and Minimum 2%)
- 3) All materials shall be supplied and placed in accordance with schedule B, Part 3.0 and Schedule D, Approved material list.

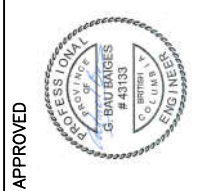

APPROVED

CANOE BEACH DRIVE 20M R/W  
 ROAD CROSS-SECTION (53RD ST.  
 NE TO PARK HILL)

No.	REVISION	Date
A	SDSB 4293 – ISSUED FOR APPROVAL	06/12/23

**CITY OF SALMON ARM**

SPECIFICATION  
 DRAWING No.:

RD-14

CURB AND GUTTER  
CGS-1  
REFER TO SPECIFICATION DWG.  
SL-3, SL-4, & SL-5

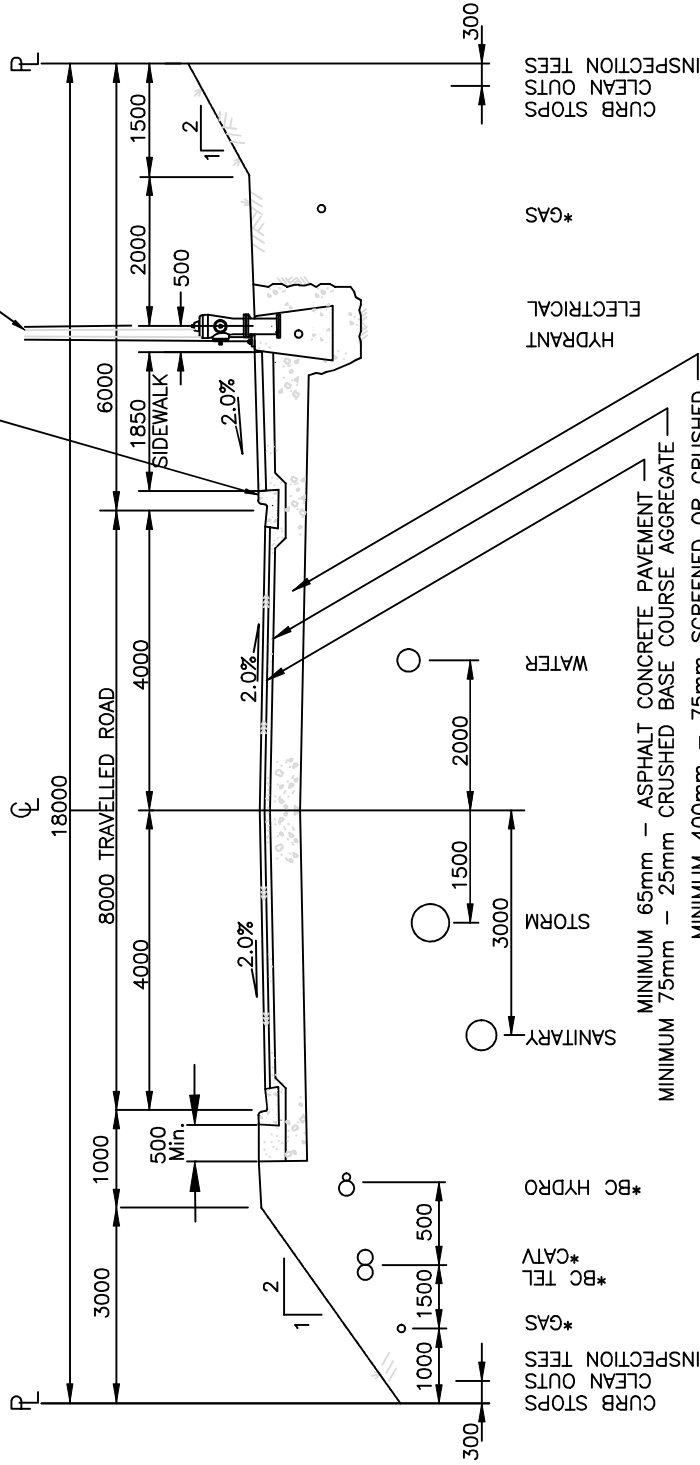

\*Locations of utilities may vary to accommodate topographic issues

**NOTES:**

- 1) All utility appurtenances to be set to designed boulevard grade.
- 2) Boulevards to be graded towards the Roadway (Maximum 5% and Minimum 2%)
- 3) All materials shall be supplied and placed in accordance with schedule B, Part 3.0 and Schedule D, Approved material list.
- 4) Disturbed slopes shall be hydroseeded.
- 5) Grades in excess of 2H:1V shall be recommended by a geotechnical engineer and approved by the City Engineer.
- 6) Driveways on low side of road shall have a minimum highpoint 0.10m above road gutterline, or as required by the hydraulic capacity of roadway.
- 7) Locations of transformers/pedestals/junction boxes/service tubs to be confirmed on site specific basis.



APPROVED

18M R/W URBAN LOCAL ROAD  
CROSS-SECTION (HILLSIDE  
DEVELOPMENT)

No.	REVISION	Date
A	SDSB 4293 – ISSUED FOR APPROVAL	06/12/23

**CITY OF SALMON ARM**

Permit to Practice: 1001265

SPECIFICATION  
DRAWING No.:

RD-15

Adopted by Council June 26, 2023

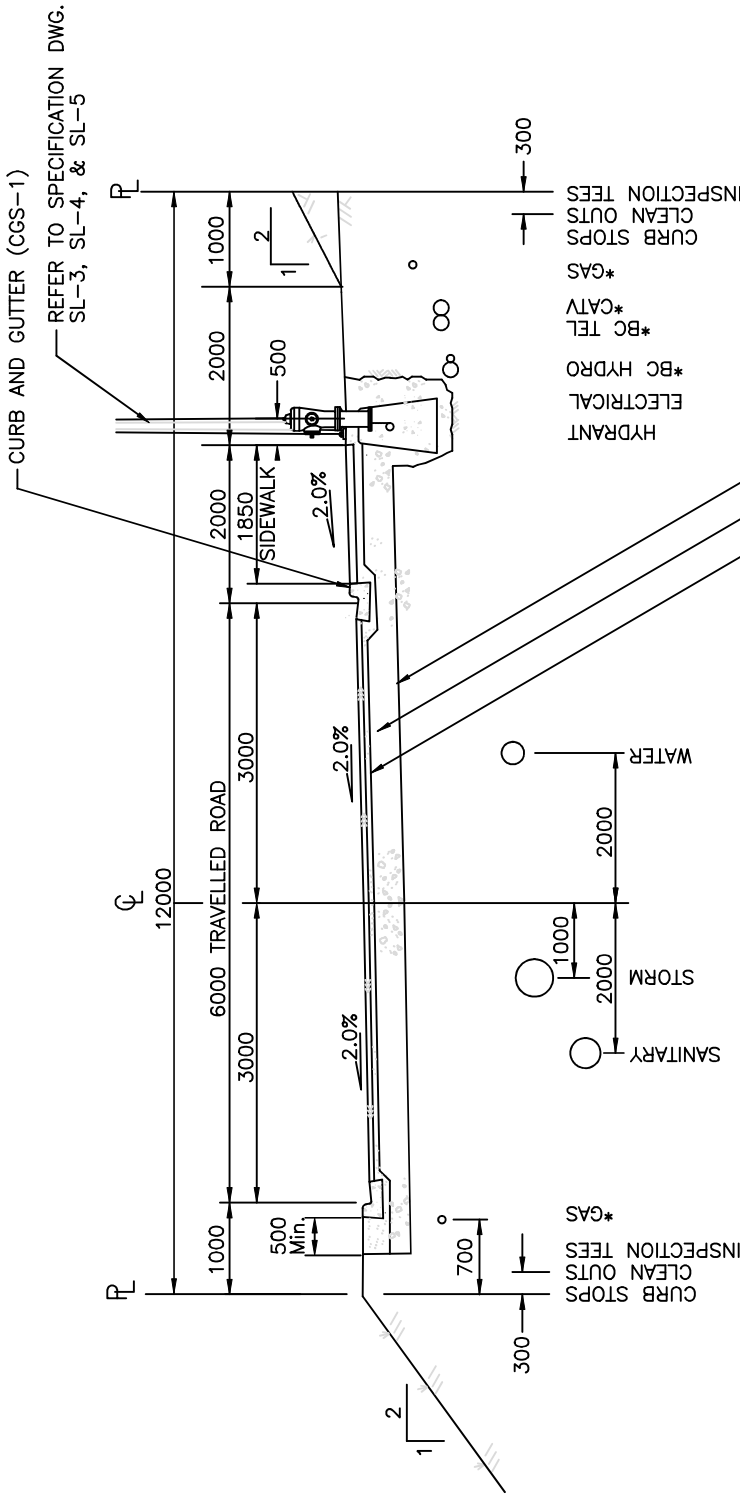

\*Locations of utilities may vary to accommodate topographic issues

MINIMUM 65mm – ASPHALT CONCRETE PAVEMENT  
 MINIMUM 75mm – 25mm CRUSHED BASE COURSE AGGREGATE  
 MINIMUM 400mm – 75mm SCREENED OR CRUSHED SUB-BASE COURSE AGGREGATE

**NOTES:**

- 1) All utility appurtenances to be set to designed boulevard grade.
- 2) Boulevards to be graded towards the Roadway (Maximum 5% and Minimum 2%)
- 3) All materials shall be supplied and placed in accordance with schedule B, Part 3.0 and Schedule D, Approved material list.
- 4) Disturbed slopes shall be hydroseeded.
- 5) Grades in excess of 2H:1V shall be recommended by a geotechnical engineer and approved by the City Engineer.
- 6) Driveways on low side of road shall have a minimum highpoint 0.10m above road gutterline, or as required by the hydraulic capacity of roadway.
- 7) Locations of transformers/pedestals/junction boxes/service tubs to be confirmed on site specific basis.



12M R/W URBAN SINGLE LANE  
 LOCAL ROAD CROSS-SECTION  
 (HILLSIDE DEVELOPMENT)

No.	REVISION	Date
A	SDSB 4293 – ISSUED FOR APPROVAL	06/12/23

SPECIFICATION  
 DRAWING No.: RD-16

**CITY OF SALMON ARM**

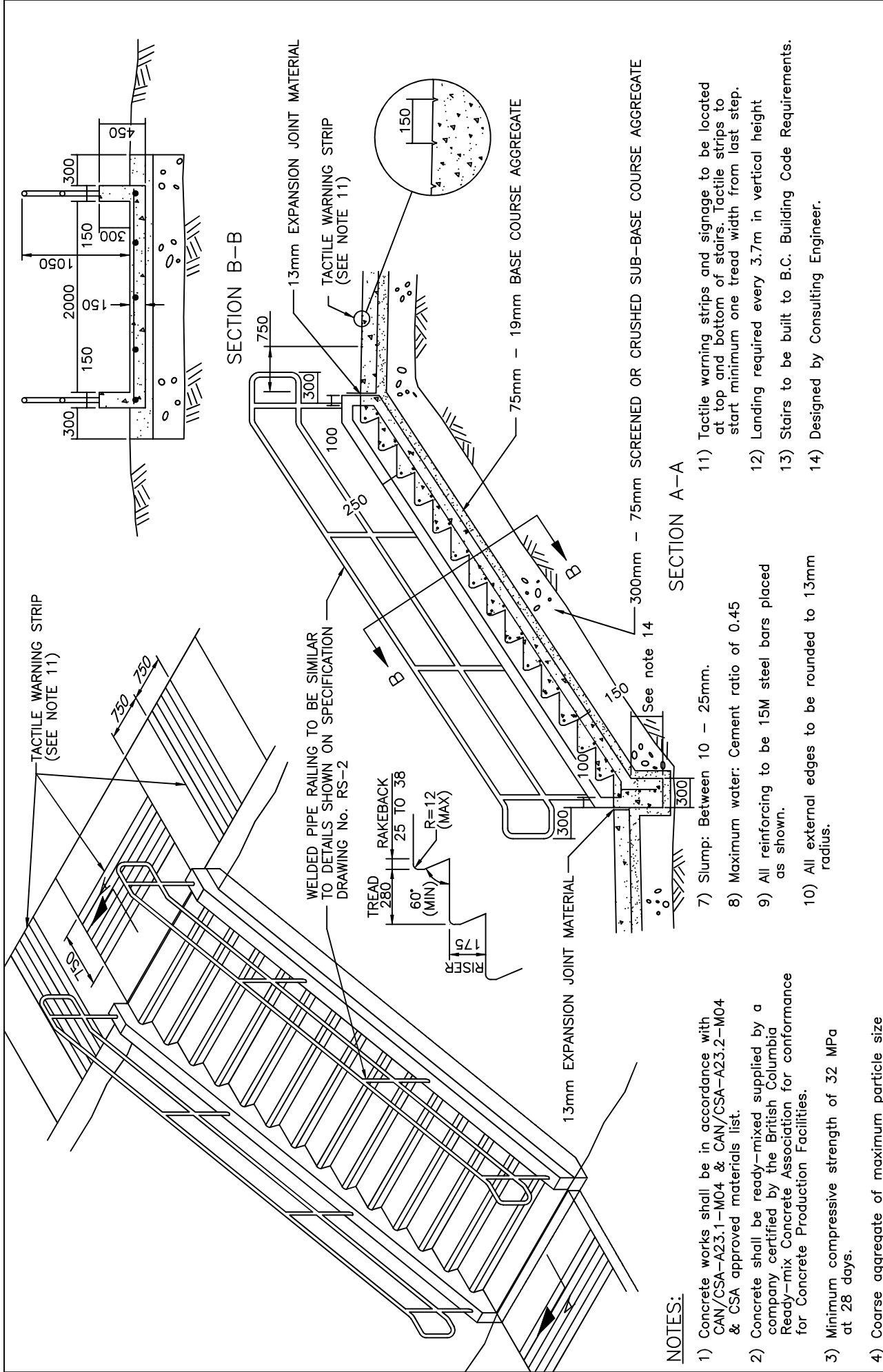

**NOTES:**

- 1) Concrete works shall be in accordance with CAN/CSA-A23.1-M04 & CAN/CSA-A23.2-M04 & CSA approved materials list.
- 2) Concrete shall be ready-mixed supplied by a company certified by the British Columbia Ready-mix Concrete Association for conformance for Concrete Production Facilities.
- 3) Minimum compressive strength of 32 MPa at 28 days.
- 4) Coarse aggregate of maximum particle size not exceeding 19mm.
- 5) Minimum cement content of 350 kg/m<sup>3</sup>.
- 6) Entrained air of 5–8%.
- 7) Slump: Between 10 – 25mm.
- 8) Maximum water: Cement ratio of 0.45
- 9) All reinforcing to be 15M steel bars placed as shown.
- 10) All external edges to be rounded to 13mm radius.
- 11) Tactile warning strips and signage to be located at top and bottom of stairs. Tactile strips to start minimum one tread width from last step.
- 12) Landing required every 3.7m in vertical height
- 13) Stairs to be built to B.C. Building Code Requirements.
- 14) Designed by Consulting Engineer.



APPROVED

**REINFORCED CONCRETE STAIRS**

SPECIFICATION  
DRAWING No.: **RS-1**

No.	REVISION	Date
A	SDSB 4293 – ISSUED FOR APPROVAL	06/12/23

**CITY OF**  
**SALMON ARM**

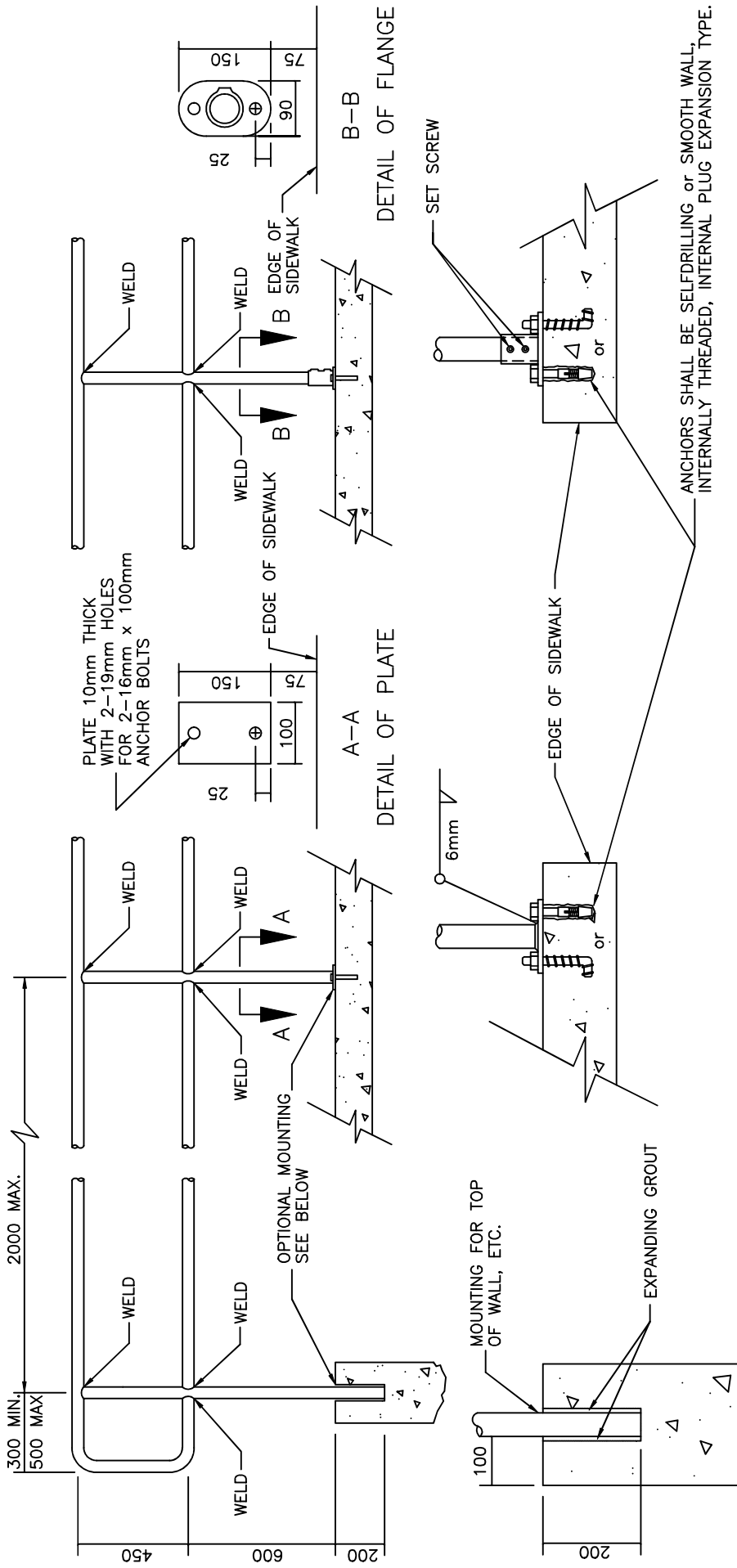

SLEEVE INSERT TYPE

ANCHOR PLATE TYPE

ANCHOR FLANGE TYPE

NOTES:

- 1) All posts and rails to be 48mm O.D. to A.S.T.M. A 120 'Standard' weight (Schedule 40).
- 2) Welds shall be full bead and shall have all rough edges ground smooth after fabrication.
- 3) Pipe fittings shall be malleable iron with case hardened set-screws conforming to A.S.T.M. A 47 grade 32510.
- 4) Final finish, upon completion of fabrication, to be factory powder coating as follows:
  - Min. 2.5-4 mil of epoxy thermosetting powder basecoat
  - Min 4-6 mil of polyester thermosetting powder topcoat
  - Color to be selected by owner

APPROVED



SIDEWALK RAILING

SPECIFICATION DRAWING No.: RS-02

No.	REVISION	Date
A	SDSB 4293 - ISSUED FOR APPROVAL	06/12/23

**CITY OF SALMON ARM**

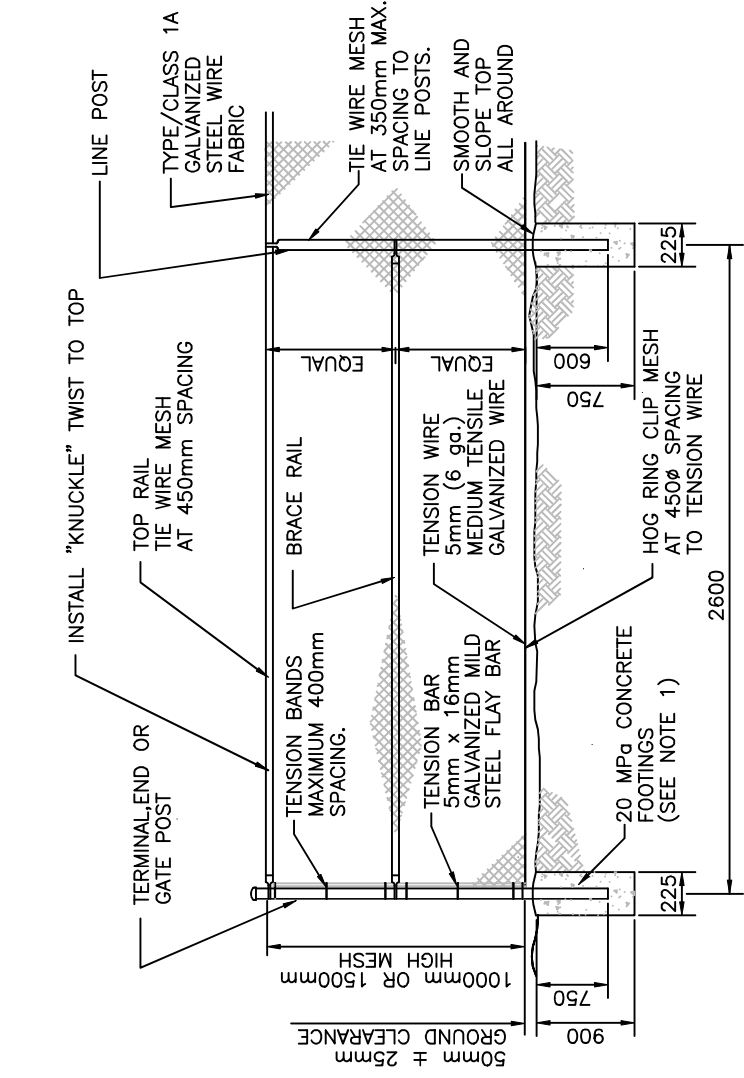

POST AND RAIL SIZES – O.D. MINIMUM

STANDARD	LINE POSTS
60	END, CORNER, & STRAINING POSTS
90 Sch.40	TOP RAILS
42	HORIZONTAL BRACE RAILS*
33	

\*NOTE: DIAGONAL PIPE BRACES MAY BE SPECIFIED WHERE SOIL CONDITIONS WARRANT, ESPECIALLY WHERE TOP TENSION WIRE IS CALLED FOR IN PLACE OF TOP RAIL.

NOTES:

- 1) All concrete footings to be 20 MPa at 28 days.
- 2) Final finish to be Double Hot Dipped Galvanizing, minimum 360 g/m<sup>2</sup>.
- 3) Tension bar should go through every mesh loop and fastened to terminal and straining posts with tension bands as specified above
- 4) Steel wire fabric shall be "knuckle" twist at top; Bottom may be standard twist.

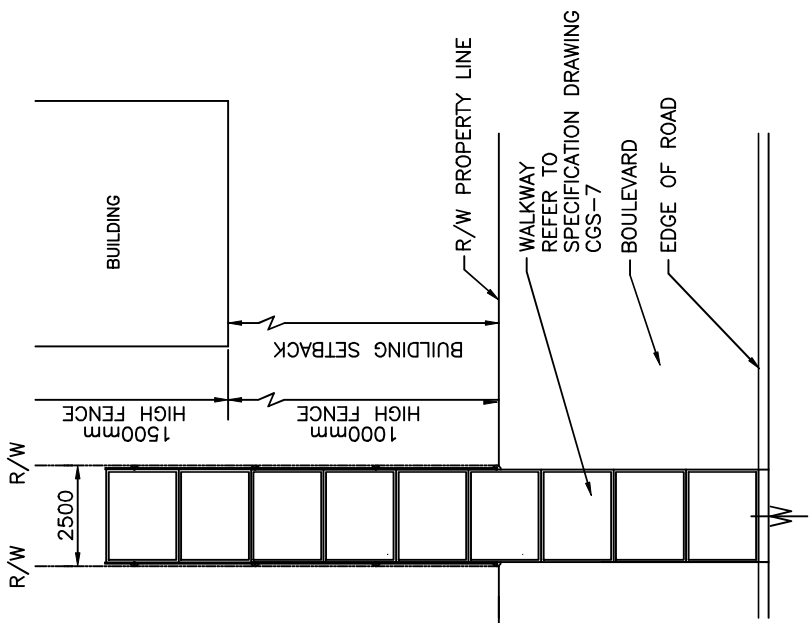

APPROVED



CHAIN LINK FENCE FOR WALKWAY

<b>CITY OF</b> <b>SALMON ARM</b>	No.	REVISION	Date
	A	SDSB 4293 – ISSUED FOR APPROVAL	06/12/23

RS-03

SPECIFICATION  
DRAWING No.:



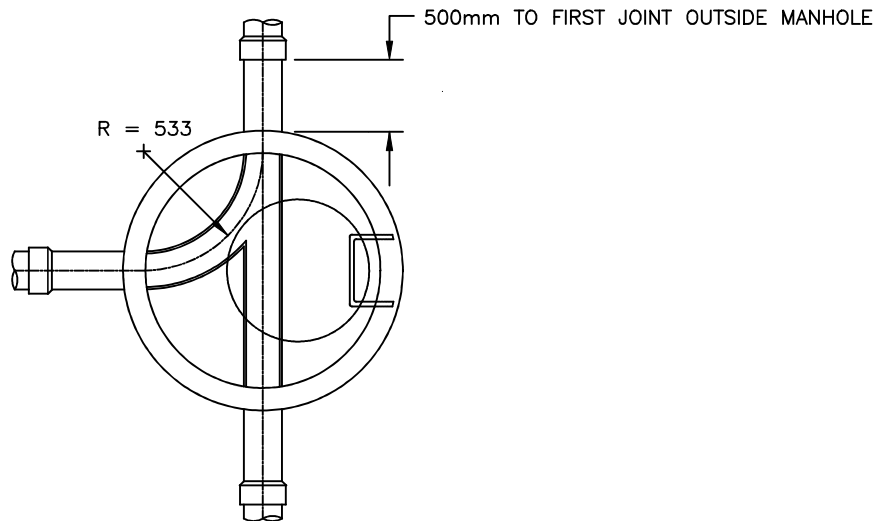

PLAN

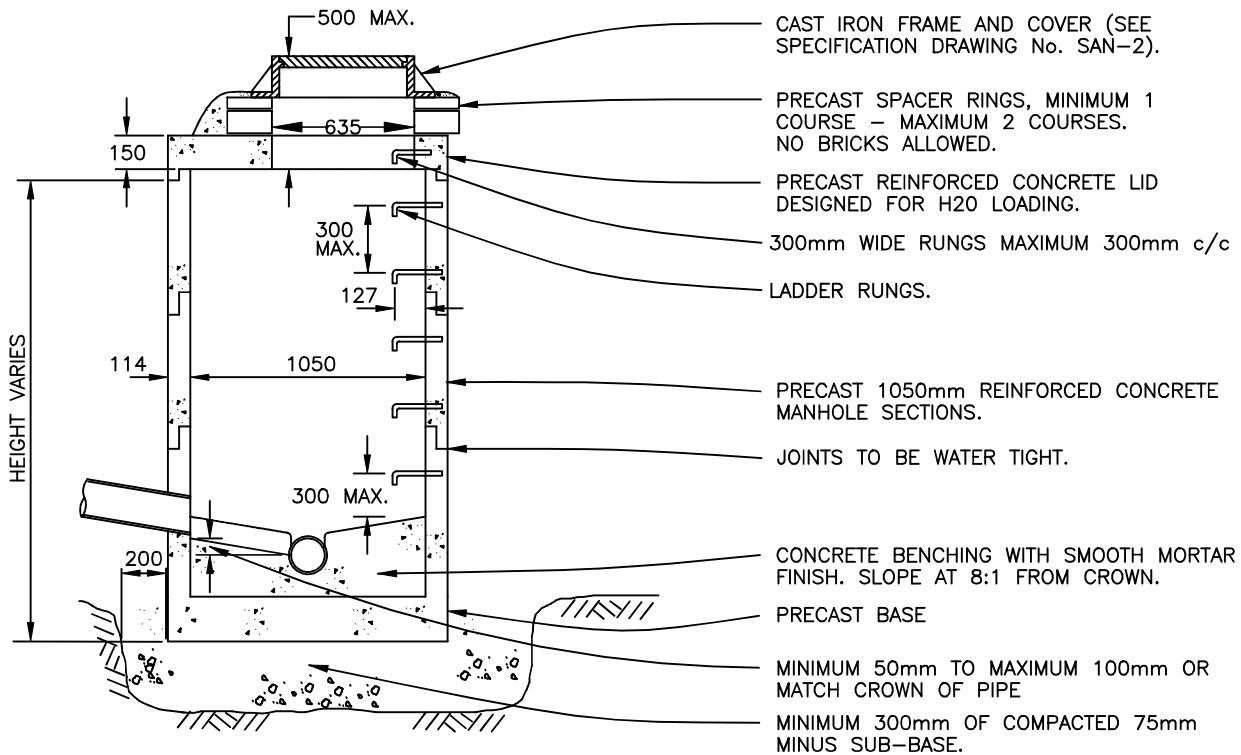

ELEVATION

NOTES:

- 1) Manhole sections, lid, spacer rings & any breaks made into manhole sections shall be made water tight with approved sealants or gaskets inside and out.
- 2) All joints to have smooth mortar finish.
- 3) Top of pipe running through manhole to be broken out.
- 4) Frame & cover to be set at 5mm below finished asphalt design grade and cross-fall.
- 5) 1200mm Manhole required for pipes larger than 600mm and/or number of pipes exceed allowable for 1050mm manhole.
- 6) No low profile cast iron frame allowed, unless approved by the City Engineer.

**CITY OF SALMON ARM**

No.	REVISION	Date
A	SDSB 4293 – ISSUED FOR APPROVAL	06/12/23

APPROVED



TYPICAL 1050mm SANITARY MANHOLE

SPECIFICATION DRAWING No.:

SAN-01

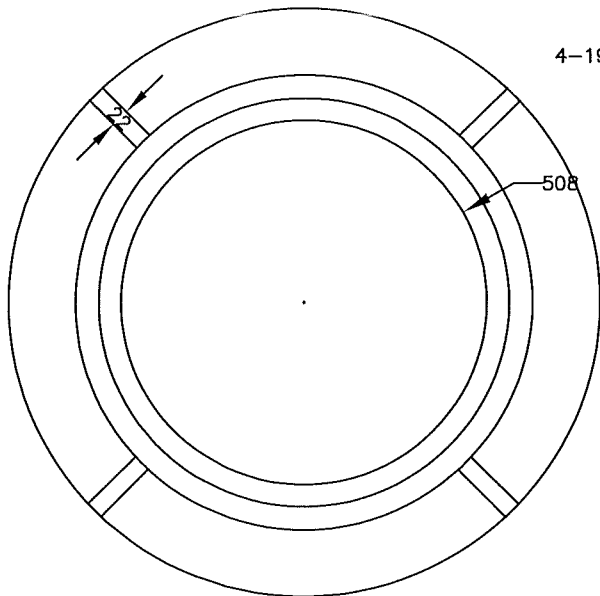

FRAME PLAN

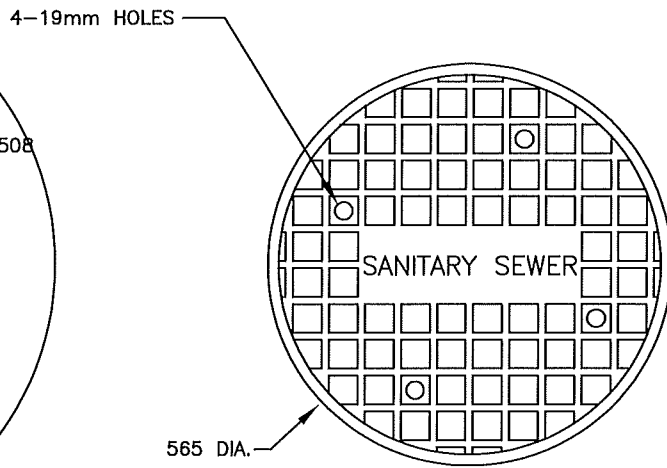

COVER PLAN

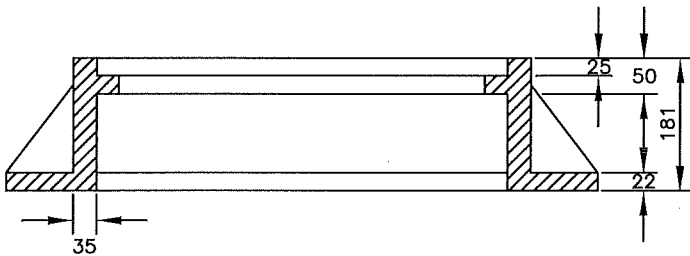

FRAME ELEVATION

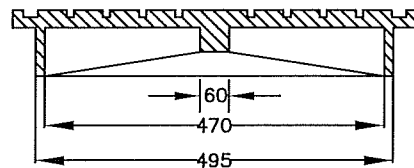

COVER ELEVATION

NOTES:

- 1) Frames and covers are to be designed to withstand H-20 loading.
- 2) Sanitary Sewer manhole covers shall be labelled: 'SANITARY SEWER'
- 3) No low profile cast iron frame allowed, unless approved by the City Engineer.
- 4) Bolt-down covers shall be used when directed by City Engineer.

**CITY OF SALMON ARM**

No.	REVISION	Date
A	SDSB 4293 – ISSUED FOR APPROVAL	06/12/23

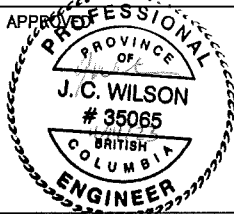

H-20 MANHOLE FRAME & COVER

SPECIFICATION  
DRAWING No.:

SAN-02

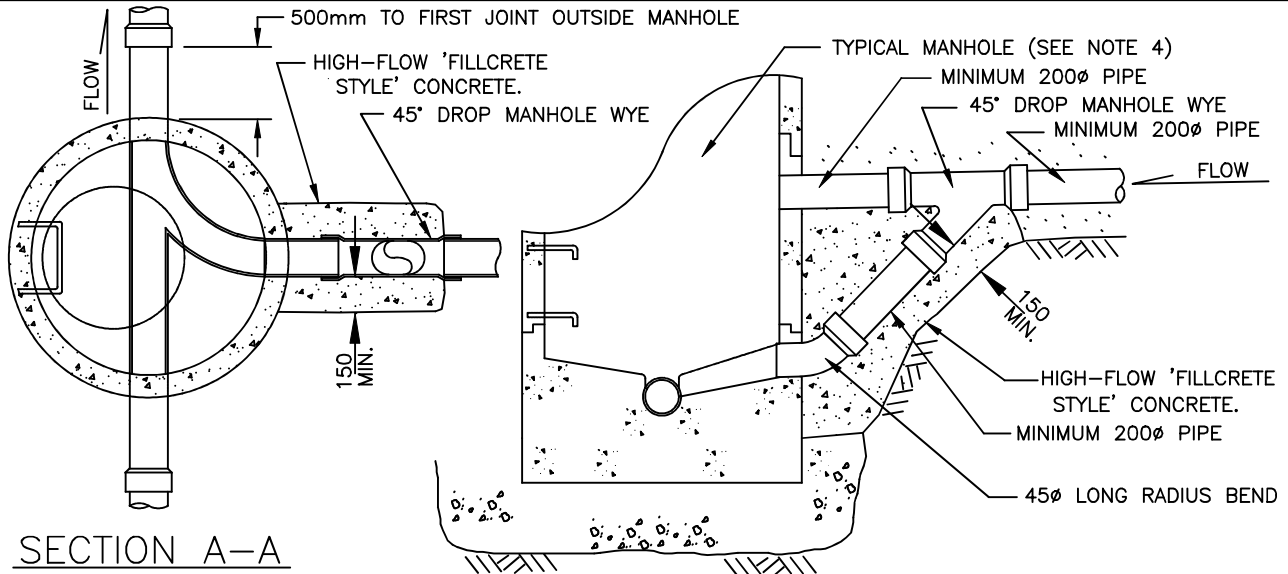

DROP LESS THAN 1500mm

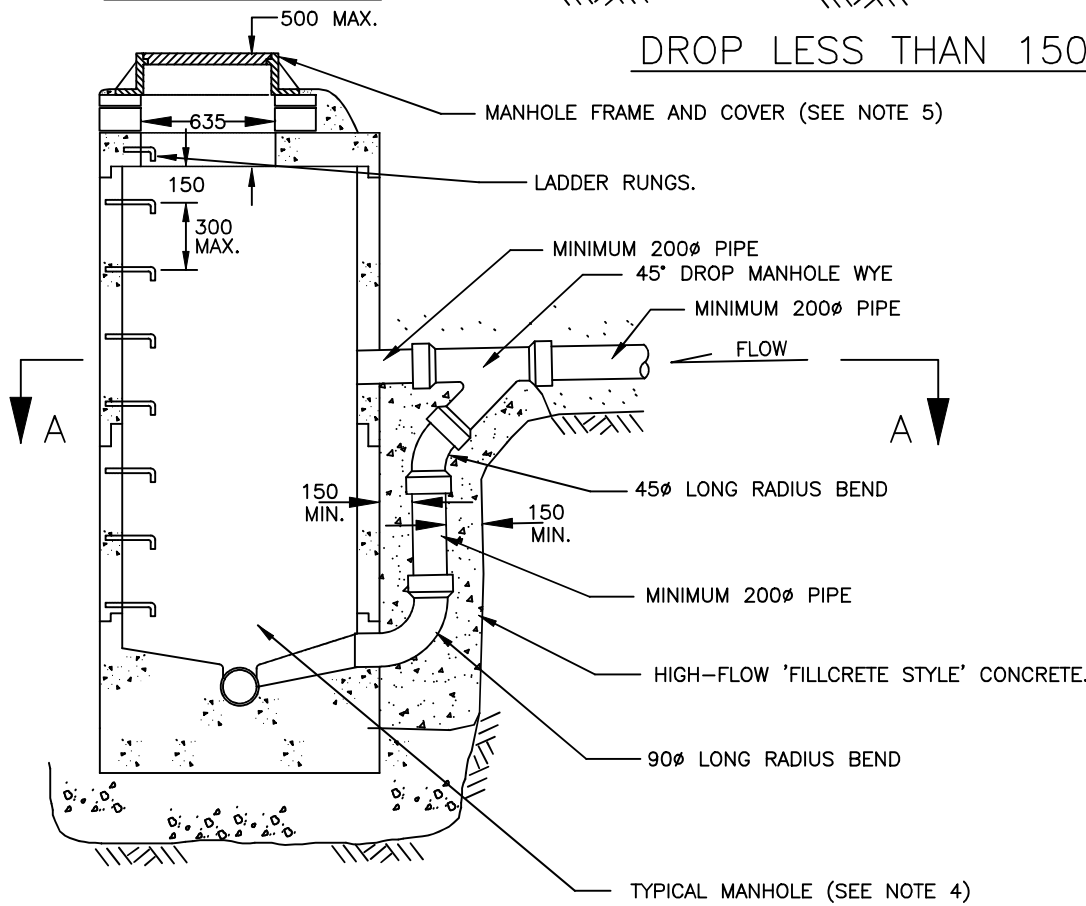

DROP GREATER THAN 1500mm

**NOTES:**

- 1) Inside ramps shall be utilized where the elevation of the invert is the same or below the crown of the through pipe (Refer to Specification Drawing San-1).
- 2) All joints to have smooth mortar finish.

- 3) Encasement Concrete strength to be high-flow 'fillcrete style' concrete.
- 4) Refer to Specification Drawing No. San-1, Typical 1050mm Sanitary Manhole.
- 5) Refer to Specification Drawing No. San-2, H-20 Manhole Frame & Cover.
- 6) Inside drop to be approved by the City Engineer.

<b>CITY OF SALMONARM</b>		
No.	REVISION	Date
A	SDSB 4293 – ISSUED FOR APPROVAL	06/12/23

APPROVED

TYPICAL 1050mm SANITARY DROP MANHOLE

SPECIFICATION DRAWING No.: SAN-03

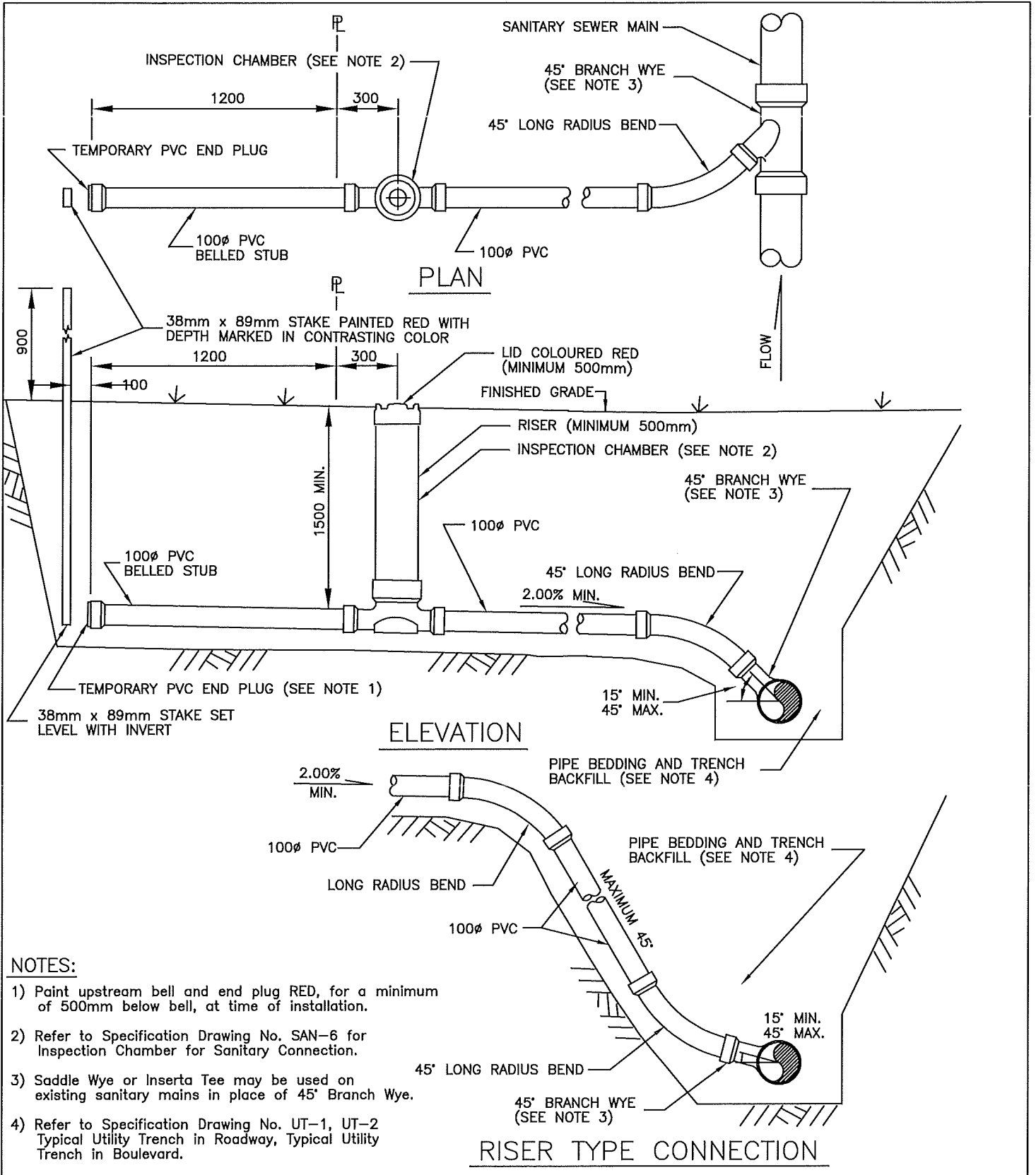

<b>CITY OF SALMON ARM</b>		
No.	REVISION	Date
A	SDSB 4293 – ISSUED FOR APPROVAL	06/12/23

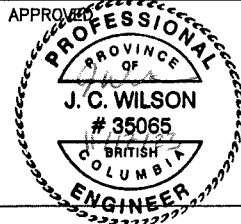

TYPICAL 100mm SANITARY SERVICE CONNECTION

SPECIFICATION DRAWING No.: SAN-04

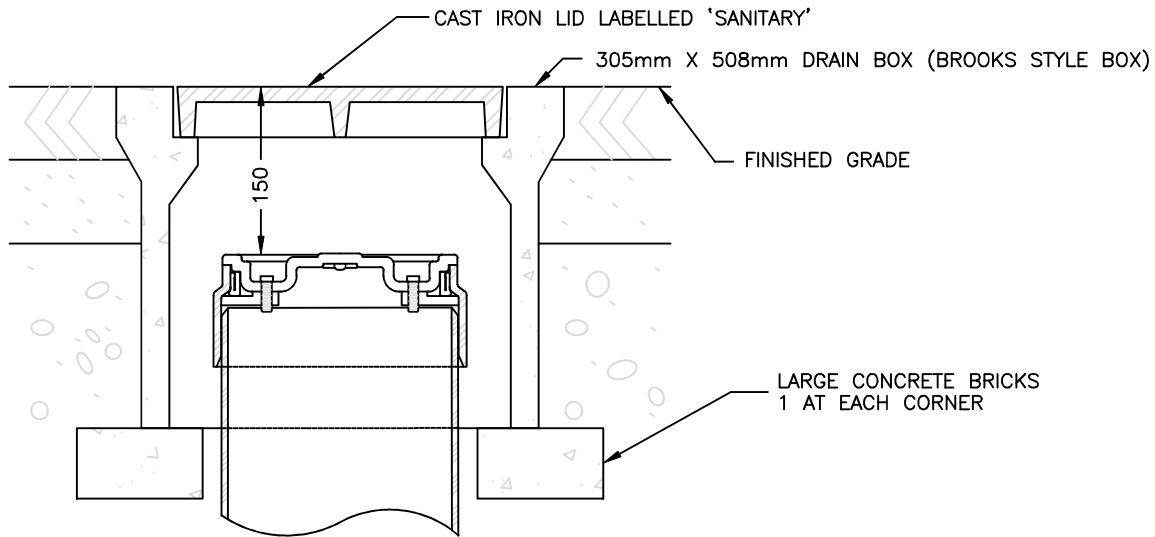

INSTALLATION w/ DRAIN BOX (BROOKS STYLE BOX)

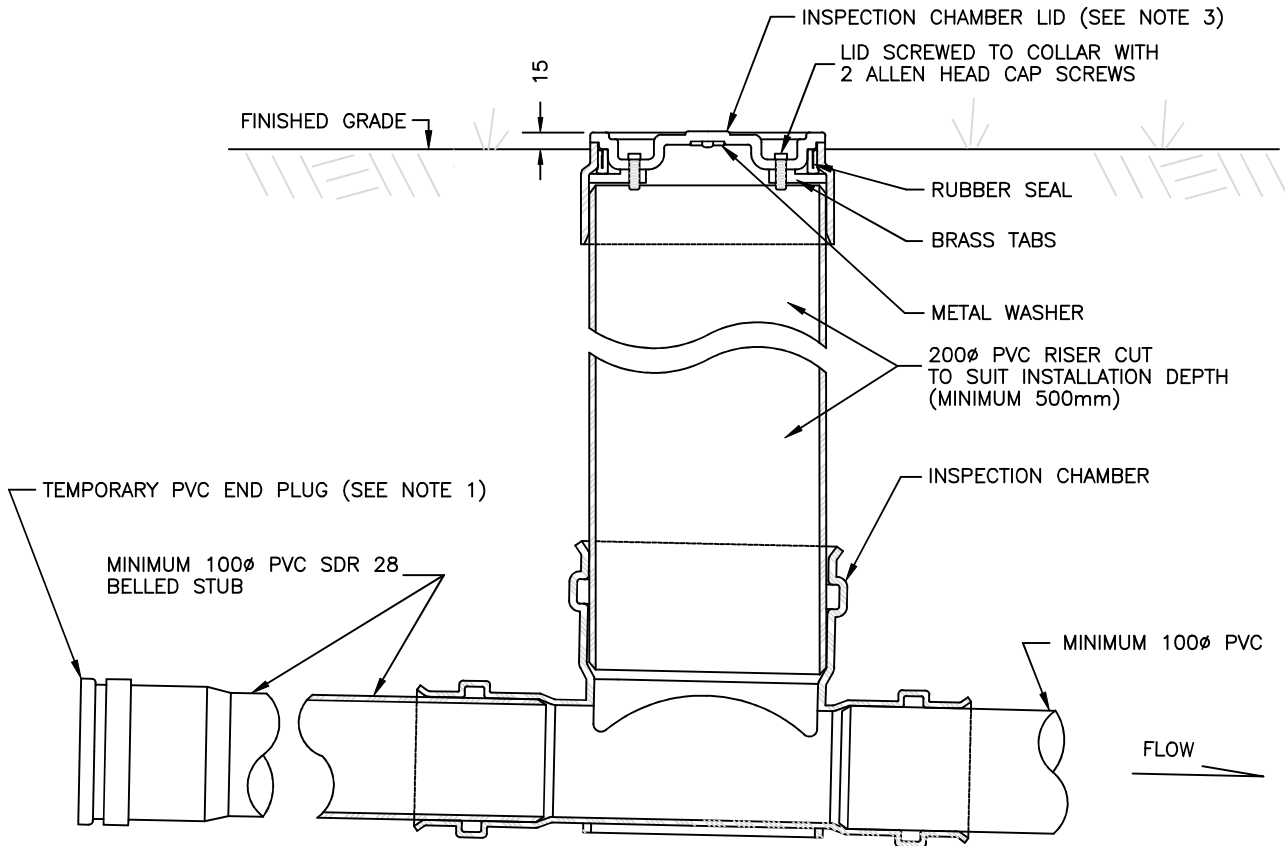

NOTES:

- 1) Paint upstream bell and end plug RED, for a minimum of 500mm below bell, at time of installation.
- 2) Refer to Specification Drawing No. SAN-4 Typical 100mm Sanitary Connection.
- 3) Inspection chamber lid to be coloured red.

**CITY OF SALMONARM**

No.	REVISION	Date
A	SDSB 4293 – ISSUED FOR APPROVAL	06/12/23

APPROVED



INSPECTION CHAMBER FOR  
SANITARY CONNECTION

SPECIFICATION  
DRAWING No.:

SAN-06

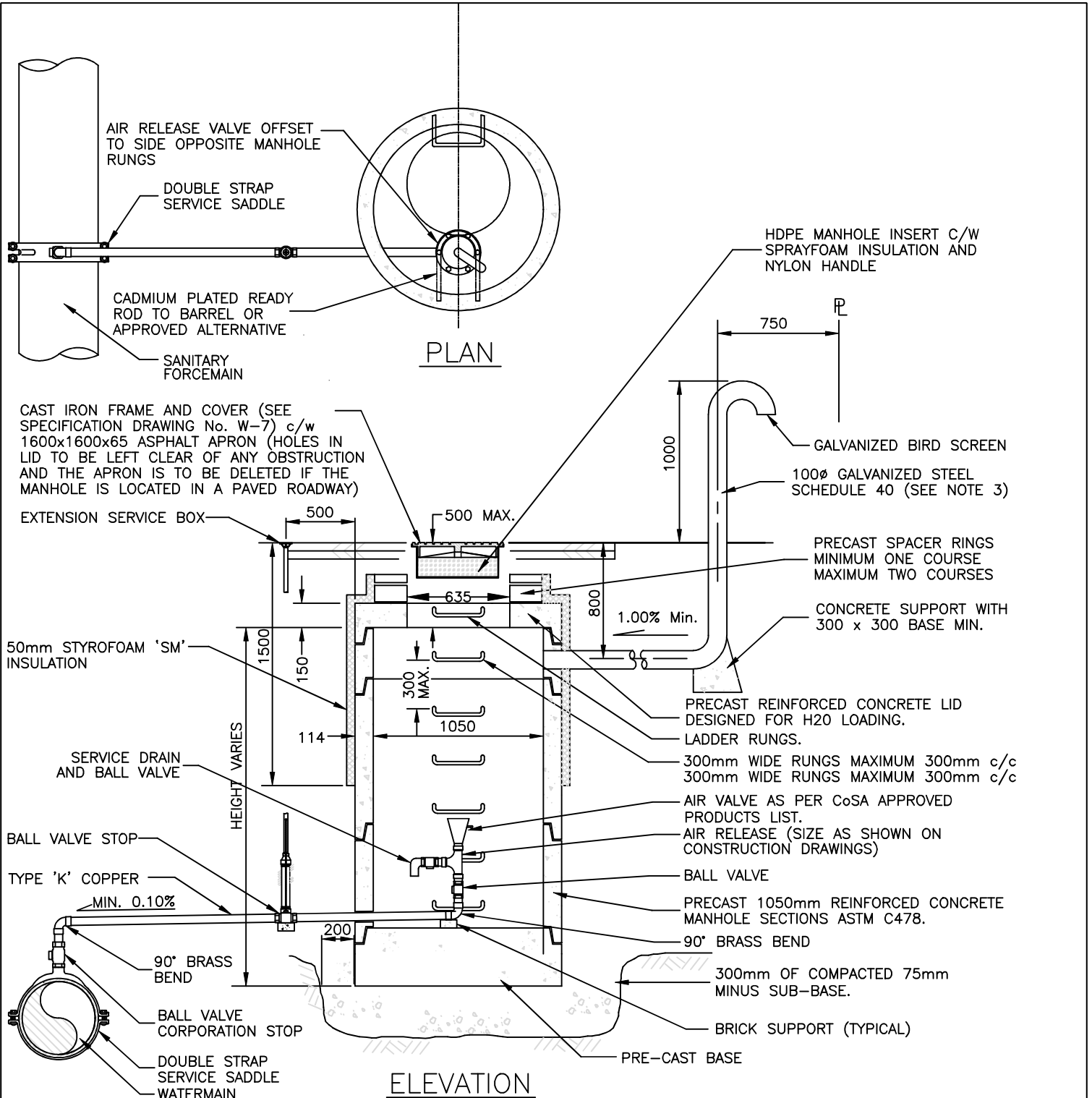

**NOTES:**

- 1) Frame & cover to be set at 5mm below finished asphalt design grade and cross-fall.
- 2) 100Ø vent to be used in rural areas only.
- 3) Combination Air Release where required by City Engineer.

PIPE SIZE (mm)	AIR RELEASE VALVE (mm)
200 AND SMALLER	25
250 TO 350	50
400 TO 500	75

<b>CITY OF SALMONARM</b>		
No.	REVISION	Date
A	SDSB 4293 – ISSUED FOR APPROVAL	06/12/23

APPROVED

AIR RELEASE VALVE – FORCEMAIN

SPECIFICATION DRAWING No.: SAN-07

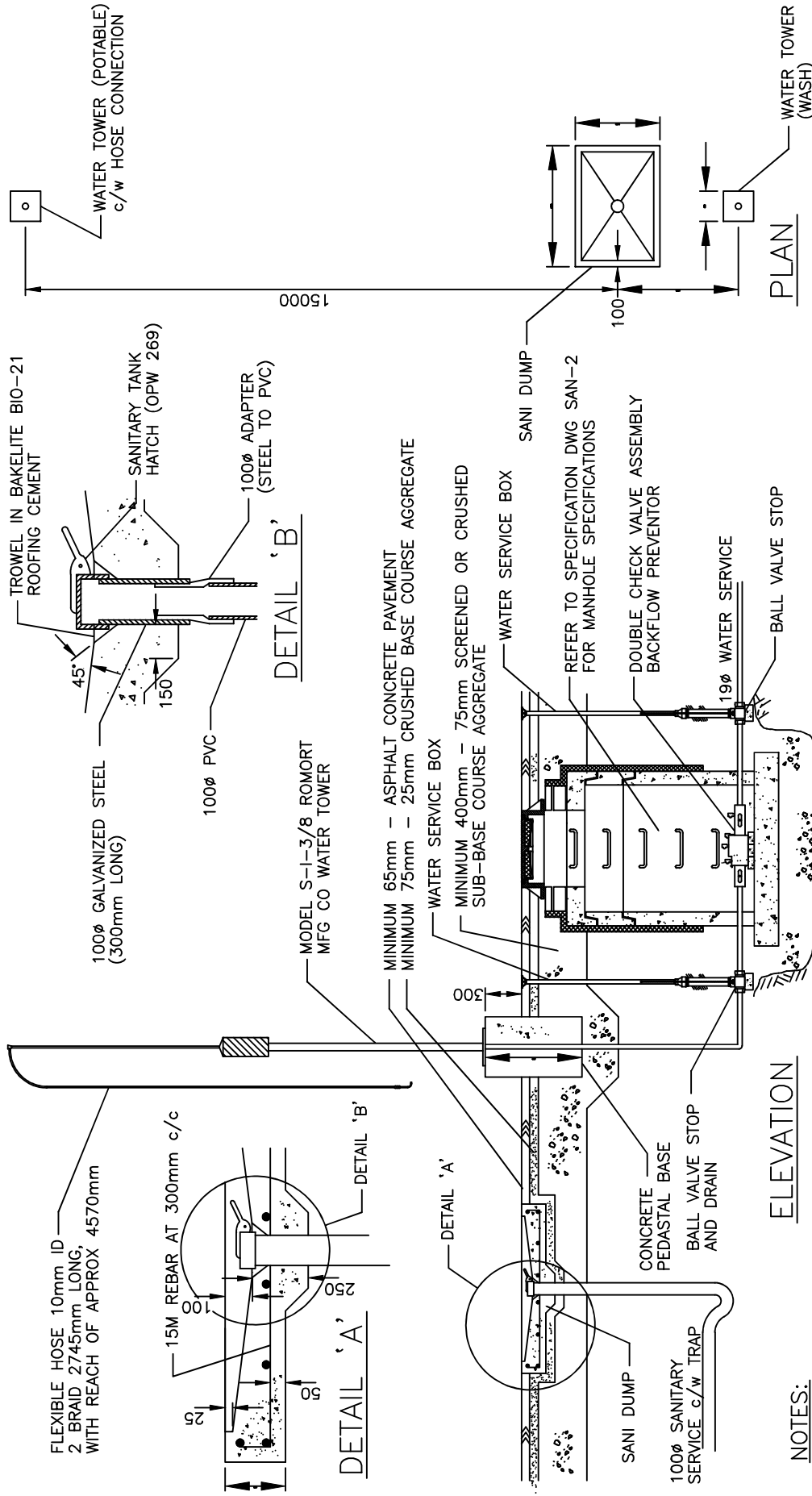

**NOTES:**

- 1) Concrete works shall be in accordance with CAN/CSA-A23.1-M94 & CAN/CSA-A23.2-M94 & CSA approved materials list.
- 2) Concrete shall be ready-mixed supplied by a company certified by the British Columbia Ready-Mix Concrete Association for conformance for Concrete Production Facilities.
- 3) Minimum compressive strength of 32MPa at 28 days.
- 4) Coarse aggregate of maximum size not exceeding 19mm.
- 5) Minimum cement content of 350 kg/m<sup>3</sup>.
- 6) Entrained air of 5 - 8%.
- 7) Slump: Between 10 - 25mm for monolithic. Maximum 65mm for poured on-place.
- 8) Maximum water - cement ratio of 0.45.



APPROVED

**SANITARY DUMP STATION**

No.	REVISION	Date
A	SDSB 4293 - ISSUED FOR APPROVAL	06/12/23

**CITY OF SALMON ARM**  
Permit to Practice: 1001265

SPECIFICATION DRAWING No.: SAN-08

SANITARY SEWER DESIGN

DESIGN SHEET \_\_\_\_\_  
FILE NO. \_\_\_\_\_  
PROJECT \_\_\_\_\_

(Harmon peaking factor where;  $2 \leq M \leq 4$ )  
(Peak population flow where;  $q=225 \text{ L/day/person}$ ;  $P=\text{population in thousands}$ )  
(Peak extraneous flow;  $I=0.1 \text{ L/s/ha}$  over development area)  
(Total peak flow as the sum of peak population flow and peak extraneous flow)

$n \geq 0.13$   
 $M = 1 + 1.14 / (4 + P^{0.5})$   
 $Q_p = P * q * M / 86.4$   
 $Q_{*A}$   
 $Q_{\text{tot}} = Q_p + Q_i$

STREET / AREA	MAINTENANCE HOLE		LAND USE	DEV. DENSITY (units/ha)	POP. DENSITY (ppu)	AREA (ha)	POP. (ACC)	M PEAKING FACTORS	Qp (L/S)	AREA (ACC) (ha)	Qi (L/S)	Qtot (L/S)	L (m)	D (mm)	S (%)	Q FULL (L/s)	V FULL (m/s)
	FROM	TO															

DATE: \_\_\_\_\_ CALCULATED BY: \_\_\_\_\_ CHECKED BY: \_\_\_\_\_

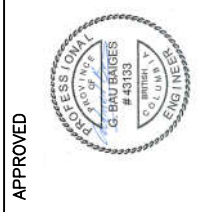

APPROVED

No.	REVISION	Date
A	SDSB 4293 - ISSUED FOR APPROVAL	06/12/23

SANITARY SEWER DESIGN SHEET

SPECIFICATION DRAWING No.: SAN-09



UTILITY RECORD

SUBDIVISION/ADDRESS		LEGAL DESCRIPTION		LOCATION PLAN	
SUBDIVISION: ADDRESS: WATER CONNECTION		LOT: PLAN: SEC: STORM CONNECTION			
DATE INSTALLED: INSTALLED BY: SIZE: MATERIAL: INV: LOCATION:		DATE INSTALLED: INSTALLED BY: SIZE: MATERIAL: * INV. ELEV. AT P/L: LOCATION:		<p>*MBE MINIMUM BASEMENT ELEVATION</p> <p>○ LOT GRADE (GEODETTIC)</p> <p>→ DIRECTION OF SURFACE RUNOFF</p> <p>Scale: 1:1000</p> <p>NOTE: THE INFORMATION CONTAINED HEREIN IS FOR INTERNAL USE ONLY AND IS NOT TO BE RELIED UPON UNLESS CONFIRMED BY SITE INSPECTION AND/OR INVESTIGATION.</p>	
SANITARY CONNECTION		NOTES		CONSULTANT NAME	
DATE INSTALLED: INSTALLED BY: SIZE: MATERIAL: * INV. ELEV. AT P/L: LOCATION:		DATE INSTALLED: INSTALLED BY: SIZE: MATERIAL: * INV. ELEV. AT P/L: LOCATION:		DATE INSTALLED: INSTALLED BY: SIZE: MATERIAL: * INV. ELEV. AT P/L: LOCATION:	
*GEODETTIC ELEVATION		*GEODETTIC ELEVATION		*GEODETTIC ELEVATION	

APPROVED



UTILITY SERVICE CARD

CITY OF <b>SALMON ARM</b>	No.	REVISION	Date
	A	SDSB 4293 – ISSUED FOR APPROVAL	06/12/23

SPECIFICATION  
DRAWING No.:

SC-1

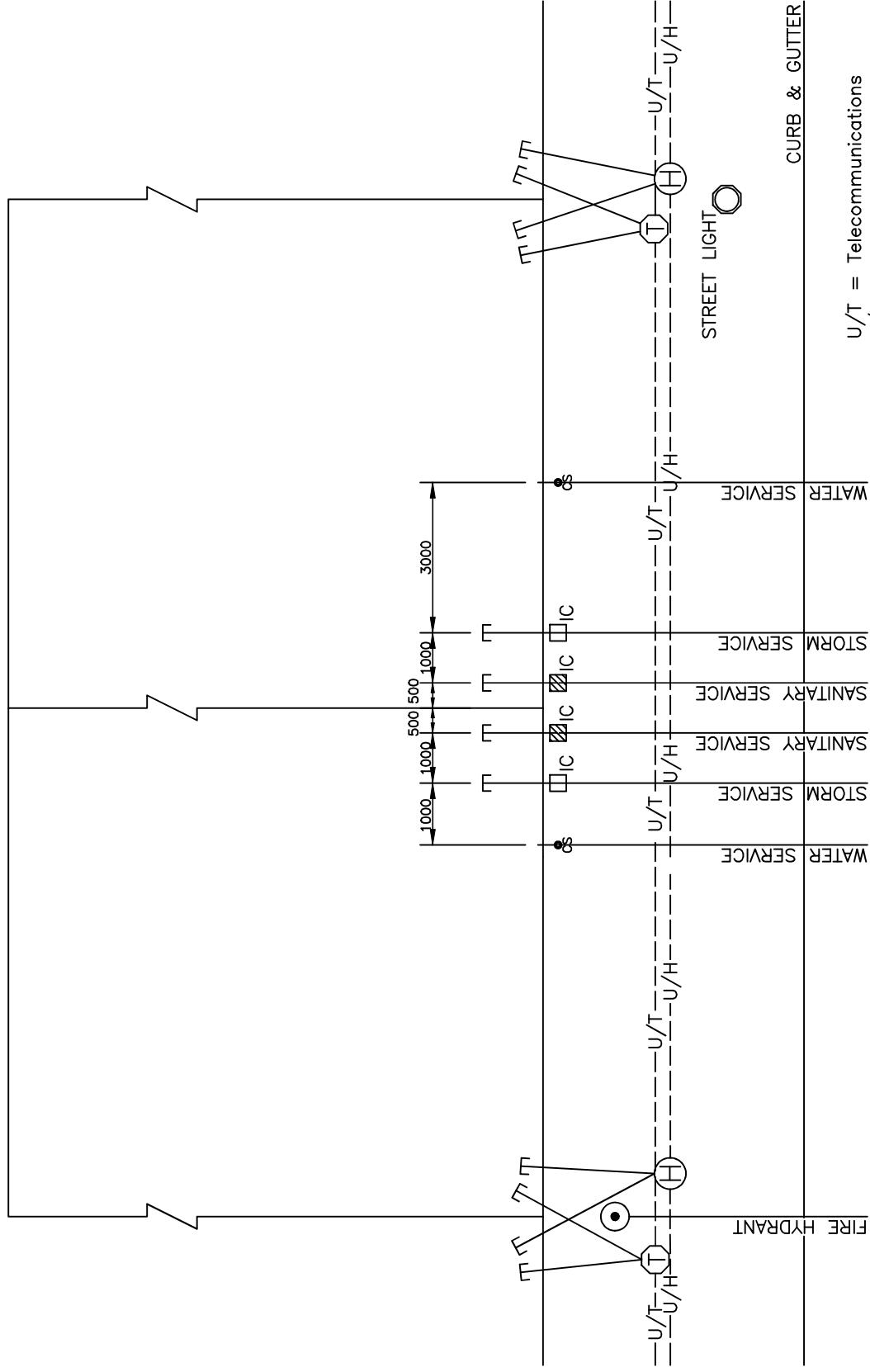

U/T = Telecommunications  
U/H = Hydro

- NOTES:**
- 1) Fire Hydrants are to be located at property corners.
  - 2) Hydro & Tel are to be located at property corners.
  - 3) Street lighting is to be located at property corners where existing and proposed utilities will allow.
  - 4) Services to be paired on PL where topography permits. Alternative service locations may be considered where site conditions warrant.

APPROVED

TYPICAL LOT SERVICING

<b>CITY OF</b> <b>SALMON ARM</b>	No.	REVISION	Date
	A	SDSB 4293 – ISSUED FOR APPROVAL	06/12/23

SPECIFICATION  
DRAWING No.:

SER-1

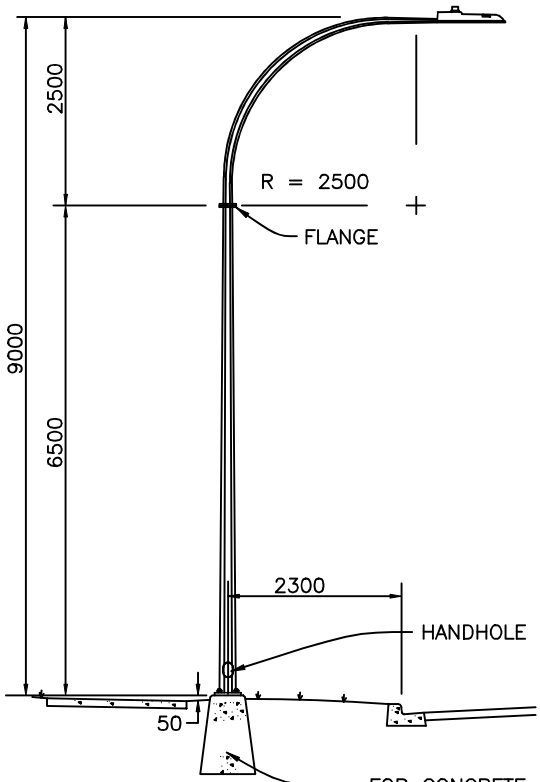

DAVIT STREET LIGHT

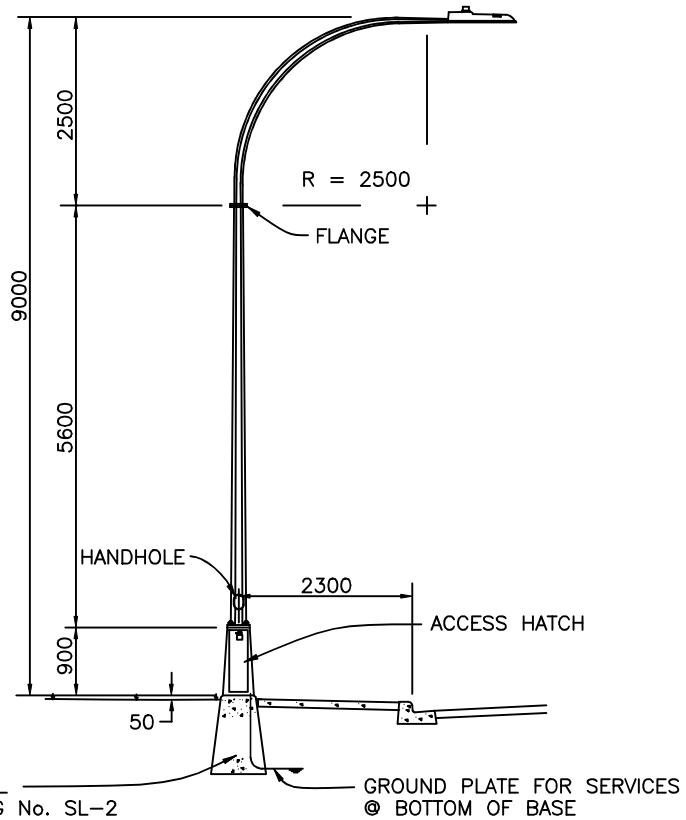

DAVIT STREET LIGHT  
c/w POWER BASE

NOTES:

- 1) Confirm bolt circle patterns with supplier.
- 2) Provide grounding to Canadian Electrical Code.
- 3) Light specifications shall conform to City of Salmon Arm approved materials list.
- 4) Any changes to the specifications must be approved by the City Engineer.
- 5) Access hatch to be located opposite to adjacent traffic flow.
- 6) Approved light sensor shall be installed on all fixtures.

<b>CITY OF SALMON ARM</b>		
No.	REVISION	Date
A	SDSB 4293 – ISSUED FOR APPROVAL	06/12/23

APPROVED

9.00m DAVIT STREET LIGHTS

SPECIFICATION DRAWING No.: SL-01

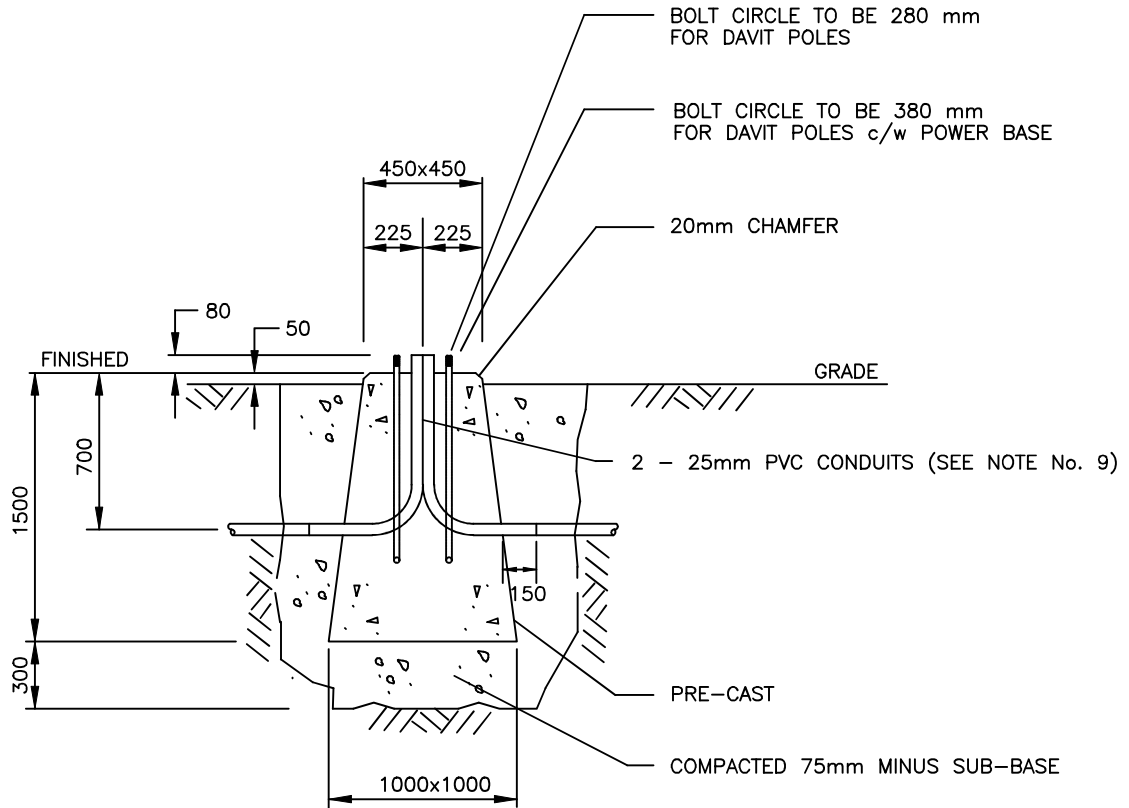

**NOTES:**

- 1) At last service base of duct run, install elbow and cap for future extension. (No exceptions.)
- 2) Provide additional 50mm duct to service base pole for BC Hydro service.
- 3) All hardware shall be hot dipped galvanized.
- 4) Apply Lubriplate or another suitable grease to exposed portion of anchor bolts and nuts.
- 5) Concrete shall have a compressive strength of 30 MPa prior to pole installation.
- 6) A 'V' groove drain trough to start at zero depth in centre of pedestal to a 10mm depth and width at the outside edge.
- 7) Confirm bolt circle pattern with supplier.
- 8) Anchor bolts to be: 4 - 25mm x 920mm hot dipped galvanized.
- 9) A 3rd - 25mm pvc conduit is needed for the ground wire on the power base.

**CITY OF SALMON ARM**

No.	REVISION	Date
A	SDSB 4293 – ISSUED FOR APPROVAL	06/12/23

APPROVED



9.00m DAVIT CONCRETE PEDESTAL

SPECIFICATION DRAWING No.:

SL-02

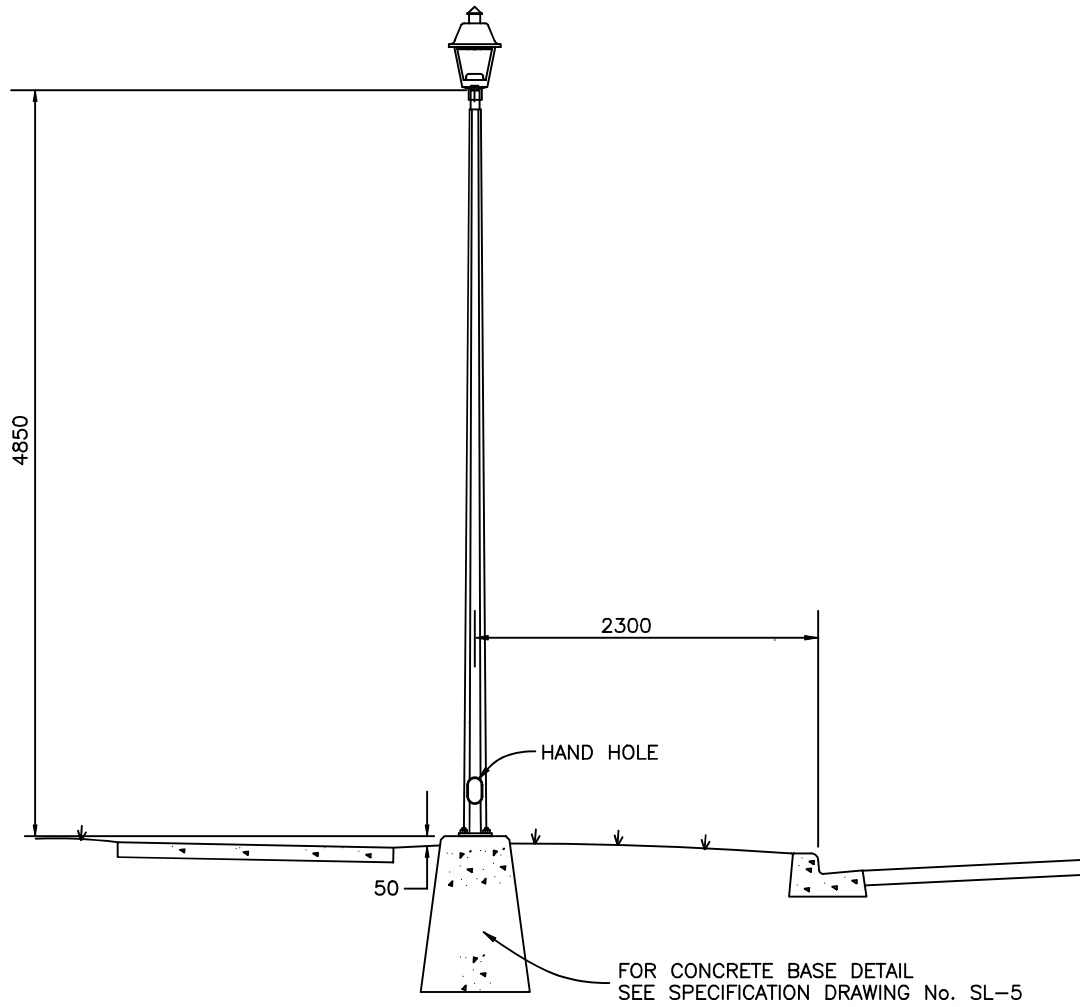

**NOTES:**

- 1) Confirm bolt circle pattern with supplier.
- 2) Provide grounding to Canadian Electrical Code.
- 3) Any changes to the specifications must be approved by the City Engineer.
- 4) Minimum Conductor Size #10.
- 5) Light specifications shall conform to City of Salmon Arm approved materials list.
- 6) Approved light sensor shall be installed on all fixtures.

**CITY OF SALMON ARM**

No.	REVISION	Date
A	SDSB 4293 – ISSUED FOR APPROVAL	06/12/23

APPROVED



POST TOP STREET LIGHT

SPECIFICATION DRAWING No.:

SL-03

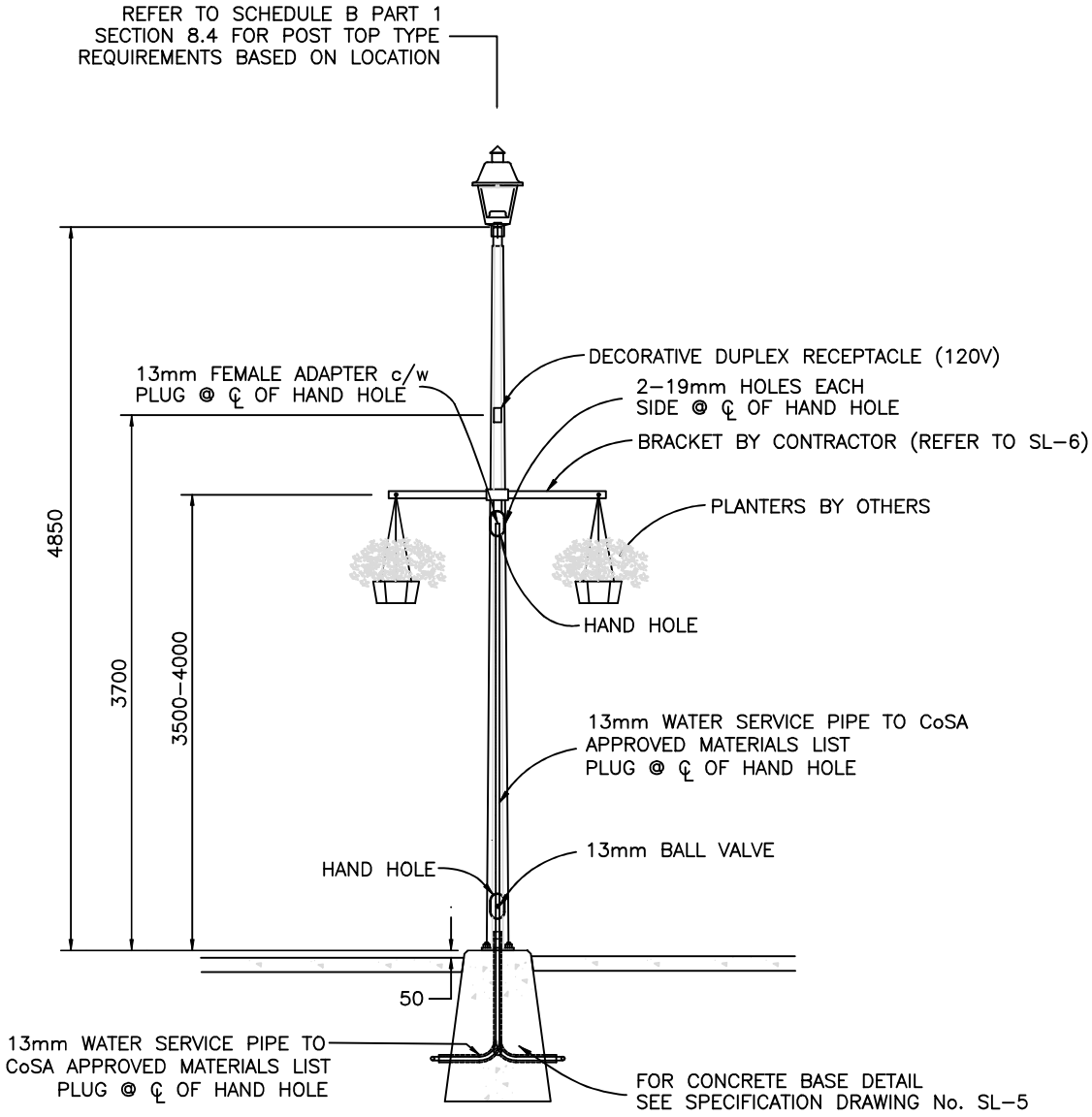

**NOTES:**

- 1) Confirm bolt circle pattern with supplier.
- 2) Provide grounding to Canadian Electrical Code.
- 3) Light specifications shall conform to City of Salmon Arm approved materials list.
- 4) Any changes to the specifications must be approved by the City Engineer.
- 5) Minimum Conductor Size #10.
- 6) Approved light sensor shall be installed on all fixtures.

**CITY OF SALMON ARM**

No.	REVISION	Date
A	SDSB 4293 – ISSUED FOR APPROVAL	06/12/23

APPROVED



POST TOP STREET LIGHT WITH IRRIGATION & ELECTRICAL OUTLET

SPECIFICATION DRAWING No.:

SL-3-1

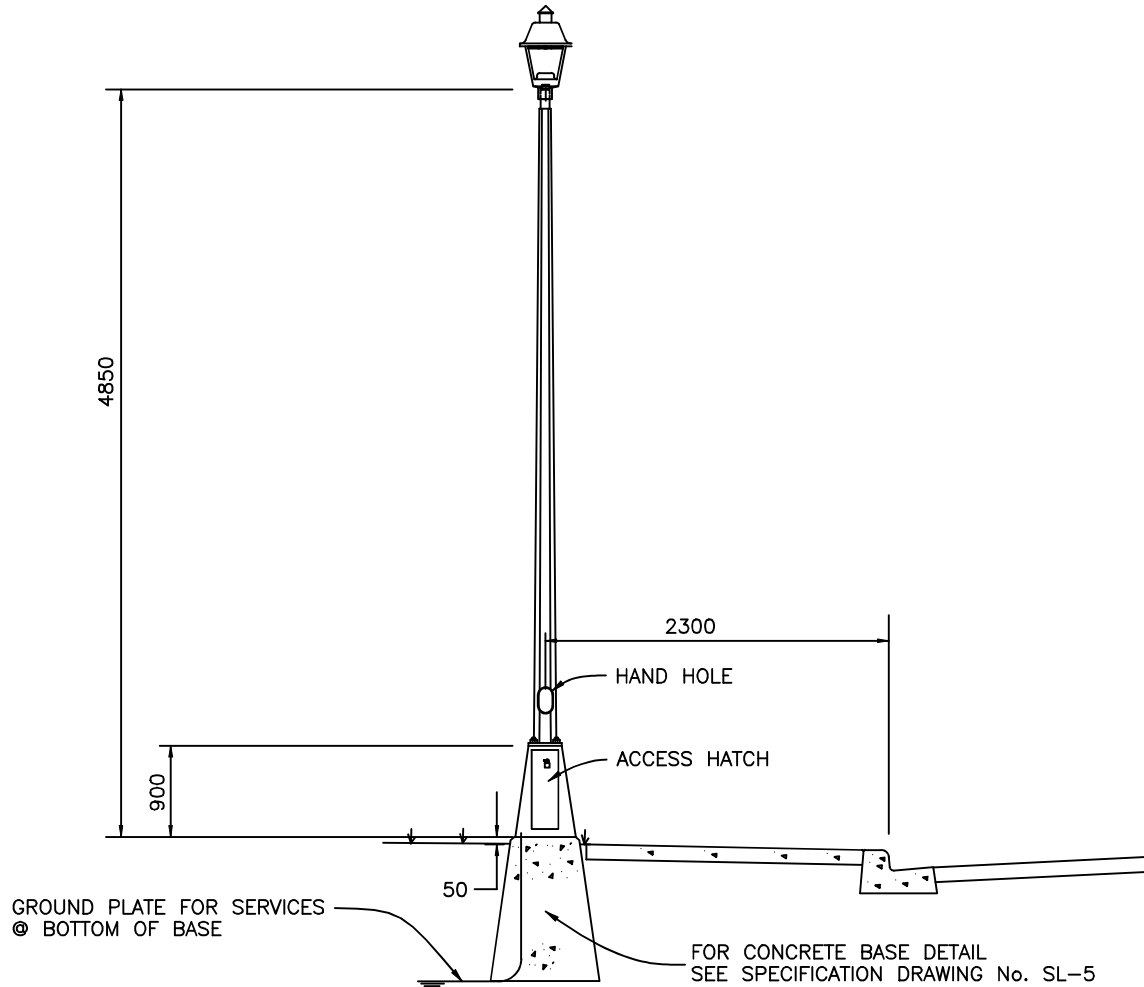

**NOTES:**

- 1) Confirm bolt circle pattern with supplier.
- 2) Provide grounding to Canadian Electrical Code.
- 3) Any changes to the specifications must be approved by the City Engineer.
- 4) Light specifications shall conform to City of Salmon Arm approved materials list.
- 5) Lighting and Tree Receptacles to be on separate circuits.
- 6) Minimum Conductor Size #10.
- 7) Access hatch to be located opposite to adjacent traffic flow.
- 8) Approved light sensor shall be installed on all fixtures.

<b>CITY OF SALMON ARM</b>		
No.	REVISION	Date
A	SDSB 4293 – ISSUED FOR APPROVAL	06/12/23

APPROVED

POST TOP STREET  
LIGHT/POWER BASE

---

SPECIFICATION  
DRAWING No.: SL-04

REFER TO SCHEDULE B PART 1  
SECTION 8.4 FOR POST TOP TYPE  
REQUIREMENTS BASED ON LOCATION

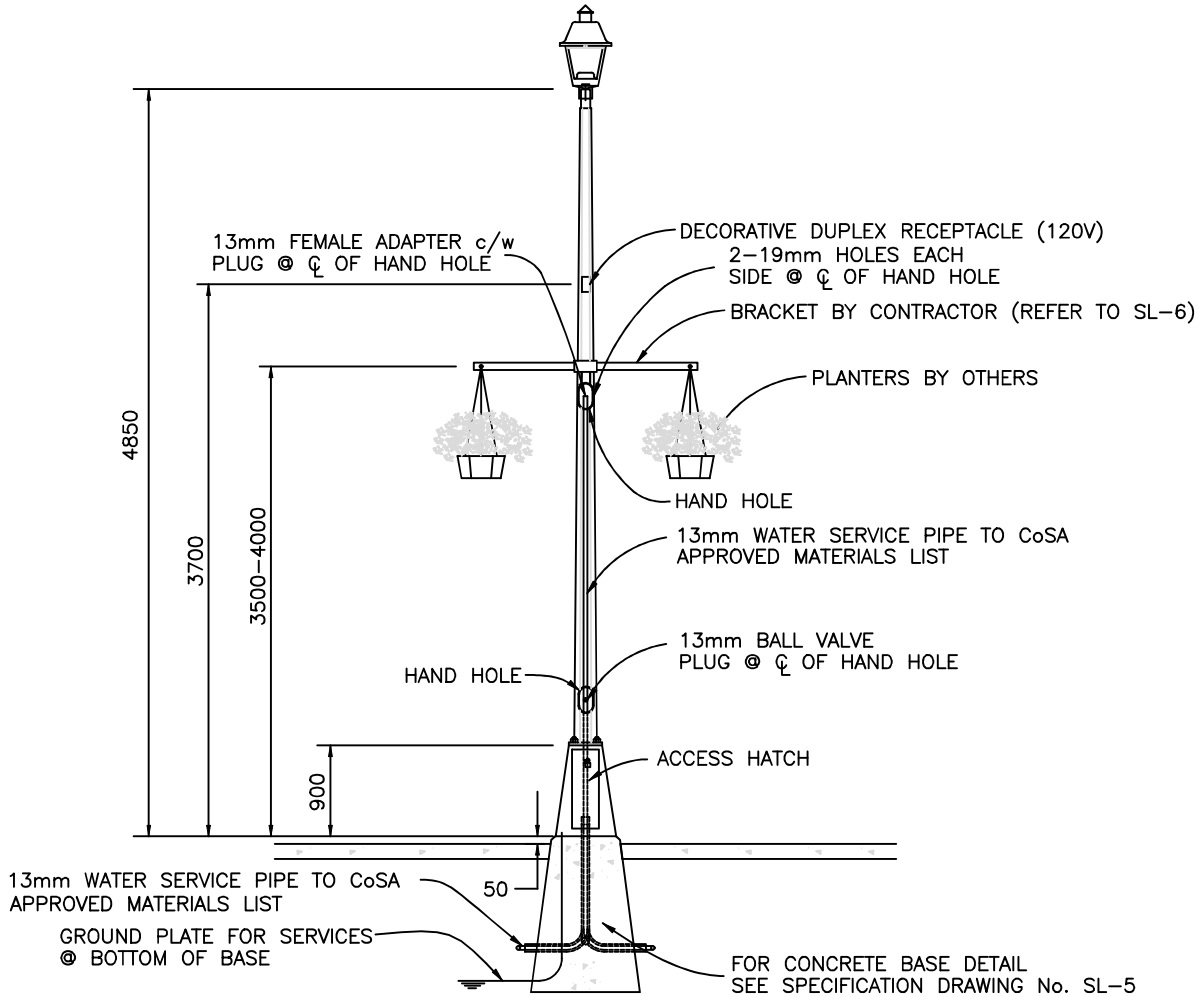

**NOTES:**

- 1) Confirm bolt circle pattern with supplier.
- 2) Provide grounding to Canadian Electrical Code.
- 3) Any changes to the specifications must be approved by the City Engineer.
- 4) Approved light sensor shall be installed on all fixtures.
- 5) Lighting and Tree Receptacles to be on separate circuits.
- 6) Minimum Conductor Size #10.
- 7) Light specifications shall conform to City of Salmon Arm approved materials list.
- 8) Access hatch to be located opposite to adjacent traffic flow.

<b>CITY OF SALMON ARM</b>		
No.	REVISION	Date
A	SDSB 4293 – ISSUED FOR APPROVAL	06/12/23

APPROVED

POST TOP STREET LIGHT/POWER  
BASE WITH IRRIGATION &  
ELECTRICAL OUTLET

SPECIFICATION  
DRAWING No.: SL-4-1



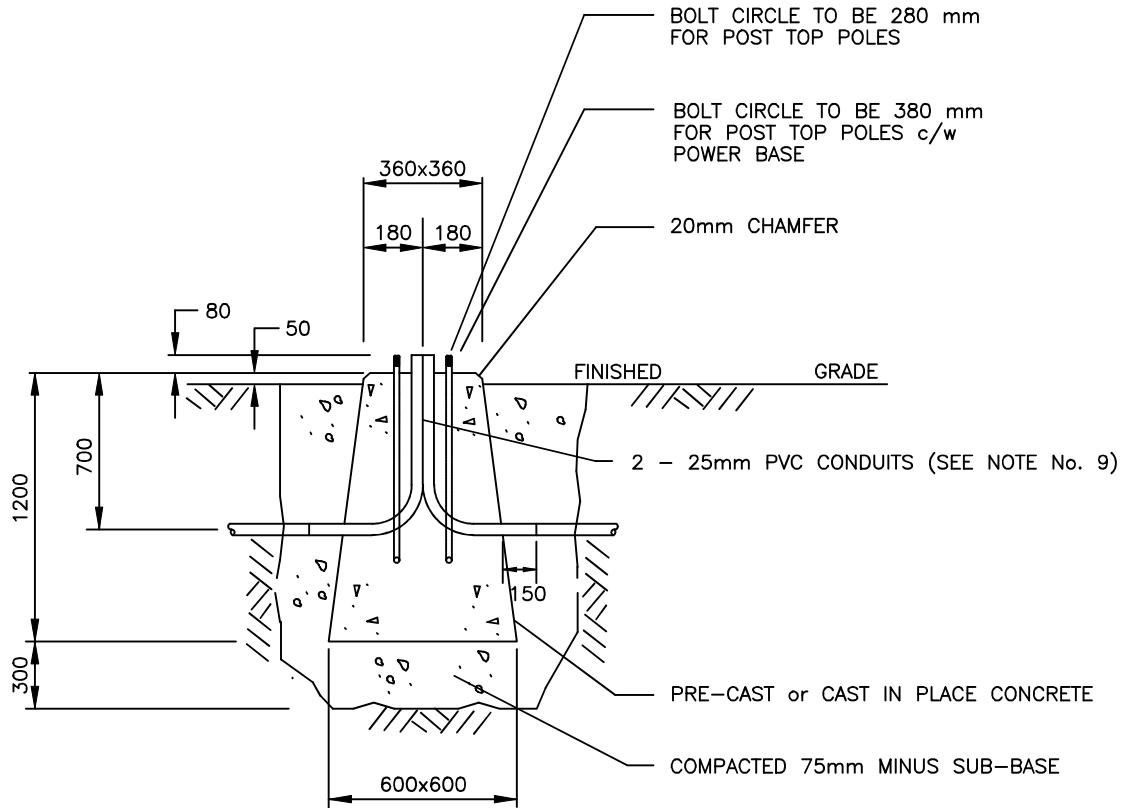

**NOTES:**

- 1) At last service base of duct run, install elbow and cap for future extension. (No exceptions.)
- 2) Provide additional 50mm duct to service base pole for BC Hydro service.
- 3) All hardware shall be hot dipped galvanized.
- 4) Apply Lubriplate or another suitable grease to exposed portion of anchor bolts and nuts.
- 5) Concrete shall have a comprehensive strength of 30 MPa prior to pole installation.
- 6) A 'V' groove drain trough to start at zero depth in centre of pedestal to a 10mm depth and width at the outside edge.
- 7) Confirm bolt circle pattern with supplier.
- 8) Anchor bolts to be: 4 - 25mm x 920mm hot dipped galvanized.
- 9) A 3rd - 25mm pvc conduit is needed for the ground wire on the power base.

**CITY OF SALMON ARM**

No.	REVISION	Date
A	SDSB 4293 – ISSUED FOR APPROVAL	06/12/23

APPROVED



5.00m POST TOP CONCRETE PEDESTAL

SPECIFICATION DRAWING No.:

SL-05

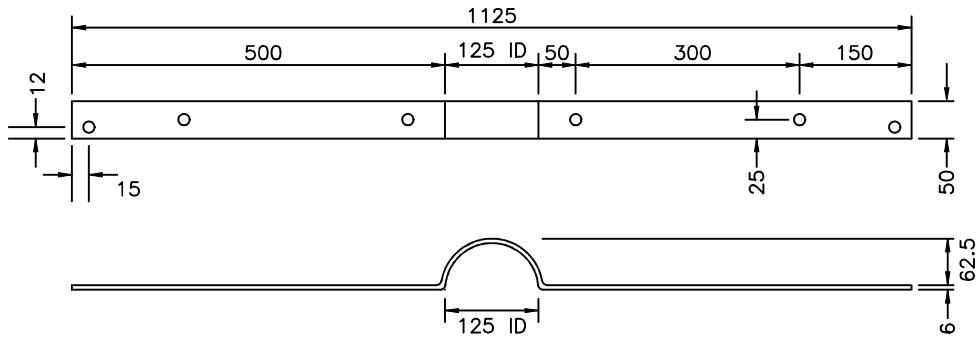

FRONT SIDE

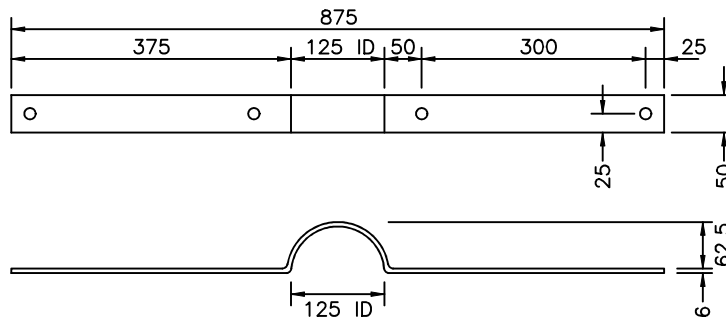

BACK SIDE

NOTES:

REFER TO DRAWING SL-3-I AND SL-4-I FOR BRACKET LOCATION.

SPECIFICATIONS:

BRACKET FINISH:

FACTORY POWDER COATING AS FOLLOWS:

- MIN. 2.5-4 mil OF EPOXY THERMOSETTING POWDER BASECOAT
- MIN. 4-6 mil OF BLACK POLYESTER THERMOSETTING POWDER TOPCOAT

BOLTS:

13 mm x 25 mm HOT DIPPED GALVANIZED c/w LOCK WASHER AND NUT

**CITY OF**  
**SALMON ARM**

No.	REVISION	Date
A	SDSB 4293 – ISSUED FOR APPROVAL	06/12/23

APPROVED



BRACKET FOR HANGING BASKETS

SPECIFICATION  
DRAWING No.:

SL-06

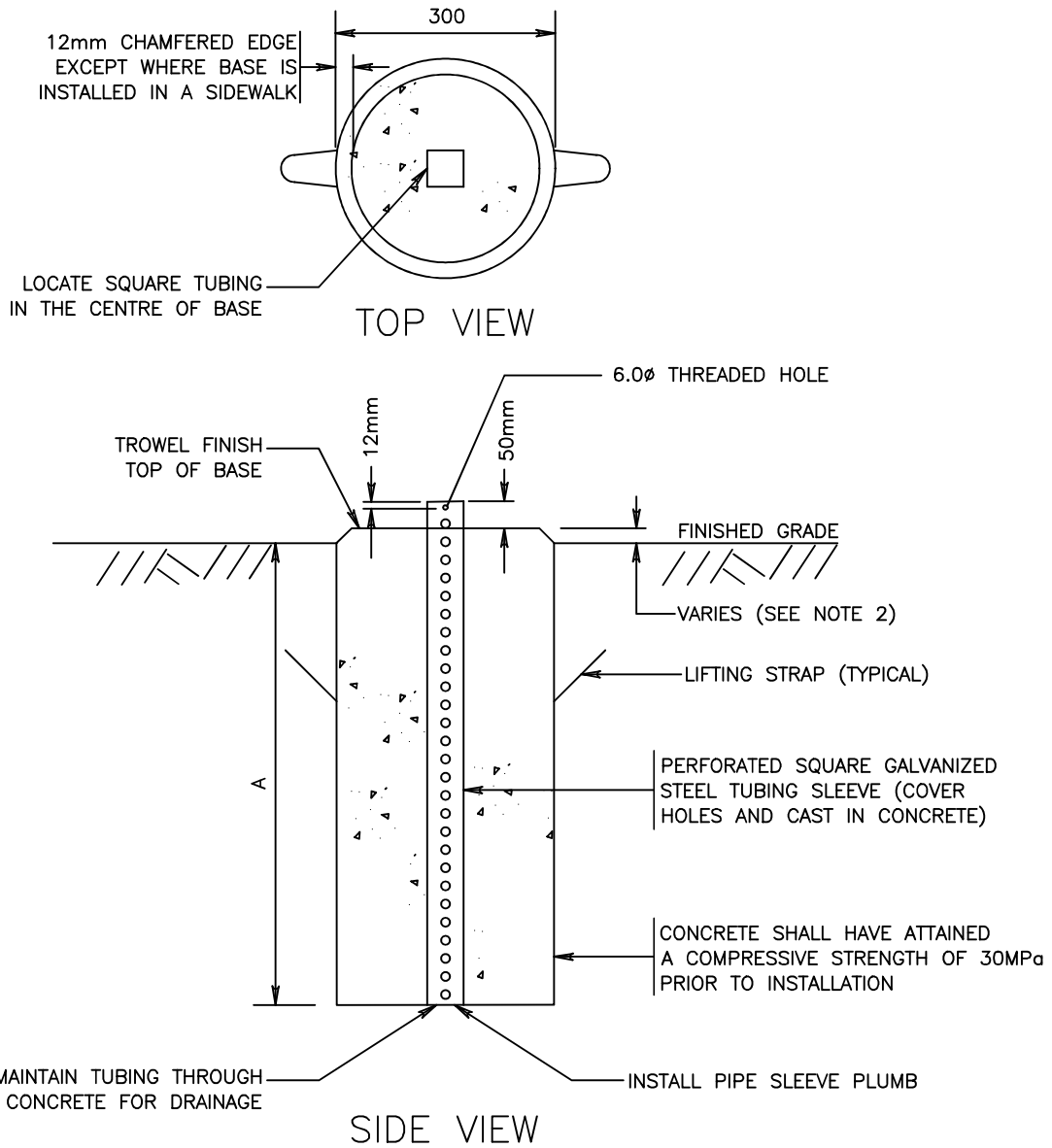

BASE TYPE	APPLICATION	APPROXIMATE MASS	VOLUME OF CONCRETE	A
1	SINGLE POST SIGNS IN PAVED ISLANDS OR CONCRETE SIDEWALKS (SIGNS $\leq 0.36m^2$ )	100kg	$0.04m^3$	600
2	SINGLE OR TWO POST SIGNS IN GRAVEL SHOULDER (SIGNS $> 0.36m^2$ )	147kg	$0.06m^3$	800

**NOTE:**

- 1) Parking signs to be placed at a 45° angle to the Curb & Gutter.
- 2) Base shall be installed 25mm above finished grade except where installed in sidewalk it shall be flush with the top of sidewalk with no chamfered edge.
- 3) Sign post to be 58mm 12 gauge steel. Sleeve to be 65mm 10 gauge steel.

<b>CITY OF SALMON ARM</b>		
No.	REVISION	Date
A	SDSB 4293 – ISSUED FOR APPROVAL	06/12/23

APPROVED

TYPICAL SIGN POST BASE

SPECIFICATION DRAWING No.: SP-01

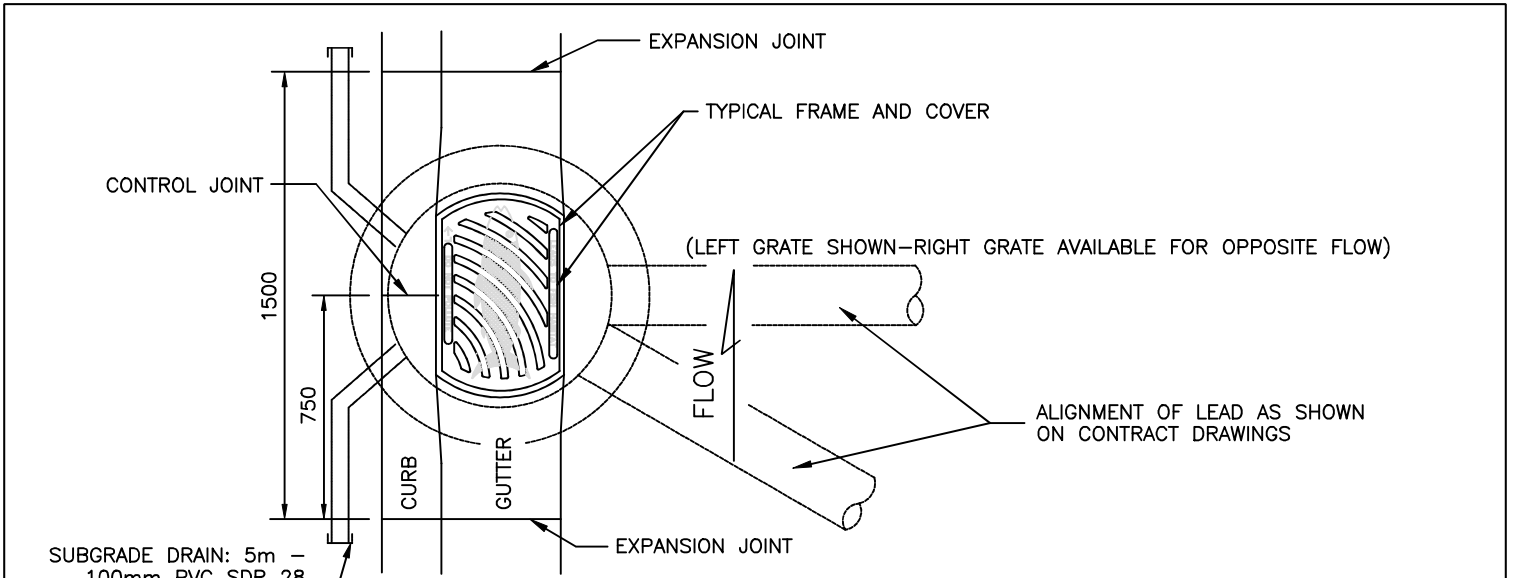

SUBGRADE DRAIN: 5m –  
100mm PVC SDR 28  
PERFORATED PIPE COMPLETE  
WITH 300mm X 300mm  
DRAIN ROCK WRAPPED IN  
FILTER CLOTH TIED INTO CB  
BARREL AND CAPPED AT  
ENDS. (TYP.)

PLAN

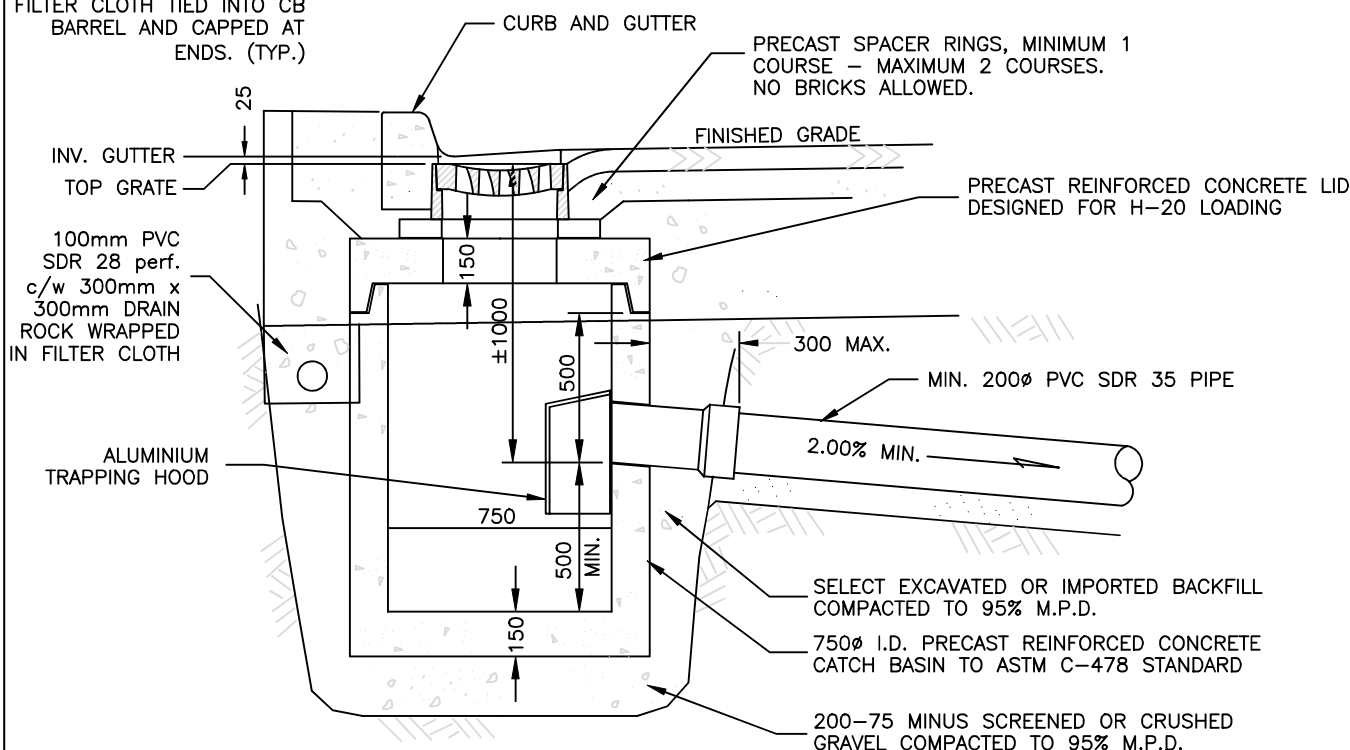

SECTION

NOTES:

- 1) Catch basin lid, precast spacer rings & any breaks made into catch basin sections shall be made water tight with approved mortar, sealants or gaskets inside and out.
- 2) All joints and spacer rings to have smooth mortar finish.
- 3) Outlet entry to be precored by supplier.
- 4) Frame & grate to be set at 25mm below finished gutter invert design grade.
- 5) Where CB falls at low point, install Subgrade Drain as detailed.

<b>CITY OF SALMON ARM</b>		
No.	REVISION	Date
A	SDSB 4293 – ISSUED FOR APPROVAL	06/12/23

APPROVED

CATCH BASIN – UNDER 5% GRADE

SPECIFICATION DRAWING No.: ST-1A

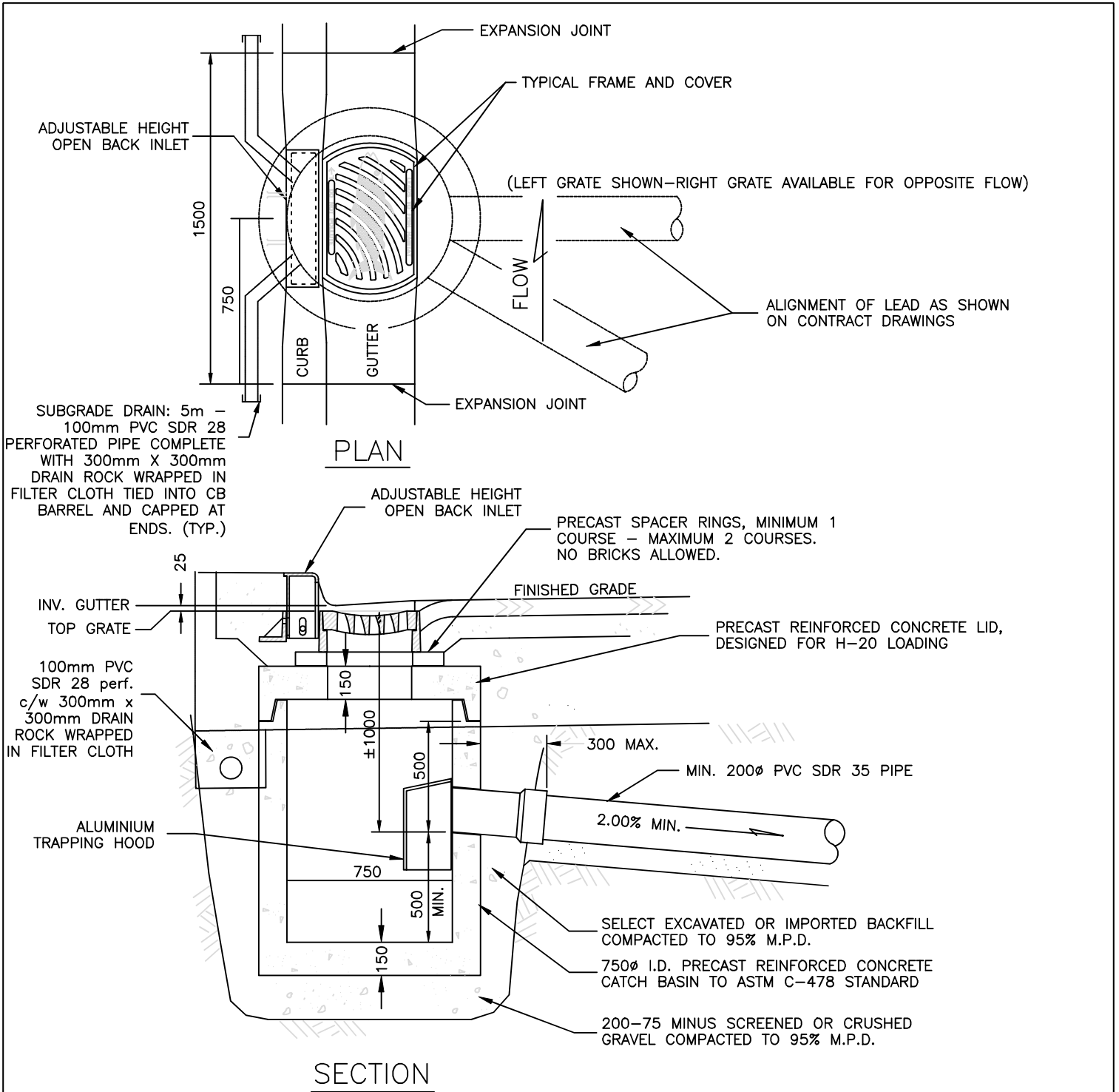

**NOTES:**

- 1) Catch basin lid, precast spacer rings & any breaks made into catch basin sections shall be made water tight with approved mortar, sealants or gaskets inside and out.
- 2) All joints and spacer rings to have smooth mortar finish.
- 3) Outlet entry to be precored by supplier.
- 4) Frame & grate to be set at 25mm below finished gutter invert design grade.
- 5) Where CB falls at low point, install Subgrade Drain as detailed.

<b>CITY OF SALMON ARM</b>		
No.	REVISION	Date
A	SDSB 4293 – ISSUED FOR APPROVAL	06/12/23

APPROVED

CATCH BASIN – OVER 5% GRADE

SPECIFICATION  
DRAWING No.: ST-1B

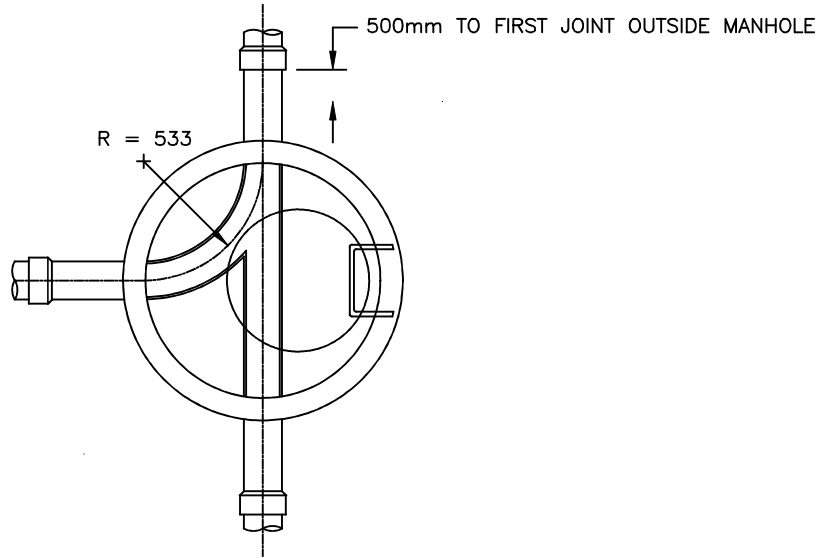

PLAN

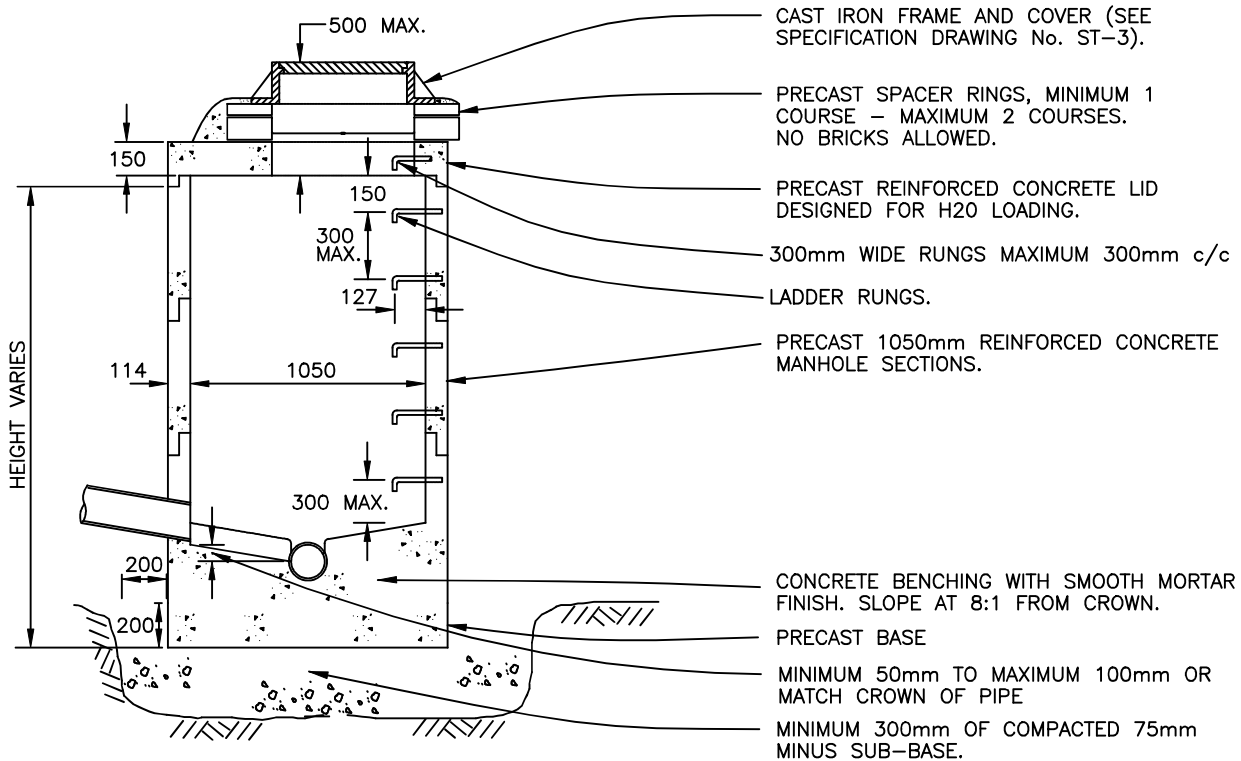

ELEVATION

NOTES:

- 1) Manhole sections, lid, spacer rings & any breaks made into manhole sections shall be made water tight with approved mortar, sealants or gaskets inside and out.
- 2) All joints to have smooth mortar finish.
- 3) Top of pipe running through manhole to be broken out.
- 4) Frame & cover to be set at 5mm below finished asphalt design grade and cross-fall.
- 5) 1200mm Manhole required for pipes larger than 600mm and/or number of pipes exceed allowable for 1050mm manhole.
- 6) Drop Manhole required where pipe enters a manhole at an elevation greater than the crown of the through pipe.
- 7) No low profile cast iron frame allowed, unless approved by the City Engineer.

<b>CITY OF SALMON ARM</b>		
No.	REVISION	Date
A	SDSB 4293 – ISSUED FOR APPROVAL	06/12/23

APPROVED

TYPICAL 1050mm STORM MANHOLE

SPECIFICATION DRAWING No.: ST-2

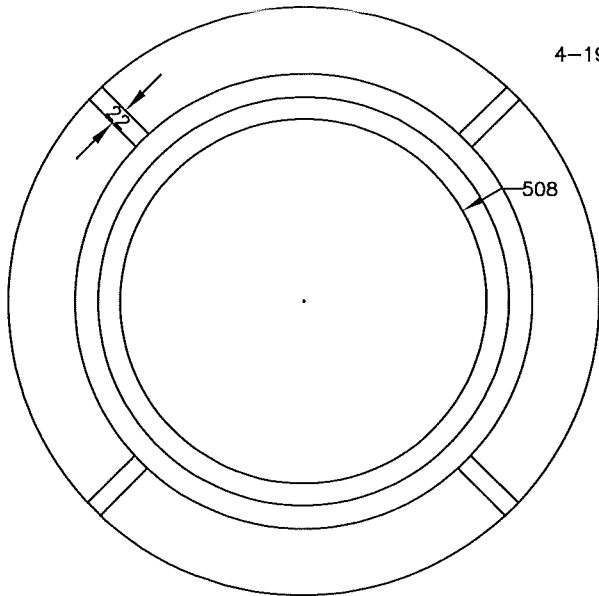

FRAME PLAN

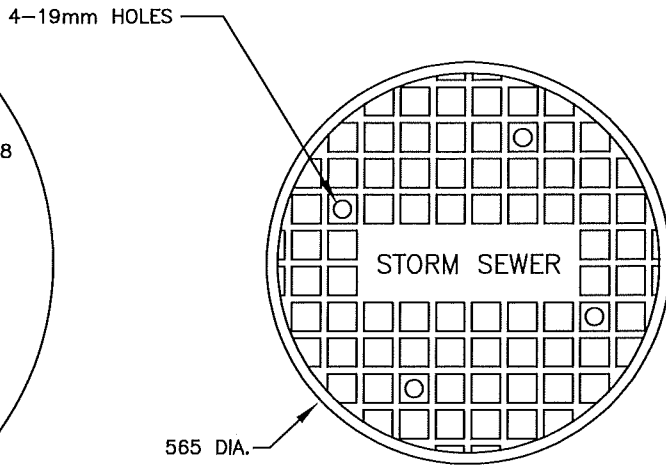

COVER PLAN

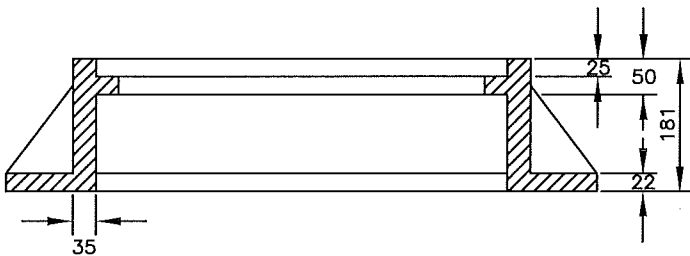

FRAME ELEVATION

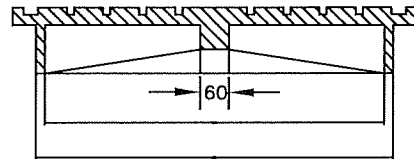

COVER ELEVATION

NOTES:

- 1) Frames and covers are to be designed to withstand H-20 loading.
- 2) Storm Sewer manhole covers shall be labelled: "STORM SEWER"
- 3) No low profile cast iron frame allowed, unless approved by the City Engineer.

**CITY OF SALMON ARM**

No.	REVISION	Date
A	SDSB 4293 – ISSUED FOR APPROVAL	06/12/23

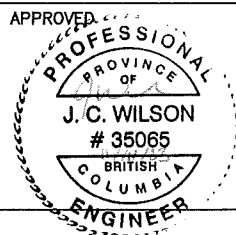

H-20 MANHOLE FRAME & COVER (STORM)

SPECIFICATION DRAWING No.:

ST-3

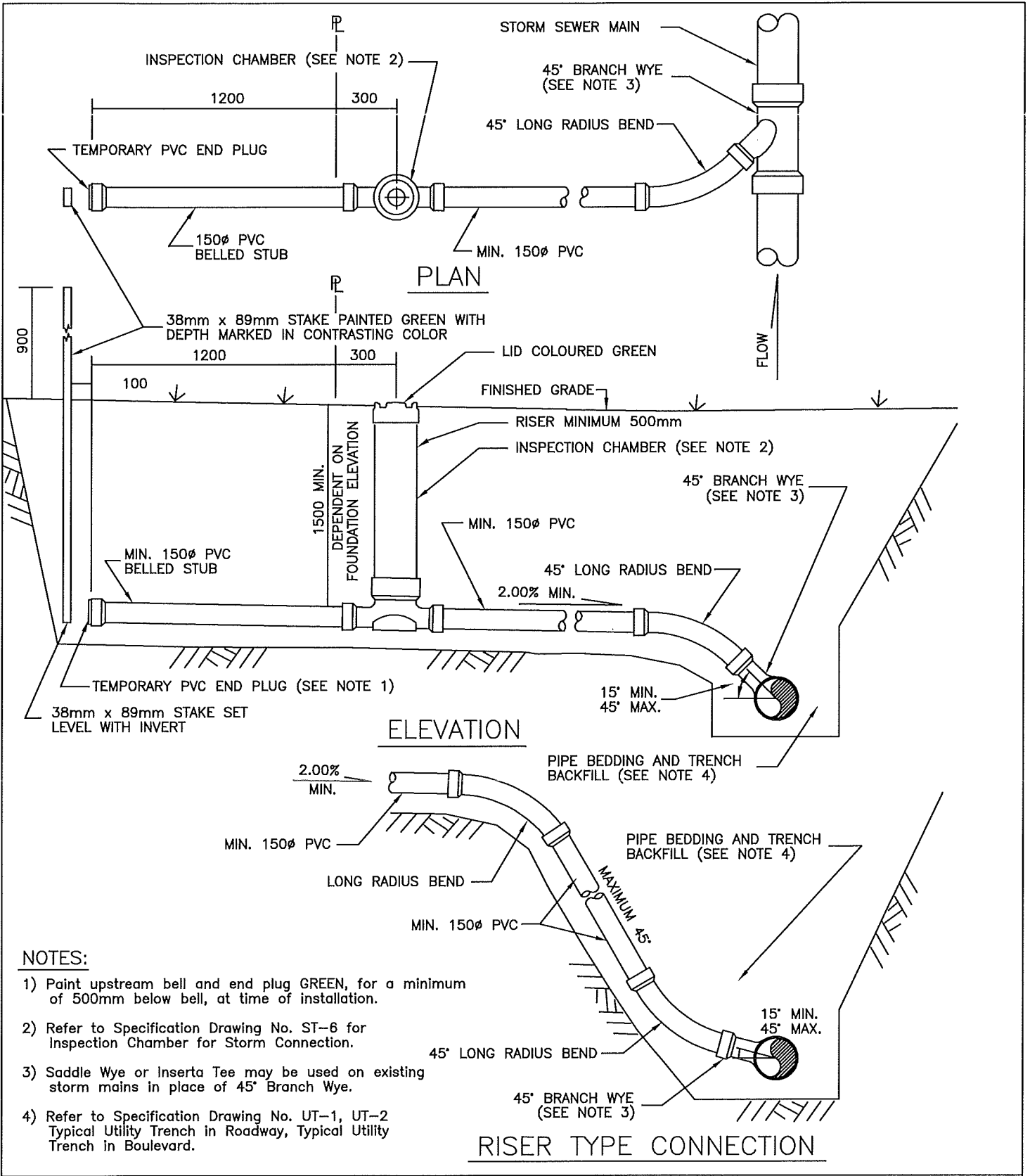

**NOTES:**

- 1) Paint upstream bell and end plug GREEN, for a minimum of 500mm below bell, at time of installation.
- 2) Refer to Specification Drawing No. ST-6 for Inspection Chamber for Storm Connection.
- 3) Saddle Wye or Inserta Tee may be used on existing storm mains in place of 45° Branch Wye.
- 4) Refer to Specification Drawing No. UT-1, UT-2 Typical Utility Trench in Roadway, Typical Utility Trench in Boulevard.

<b>CITY OF SALMON ARM</b>		
No.	REVISION	Date
A	SDSB 4293 – ISSUED FOR APPROVAL	06/12/23

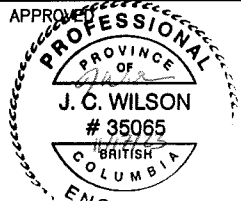

TYPICAL 150mm STORM SERVICE CONNECTION

SPECIFICATION DRAWING No.: ST-4



		SIZE OF SERVICE					
		8" 200mm	10" 250mm	12" 300mm	15" 375mm		
SIZE OF MAIN	8" 200mm			NOT APPLICABLE			
	10" 250mm						
	12" 300mm						
	15" 375mm						
	18" 450mm	MANHOLE REQUIRED ON MAIN					
	21" 525mm						
	24" 600mm						
	27" 675mm						
	30" 750mm						
	33" 825mm						
	36" 900mm			MANHOLE REQUIRED AT P			
	42" 1050mm						
	48" 1200mm						
	54" 1350mm						

**NOTES:**

- 1) Where Catch Basins are located within road right-of-way the Catch Basin leads do not require manholes at the storm main.
- 2) Inspection Chamber required at property for 150mm(6") services.
- 3) Services 450mm(18") and larger require approval by the City Engineer.
- 4) Manhole Frame and Cover required for 250mm(10") & 300mm(12") services in Driveways.

**CITY OF SALMON ARM**

No.	REVISION	Date
A	SDSB 4293 – ISSUED FOR APPROVAL	06/12/23

APPROVED



MANHOLE REQUIREMENTS FOR STORM SEWER SERVICES

SPECIFICATION DRAWING No.:

ST-5

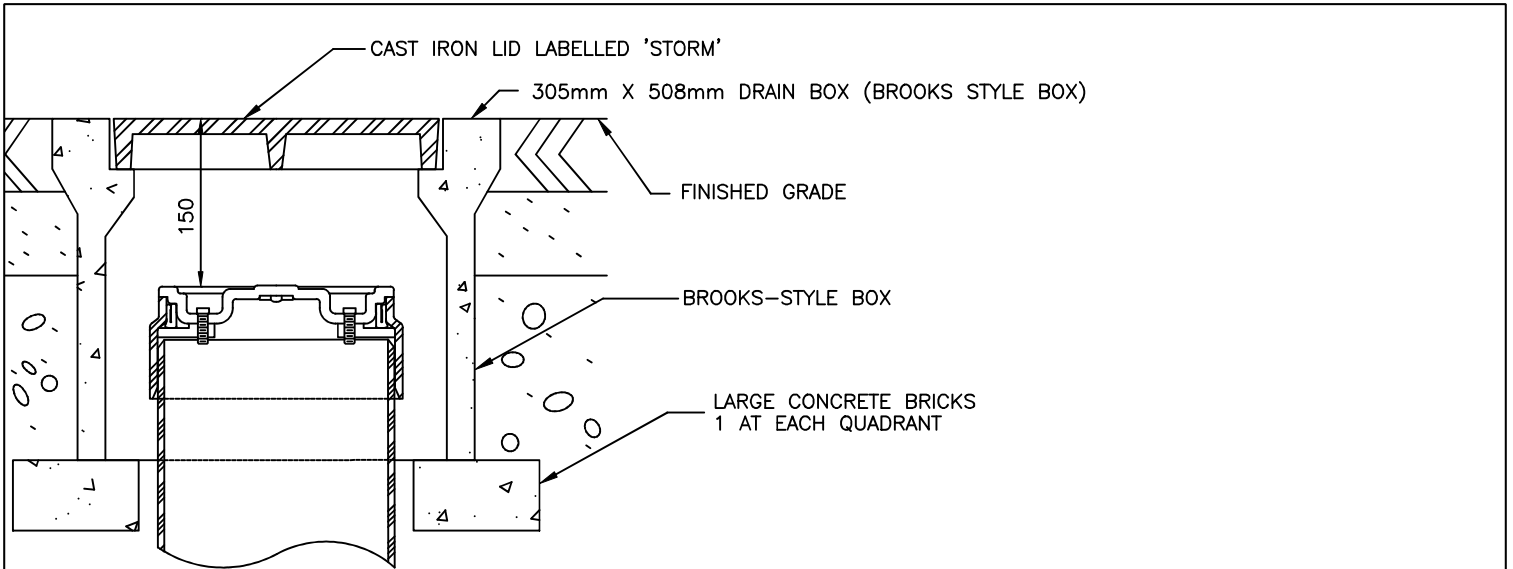

INSTALLATION WITH DRAIN BOX  
(BROOKS STYLE BOX)

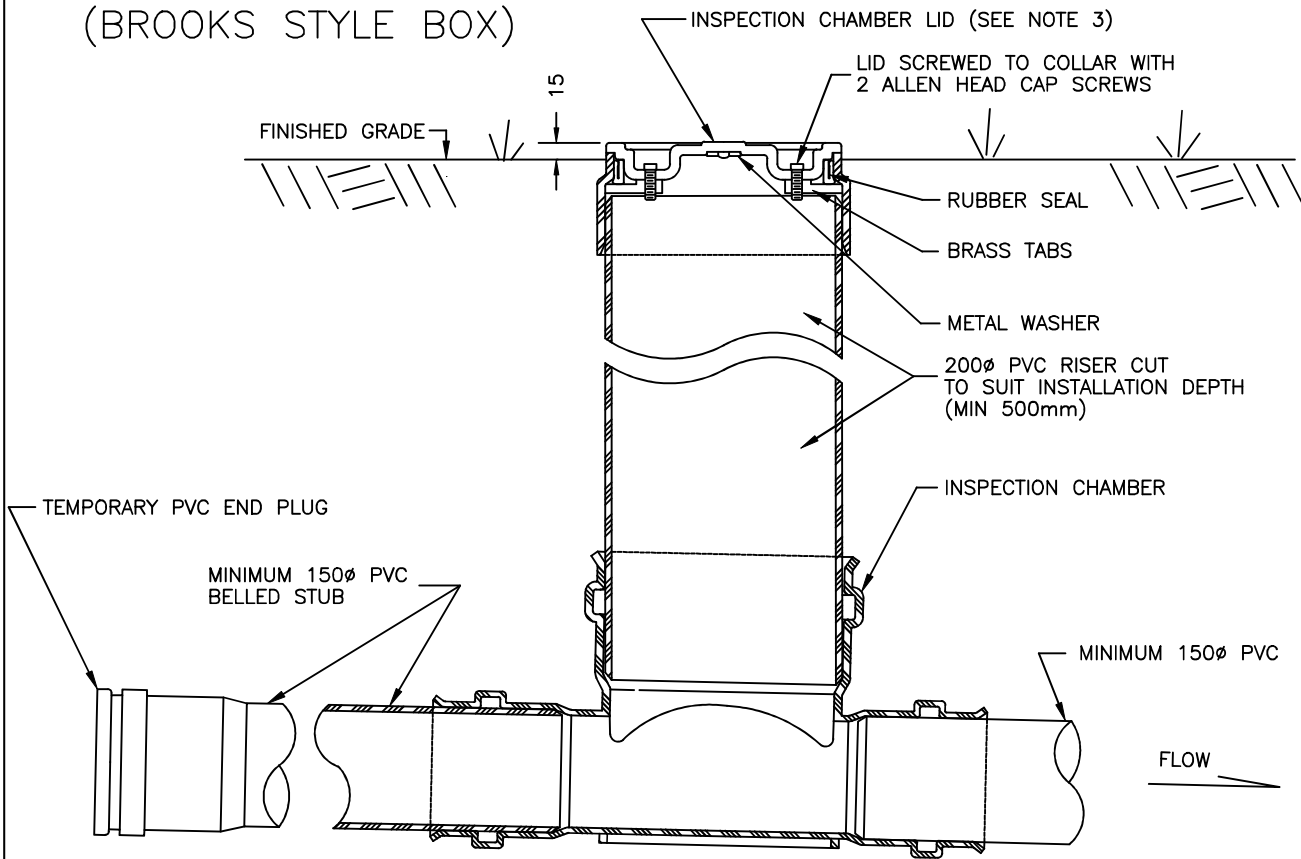

NOTES:

- 1) Paint upstream bell and end plug GREEN, for a minimum of 500mm below bell, at time of installation.
- 2) Refer to Specification Drawing No. ST-4 Typical 150mm Storm Connection.
- 3) Inspection chamber lid to be coloured red

**CITY OF SALMONARM**

No.	REVISION	Date
A	SDSB 4293 – ISSUED FOR APPROVAL	06/12/23

APPROVED



INSPECTION CHAMBER FOR  
STORM CONNECTION

SPECIFICATION  
DRAWING No.:

ST-6

SHORT DURATION RAINFALL INTENSITY – DURATION FREQUENCY DATA FOR SALMON ARM AIRPORT  
 BASED ON RECORDING RAIN GAUGE DATA FOR THE PERIOD 1964 – 2016

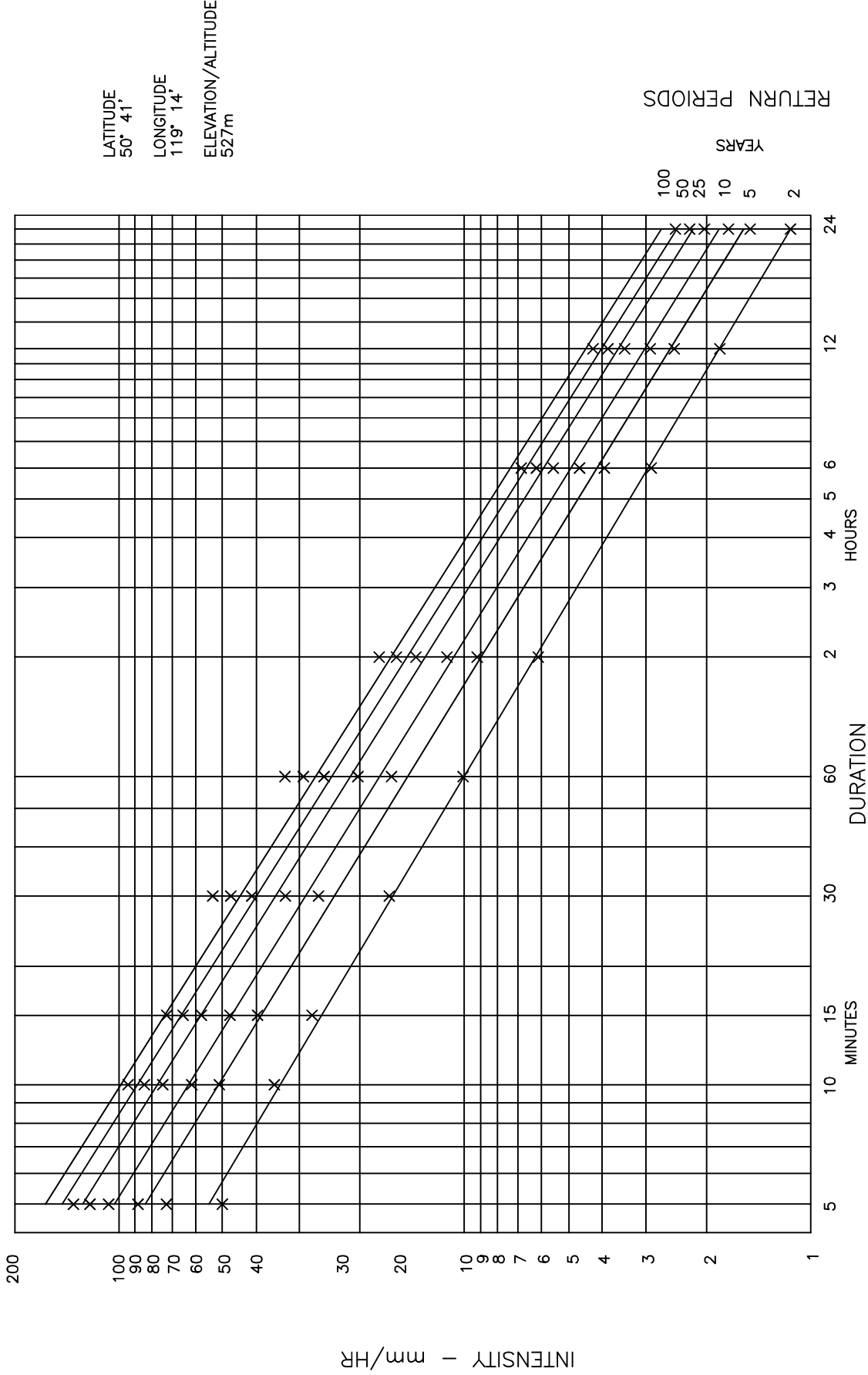

NOTES:

- 1) Reproduction from Environment Canada Rainfall Intensity-Duration Frequency Values 2016
- 2) Calculated flows shall be adjusted for Climate Change as per EGBC best practices.

No.	REVISION	Date
A	SDSB 4293 – ISSUED FOR APPROVAL	06/12/23

**CITY OF SALMON ARM**  
 Permit to Practice: 1001265



APPROVED

RAINFALL INTENSITY-DURATION DATA

SPECIFICATION  
 DRAWING No.:

ST-7

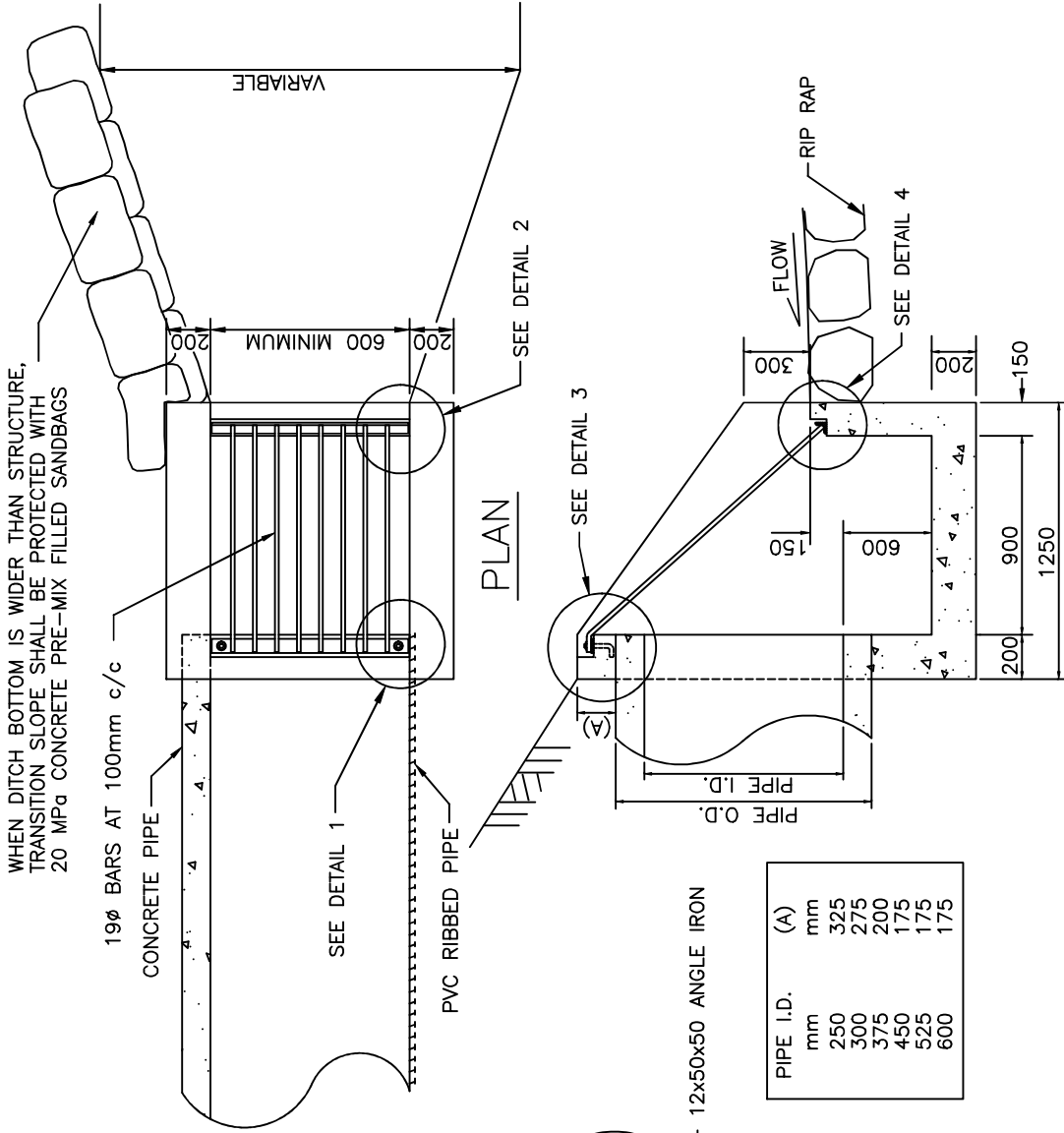

WHEN DITCH BOTTOM IS WIDER THAN STRUCTURE, TRANSITION SLOPE SHALL BE PROTECTED WITH 20 MPa CONCRETE PRE-MIX FILLED SANDBAGS

**SECTION**

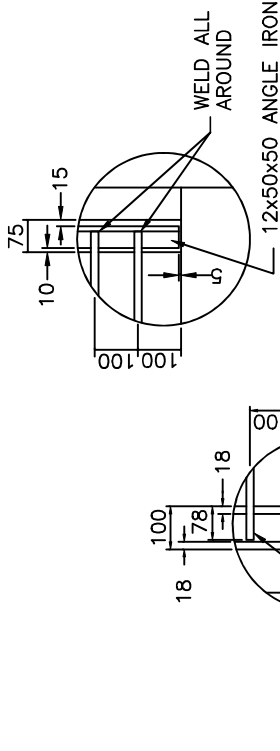

**DETAIL 1**

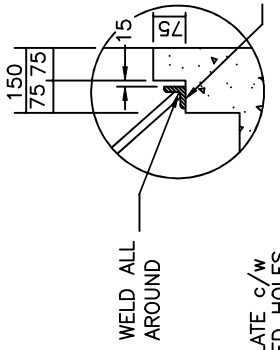

**DETAIL 2**

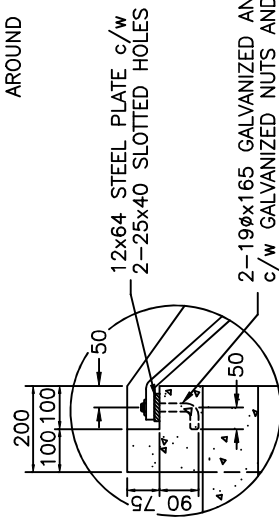

**DETAIL 3**



**DETAIL 4**

PIPE I.D.	(A)
mm	mm
250	325
300	275
375	200
450	175
525	175
600	175

**NOTES:**

- 1) All external edges to be chamfered to 13mm.
- 2) Sandbags to be of good condition and containing approximately 25Kg. of 20 MPa Concrete Pre-mix.
- 3) Trash Rack to be coated with Two Coats of Galvacon or Hot Dipped Galvanized.
- 4) Where storm is larger than 600Ø, Consulting Engineer will provide detailed design.

APPROVED



TYPICAL CAST IN PLACE INLET STRUCTURE (250Ø to 600Ø Storm Pipe)

No.	REVISION	Date
A	SDSB 4293 – ISSUED FOR APPROVAL	06/12/23

**CITY OF SALMON ARM**

SPECIFICATION DRAWING No.: ST-8

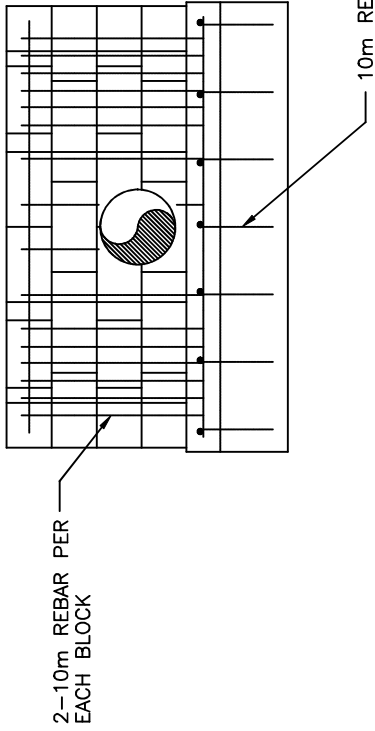

SECTION A-A

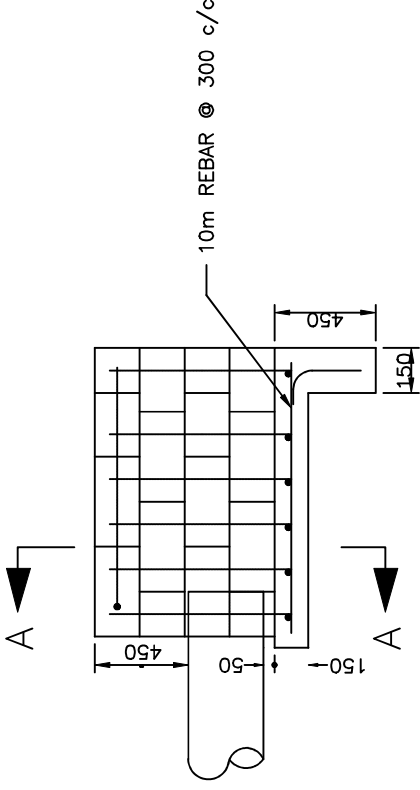

SECTION B-B

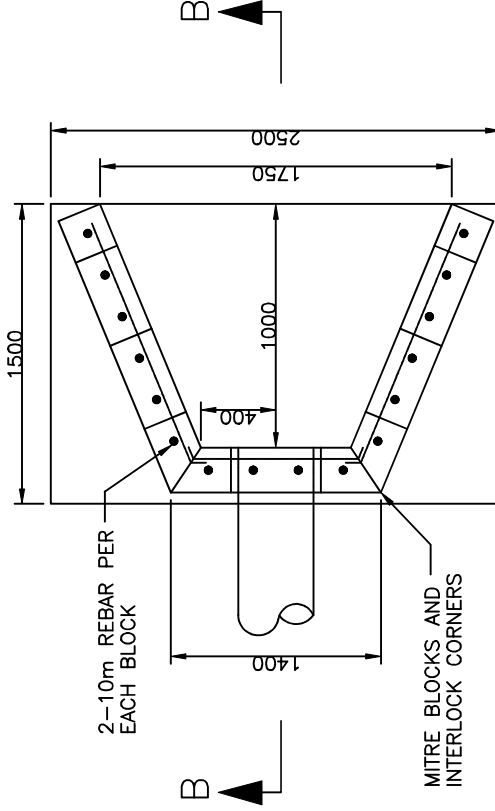

PLAN

NOTES:

- 1) Monolithic energy dissipating baffles may be required in Outlet Structures.
- 2) Residential or commercial driveway crossings ONLY.

No.	REVISION	Date
A	SDSB 4293 – ISSUED FOR APPROVAL	06/12/23

**CITY OF**  
**SALMON ARM**

Permit to Practice: 1001265



APPROVED

CONCRETE BLOCK INLET/OUTLET  
 STRUCTURE (250Ø to 600Ø Storm  
 Pipe)

SPECIFICATION  
 DRAWING No.:

ST-9

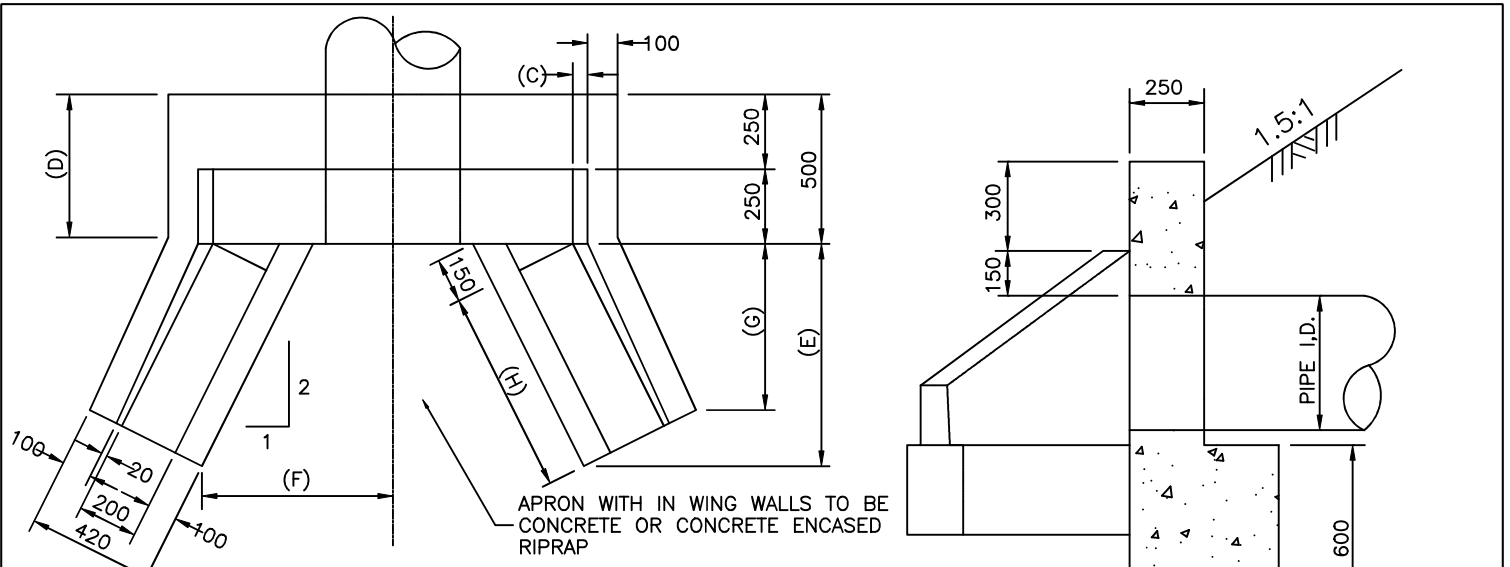

PLAN

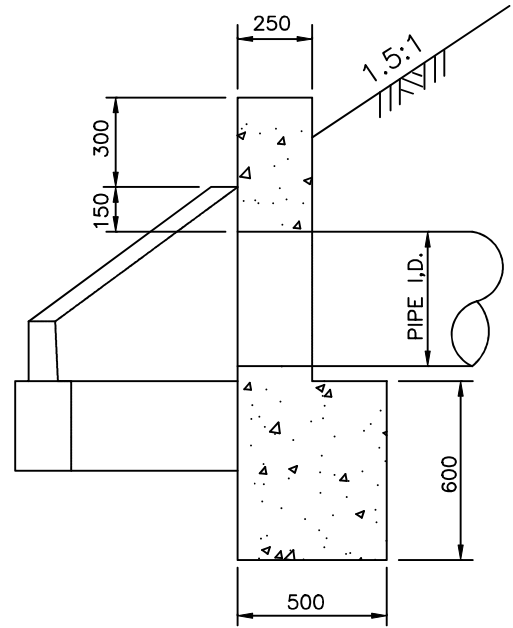

SECTION

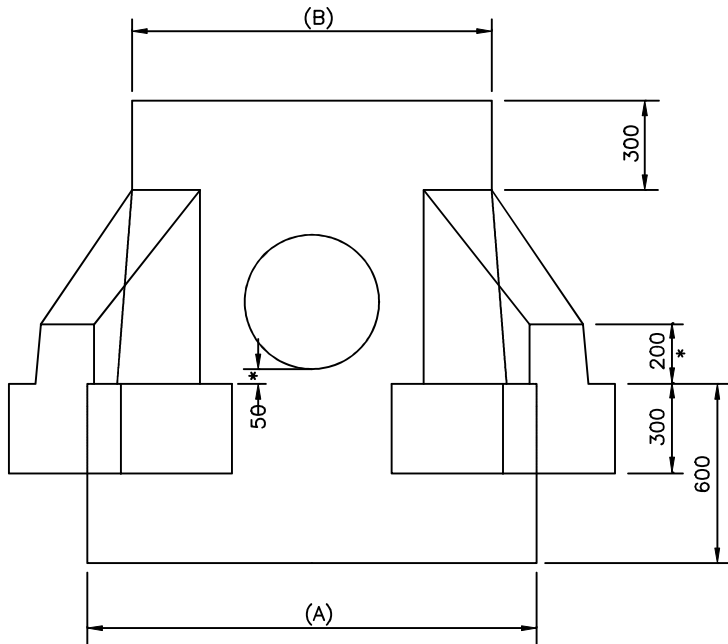

ELEVATION

\* INCREASE DIMENSION IF NECESSARY FOR GOOD FOUNDATION

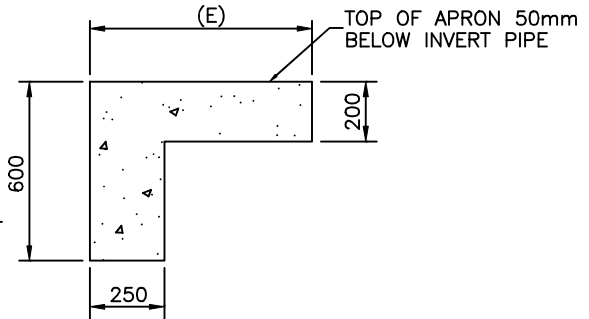

CONCRETE APRON

PIPE DIA.	A	B	C	D	E	F	G	H
250	1400	1120	40	470	750	540	560	690
300	1400	1120	40	470	750	565	560	690
375	1400	1120	40	470	750	600	560	690
450	1505	1205	50	470	750	645	560	690
600	1690	1360	65	470	980	835	790	945
750	1870	1520	75	460	1200	1025	1010	1190
900	2040	1660	90	460	1430	1210	1240	1450
1050	2215	1815	100	460	1660	1405	1470	1705

NOTES:

- 1) All external edges to be chamfered to 13mm.
- 2) Structure to be reinforced with 15M rebar at 300mm c/c each way. (Not Shown)
- 3) Refer to Dwg. ST-11 for Grillage.
- 4) Monolithic energy dissipating baffles may be required in Outlet Structures.

**CITY OF SALMON ARM**

No.	REVISION	Date
A	SDSB 4293 – ISSUED FOR APPROVAL	06/12/23

APPROVED



TYPICAL CONCRETE OUTLET STRUCTURE (250ø to 1050ø Storm Pipe)

SPECIFICATION DRAWING No.:

ST-10

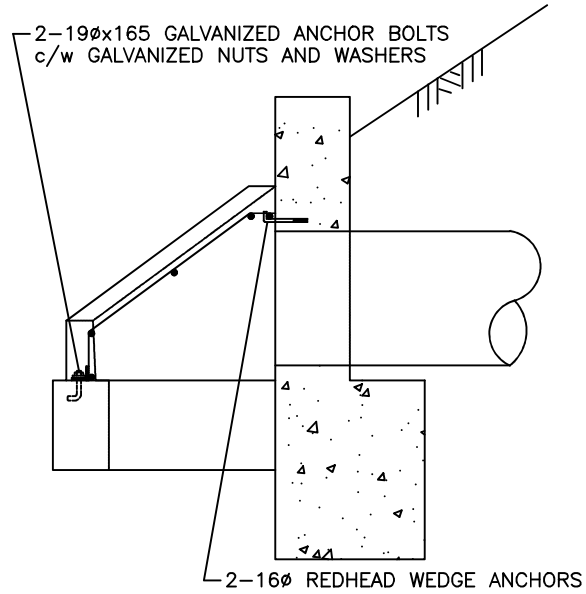
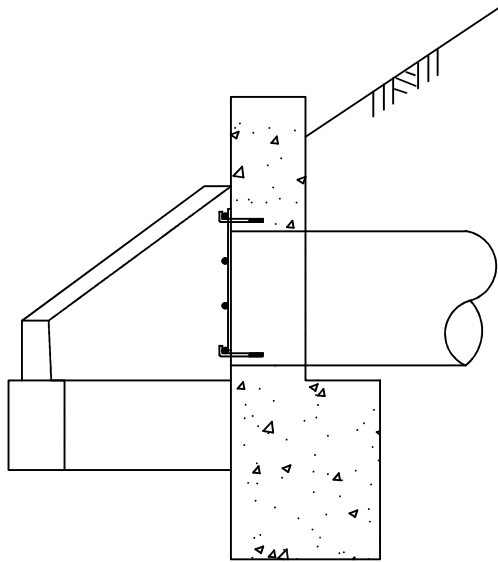

TRASH SCREEN FROM 15M REBAR WELDED  
AT ALL CONTACTS ON 150mm c/c AND  
FASTENED TO STRUCTURE WITH 4-16Ø  
REDHEAD WEDGE ANCHORS

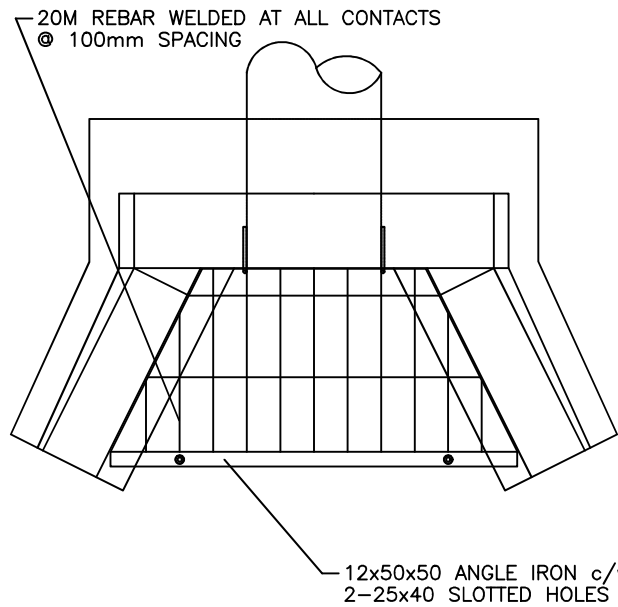
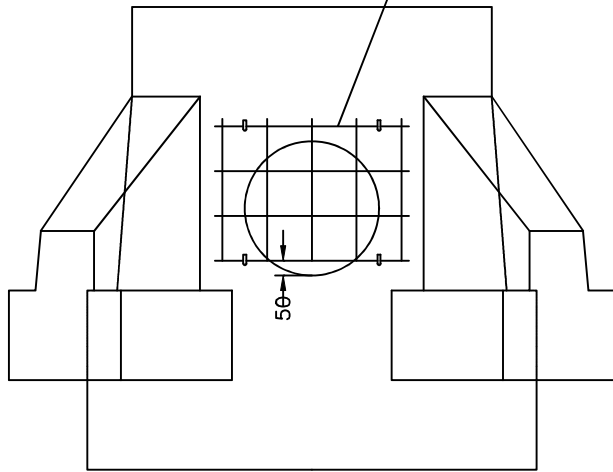

OUTLET GRILLAGE

INLET GRILLAGE

NOTES:

- 1) Grillage to be coated with Two Coats of Galvacon or Hot Dipped Galvanized.

**CITY OF  
SALMONARM**

No.	REVISION	Date
A	SDSB 4293 – ISSUED FOR APPROVAL	06/12/23

APPROVED



SAFETY GRILLAGE FOR  
INLET/OUTLET STRUCTURE

SPECIFICATION  
DRAWING No.:

ST-11

SUBGRADE DRAIN: 5m –  
100mm PVC SDR 28  
PERFORATED PIPE  
COMPLETE WITH 300mm  
X 300mm DRAIN ROCK  
WRAPPED IN FILTER  
CLOTH TIED INTO CB  
BARREL AND CAPPED AT  
ENDS. (TYP.)

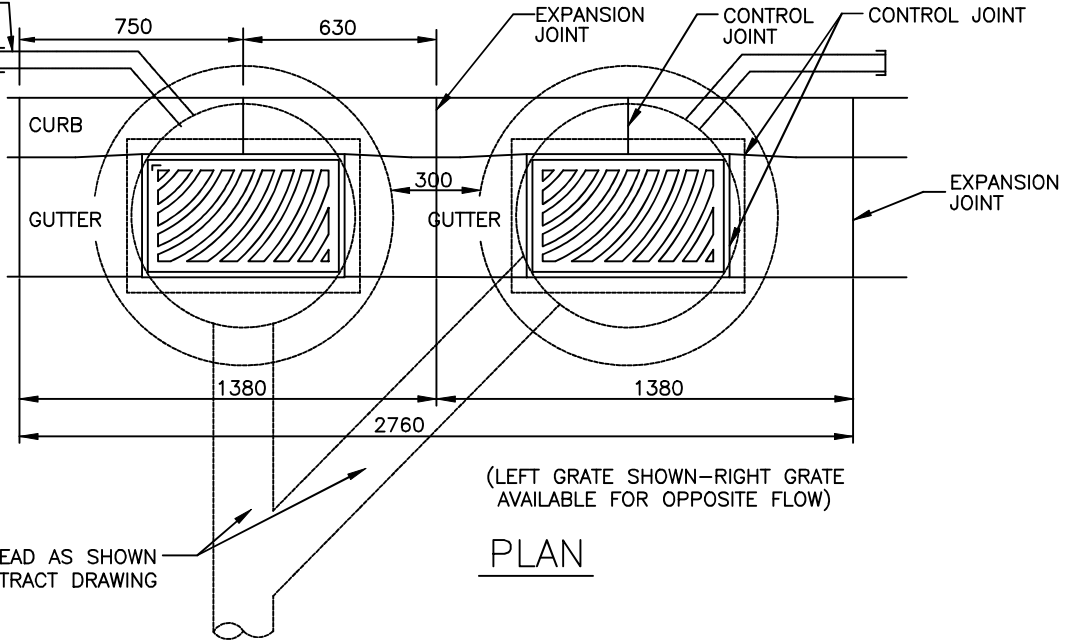
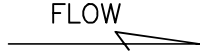

(LEFT GRATE SHOWN—RIGHT GRATE  
AVAILABLE FOR OPPOSITE FLOW)

PLAN

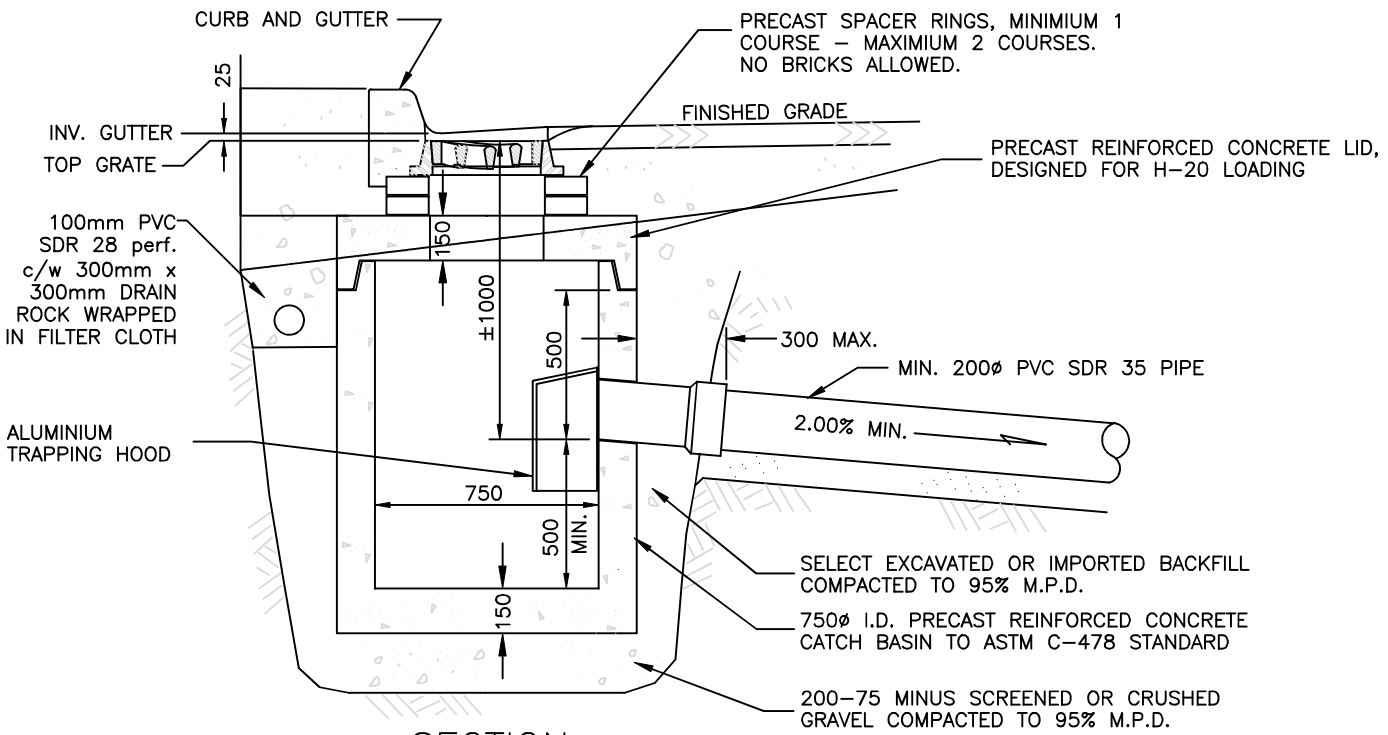

SECTION

NOTES:

- 1) Catch basin lid, precast spacer rings & any breaks made into catch basin sections shall be made water tight with approved mortar, sealants or gaskets inside and out.
- 2) All joints and spacer rings to have smooth mortar finish.
- 3) Outlet entry to be precored by supplier.
- 4) Frame & grate to be set at 25mm below finished gutter invert design grade.
- 5) Catch basins to have side inlet where road grade exceeds 5%.

**CITY OF**  
**SALMONARM**

No.	REVISION	Date
A	SDSB 4293 – ISSUED FOR APPROVAL	06/12/23

APPROVED



DOUBLE CATCH BASIN

SPECIFICATION  
DRAWING No.:

ST-12



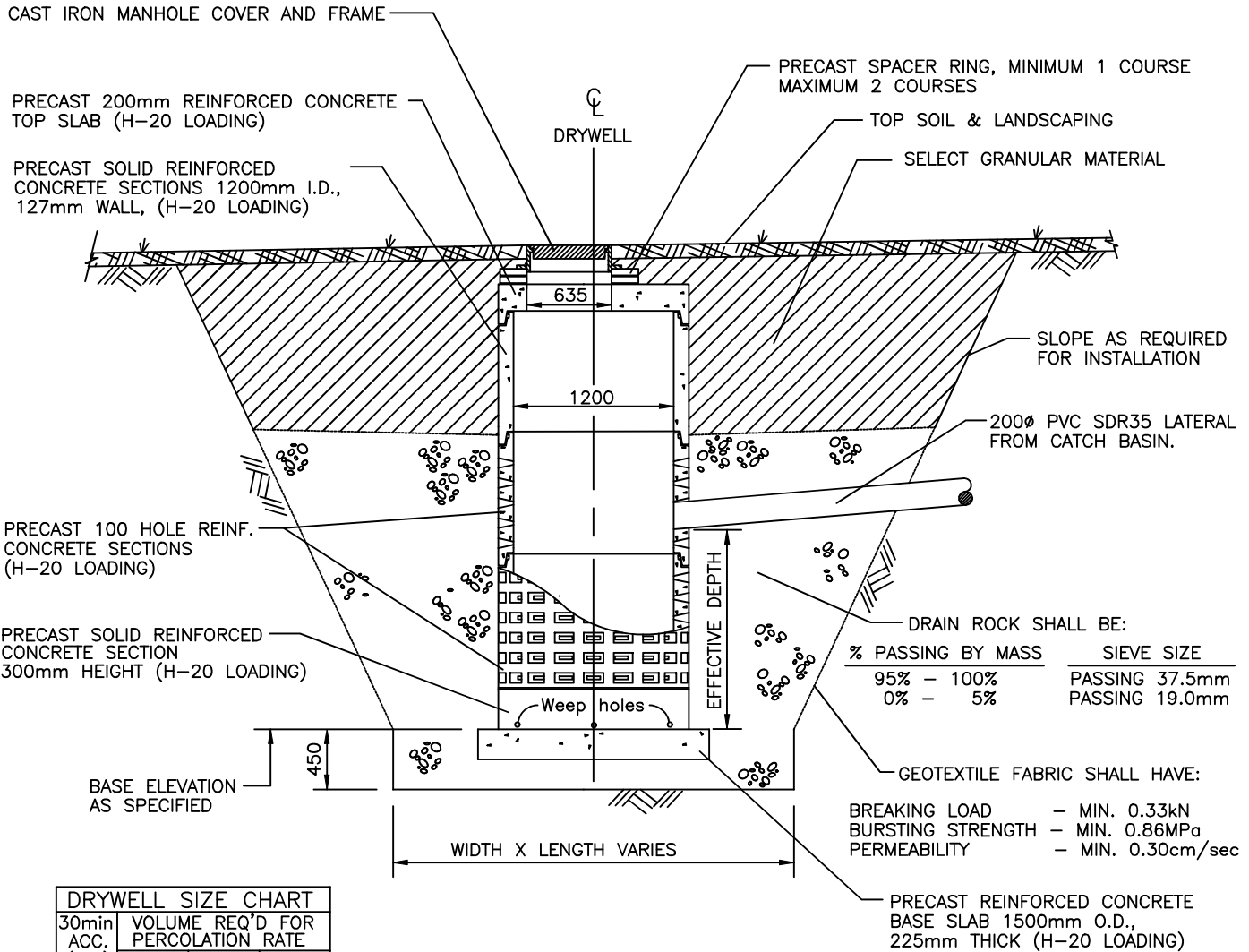

DRYWELL SIZE CHART			
30min ACC. (m <sup>3</sup> )	VOLUME REQ'D FOR PERCOLATION RATE		
	2min	5min	10min
100	172	213	230
200	373	441	469
300	583	673	708
400	794	912	953
500	1018	1141	1189

**NOTES:**

- 1) Precast manhole base may be used in place of cast-in-place slab.
- 2) Frame & cover to be set at 5mm below finished grade.
- 3) Size to be confirmed by a Consulting Engineer.
- 4) Design Engineer to calculate effective depth and dimensions of drain rock based on percolation data.

**CITY OF SALMON ARM**

No.	REVISION	Date
A	SDSB 4293 – ISSUED FOR APPROVAL	06/12/23

APPROVED



TYPICAL DRAINAGE DRYWELL

SPECIFICATION  
DRAWING No.:

ST-13

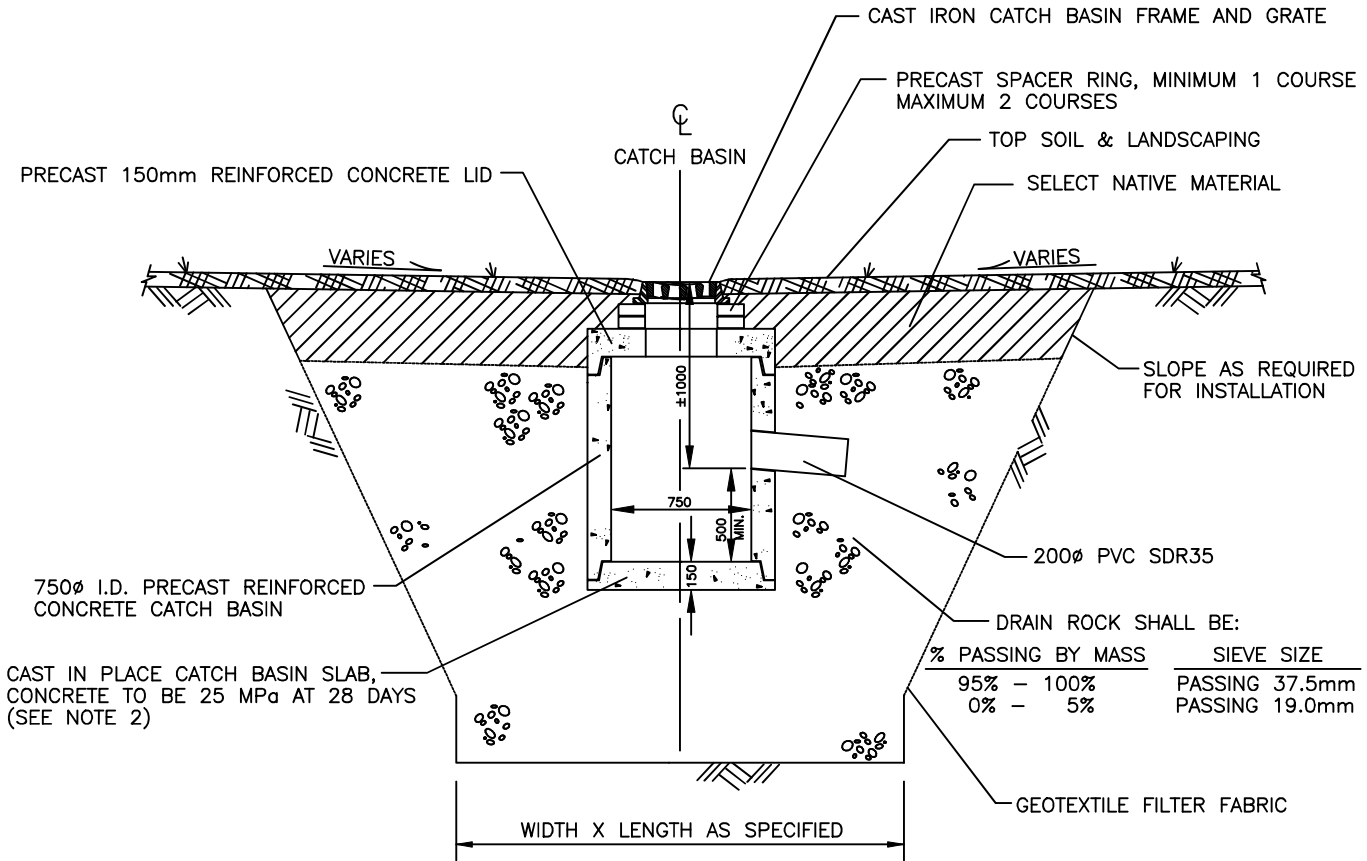

**NOTES:**

- 1) Catch basin sections, lid & any breaks made into catch basin sections shall be made water tight with approved mortar, sealants or gaskets inside and out.
- 2) Precast catch basin base may be used in place of cast-in-place slab.
- 3) Requires approval from the City Engineer.

**CITY OF SALMON ARM**

No.	REVISION	Date
A	SDSB 4293 – ISSUED FOR APPROVAL	06/12/23

APPROVED



TYPICAL CATCH BASIN DRYWELL

SPECIFICATION  
DRAWING No.:

ST-14

STORM SEWER DESIGN SHEET  
RATIONAL FORMULA

SHEET \_\_\_\_\_ OF \_\_\_\_\_  
JOB NO.: \_\_\_\_\_  
DATE: \_\_\_\_\_

PROJECT \_\_\_\_\_ DESIGNED BY: \_\_\_\_\_  
STORM RETURN PERIOD \_\_\_\_\_ YEARS CHECKED BY: \_\_\_\_\_

DWG NO.	STREET OR LINE	FROM TO AREA	%AREA COEF. R	EFFECTIVE AREA		TIME OF CONCENTRATION		RAINFALL INTENSITY (minutes)	DESIGN FLOW $Q$ $m^3/s$	CAP. $m^3/s$	n	SLOPE	SIZE mm	VELOCITY $m^3/s$	PIPE LENGTH m	SLOPE	OTHER	TOTAL	UPSTREAM		DOWNSTREAM			
				%AREA * R INCR./TOTAL	MINUTES TOTAL	DROP	GROUND INV.											GROUND INV.	GROUND INV.	GROUND INV.				

APPROVED



STORM SEWER DESIGN SHEET

---

**CITY OF SALMON ARM**

Permit to Practice: 1001265

SPECIFICATION  
DRAWING No.:

ST-15

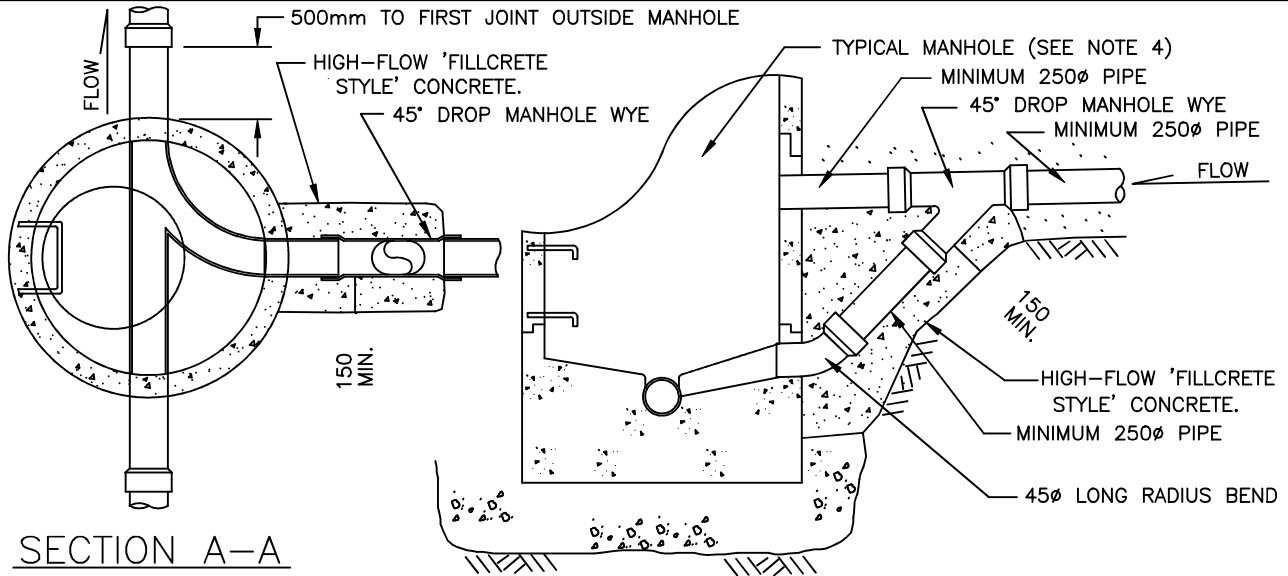

DROP LESS THAN 1500mm

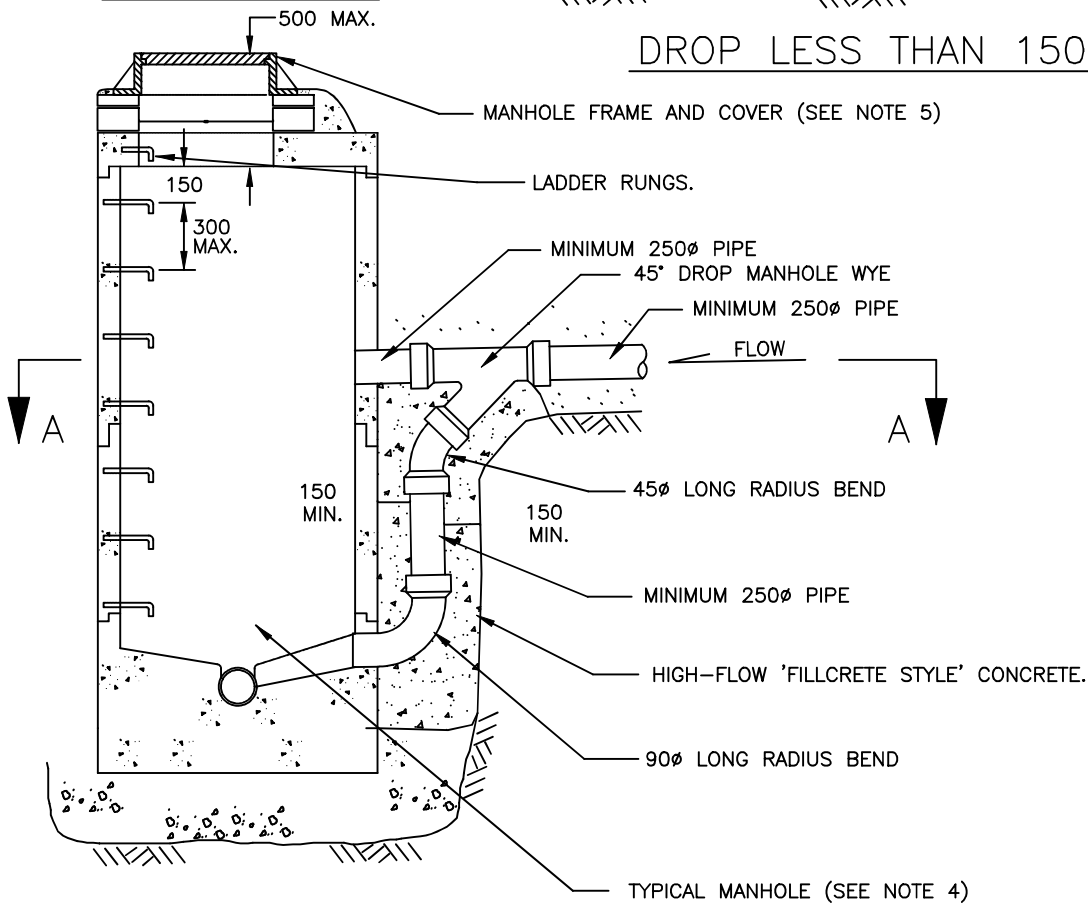

DROP GREATER THAN 1500mm

NOTES:

- 1) Inside ramps shall be utilized where the elevation of the invert is the same or below the crown of the through pipe (Refer to Specification Drawing ST-2).
- 2) All joints to have smooth mortar finish.

- 3) Encasement Concrete strength to be high-flow 'fillcrete style' concrete.
- 4) Refer to Specification Drawing No. ST-2, Typical 1050mm Storm Manhole.
- 5) Refer to Specification Drawing No. ST-3, H-20 Manhole Frame & Cover.
- 6) Inside drop to be approved by the City Engineer.

<b>CITY OF SALMON ARM</b>		
No.	REVISION	Date
A	SDSB 4293 – ISSUED FOR APPROVAL	06/12/23

APPROVED

TYPICAL 1050mm STORM DROP MANHOLE

SPECIFICATION DRAWING No.: ST-16

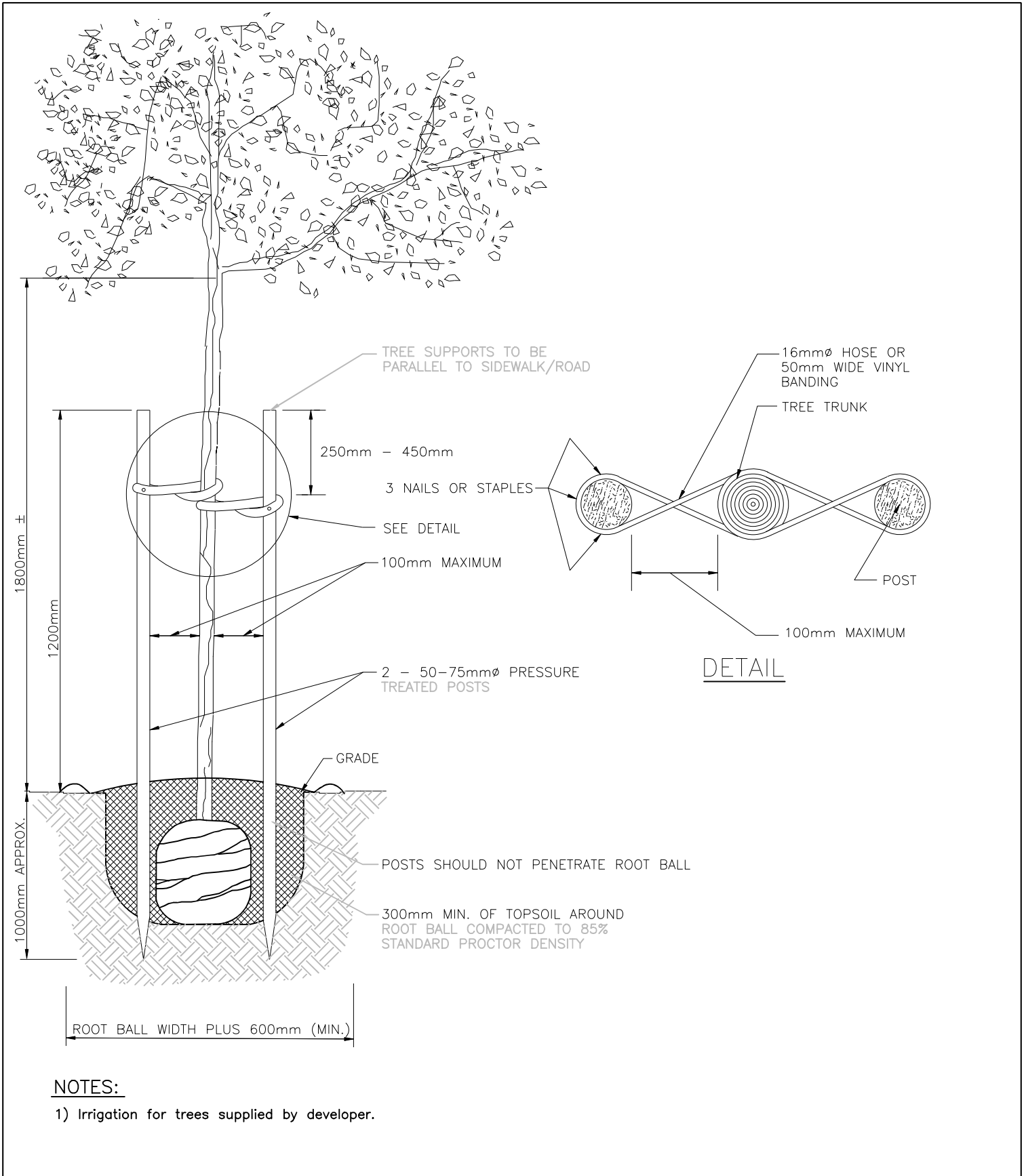

<b>CITY OF SALMON ARM</b>		
No.	REVISION	Date
A	SDSB 4293 – ISSUED FOR APPROVAL	06/12/23

APPROVED

TYPICAL DOUBLE TREE STAKES  
(for trees over 2m high)

SPECIFICATION  
DRAWING No.: TRE-1

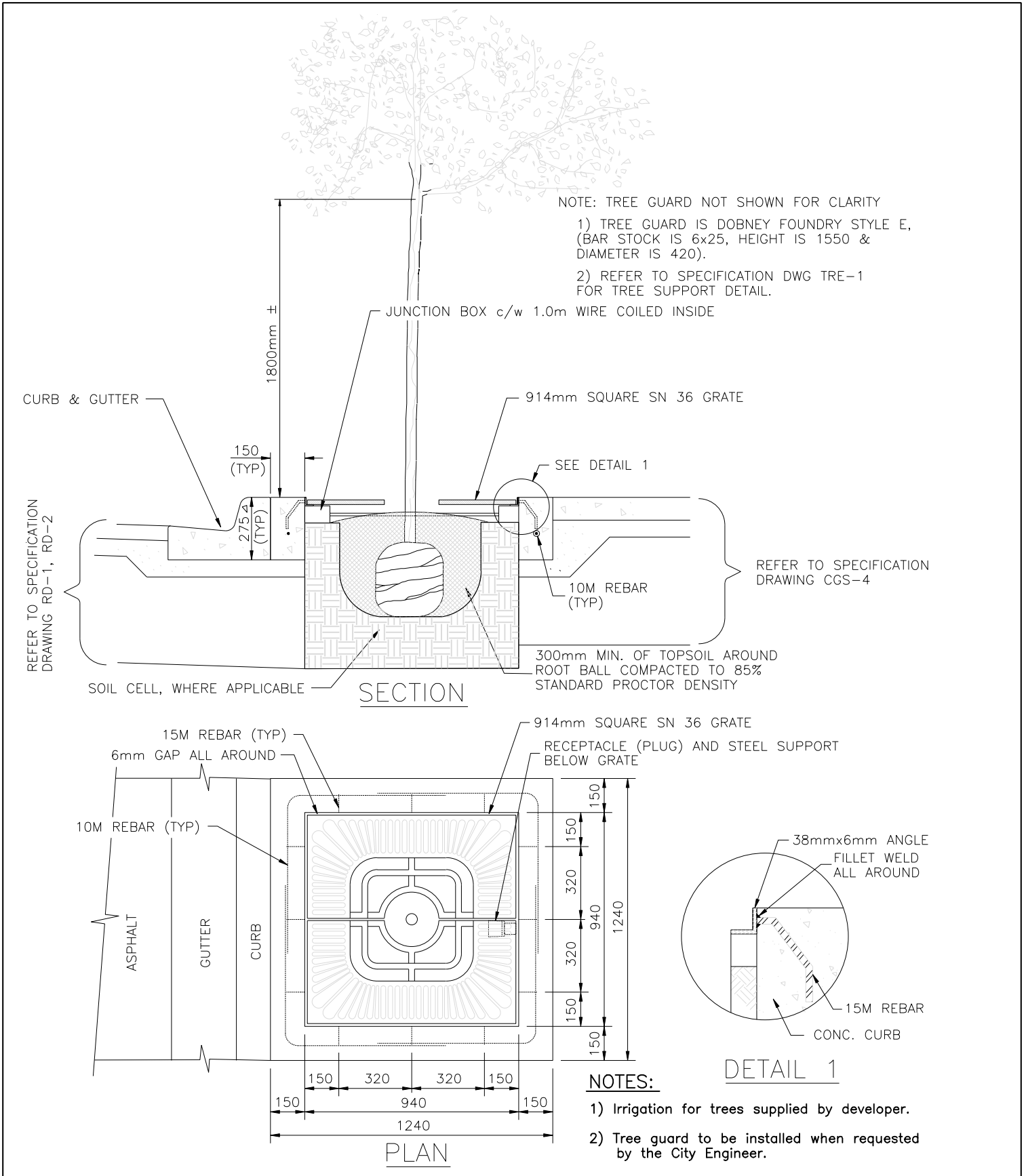

<b>CITY OF SALMONARM</b>		
No.	REVISION	Date
A	SDSB 4293 – ISSUED FOR APPROVAL	06/12/23

APPROVED

TYPICAL TREE  
(with Grate Guard and Receptacle)

SPECIFICATION  
DRAWING No.:

TRE-2

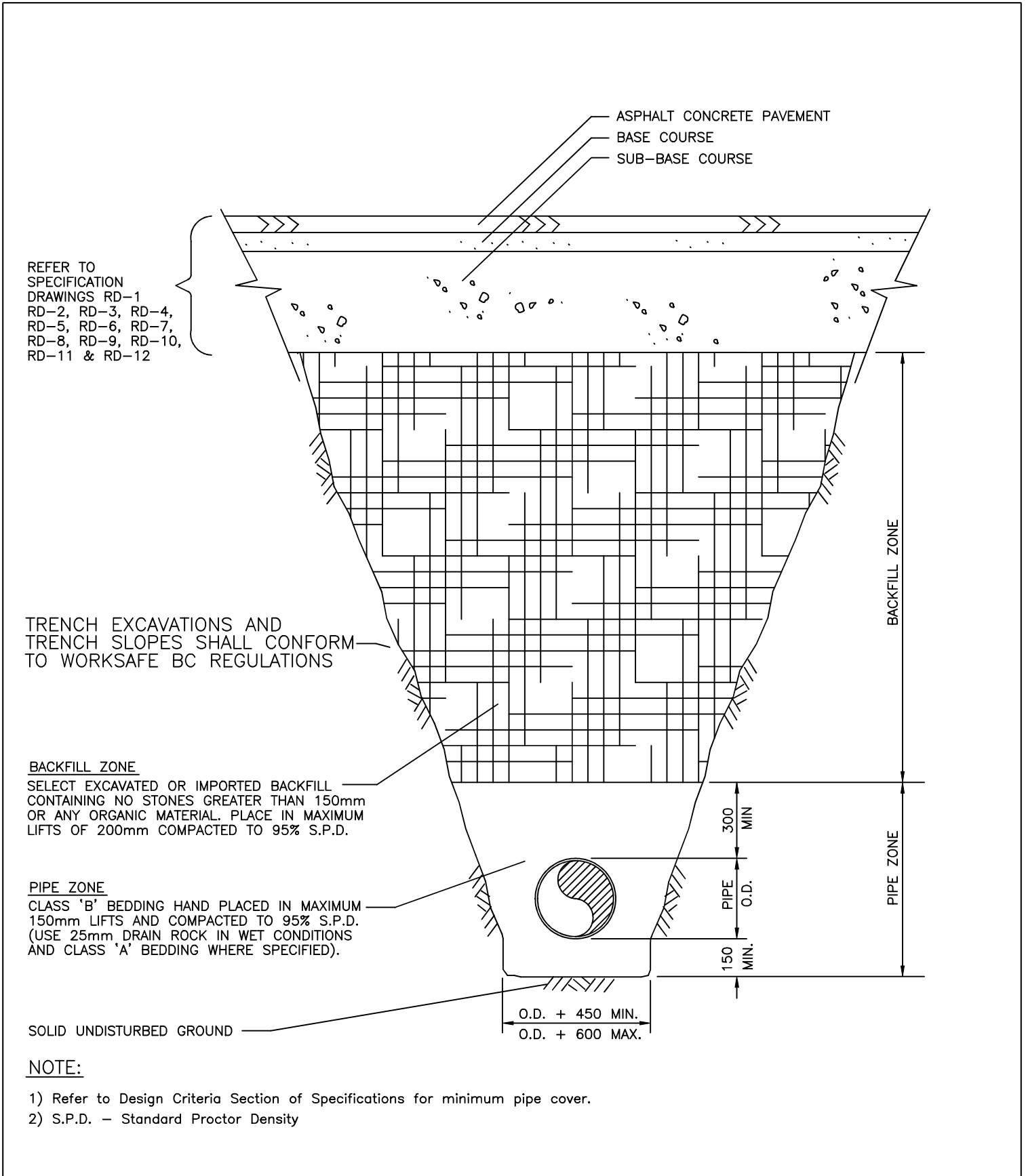

<b>CITY OF SALMON ARM</b>		
No.	REVISION	Date
A	SDSB 4293 – ISSUED FOR APPROVAL	06/12/23

APPROVED

TYPICAL UTILITY TRENCH IN ROADWAY

SPECIFICATION DRAWING No.: UT-1

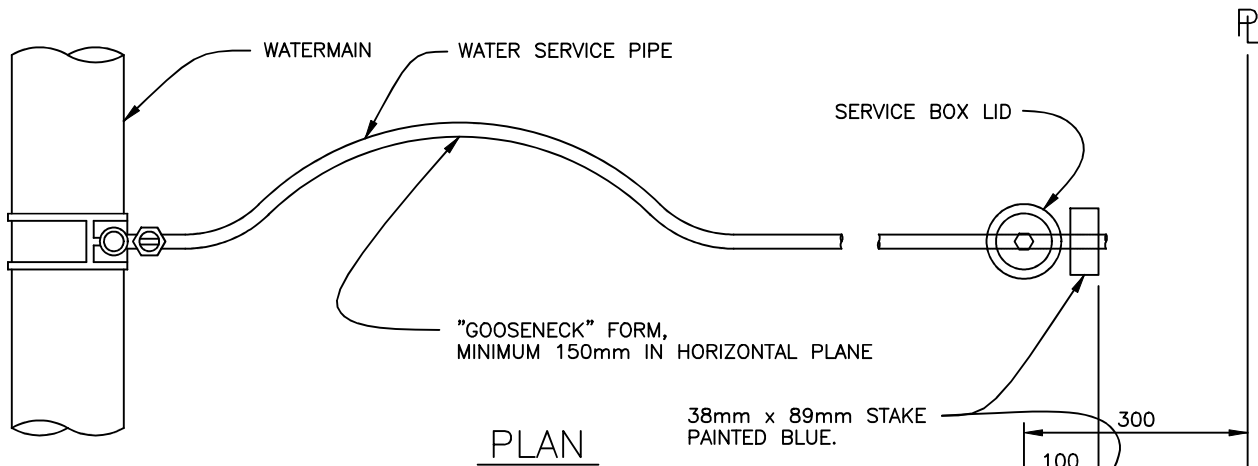

**NOTES:**

- 1) Service connections at watermain to be minimum 1.0m apart.
- 2) Services to run perpendicular from watermain to centre of lot.
- 3) Refer to Specification Drawing No. UT-1 & UT-2 for Typical Utility Trench.
- 4) Stainless Steel Stinger to be ±900mm Below finished Grade.
- 5) Tracer wire shall be installed on all services from corporation stop, day-lighting at top of curbstop
- 6) When curb-stop installed in driveway, place within a Brooks Box (or approved equivalent)

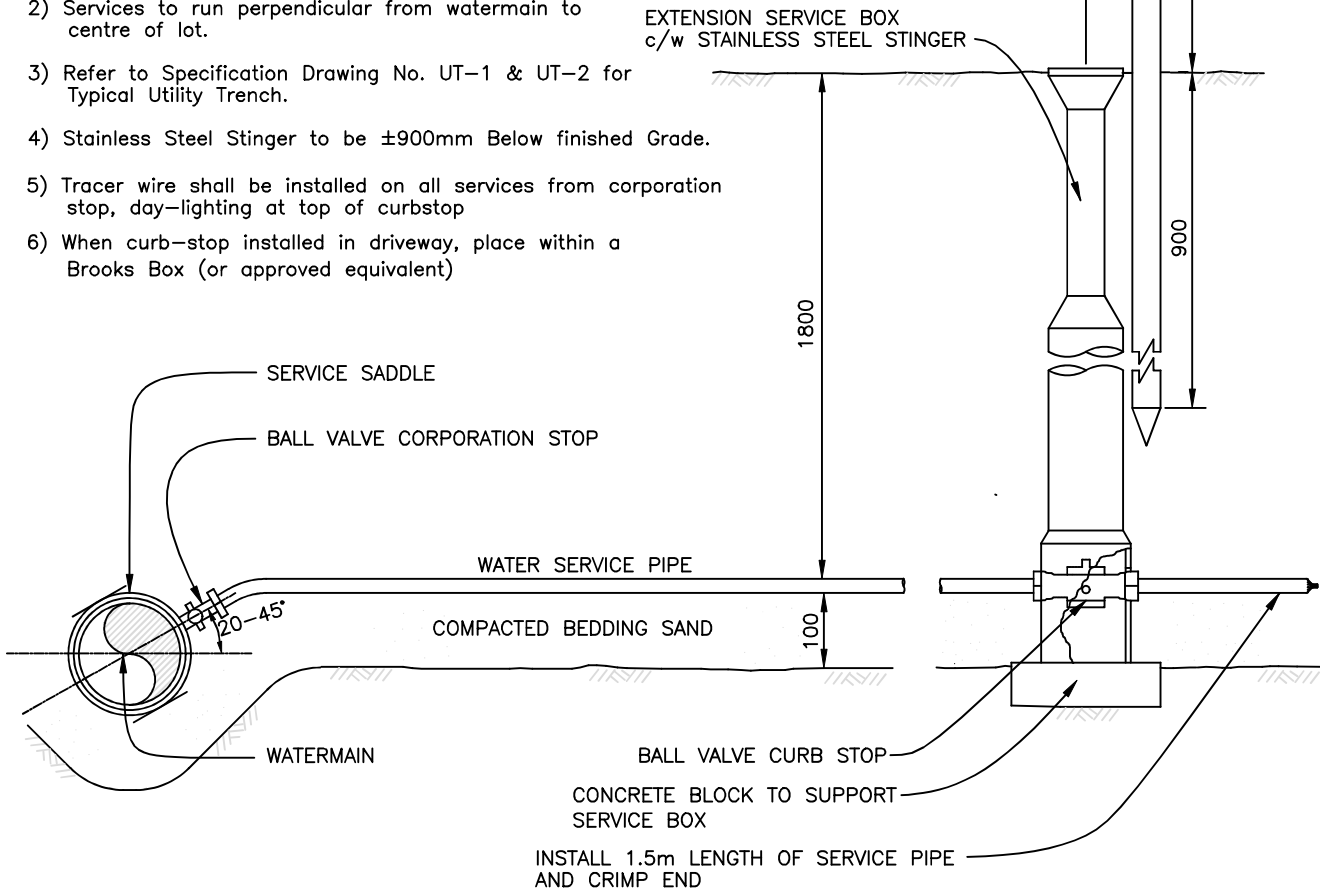

ELEVATION

**CITY OF SALMON ARM**

No.	REVISION	Date
A	SDSB 4293 – ISSUED FOR APPROVAL	06/12/23

APPROVED



TYPICAL UTILITY TRENCH IN BOULEVARD

SPECIFICATION DRAWING No.:

UT-2



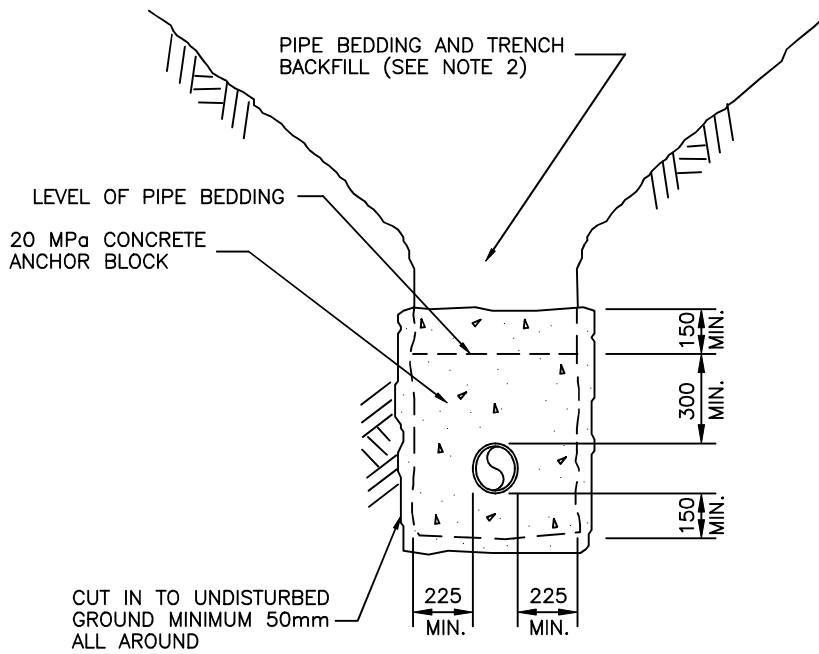
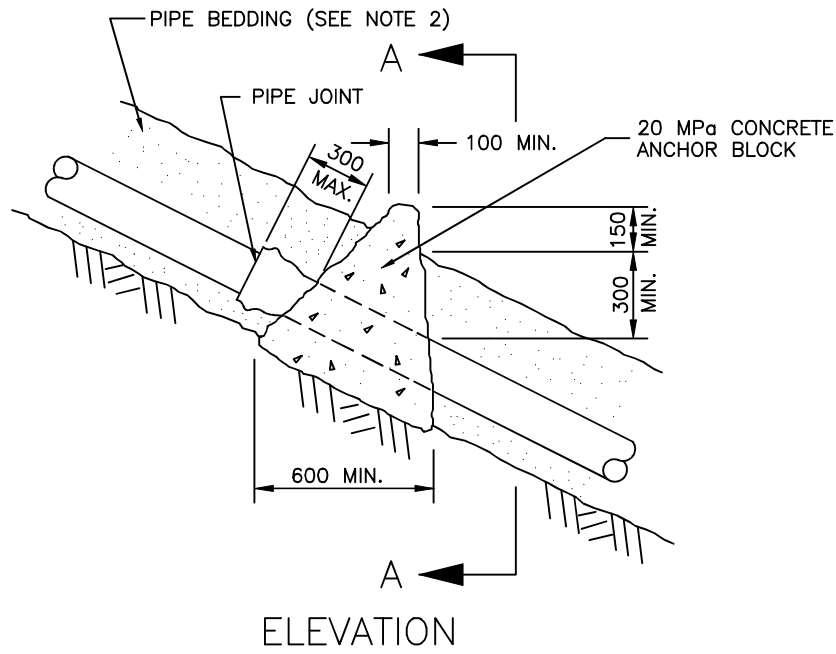

**NOTE:**

- 1) The requirement for, location of, and number of, Anchor Blocks and/or Mechanical Pipe Restraints shall be site specific.
- 2) Refer to Specification Drawing No. UT-1, UT-2 Typical Utility Trench in Roadway, Typical Utility Trench in Boulevard.
- 3) Concrete shall be kept clear of bells.
- 4) Concrete strength to be 20 MPa at 28 days.

**CITY OF SALMON ARM**

No.	REVISION	Date
A	SDSB 4293 – ISSUED FOR APPROVAL	06/12/23

APPROVED



ANCHOR BLOCKS

SPECIFICATION  
DRAWING No.:

UT-3

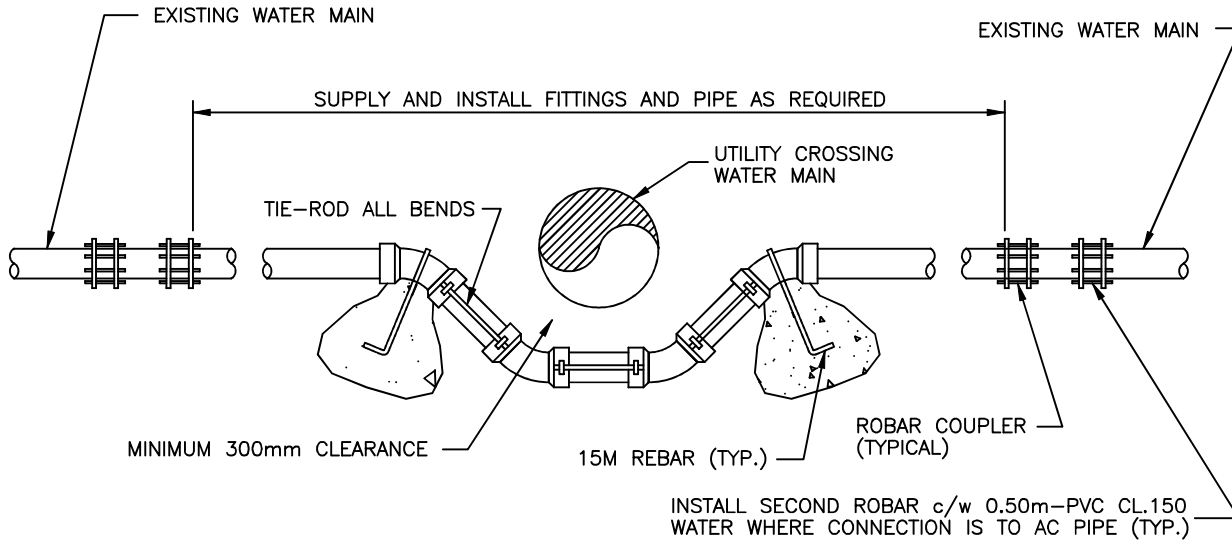

TYPICAL UTILITY CROSSING WATER MAIN

SCALE

N.T.S.

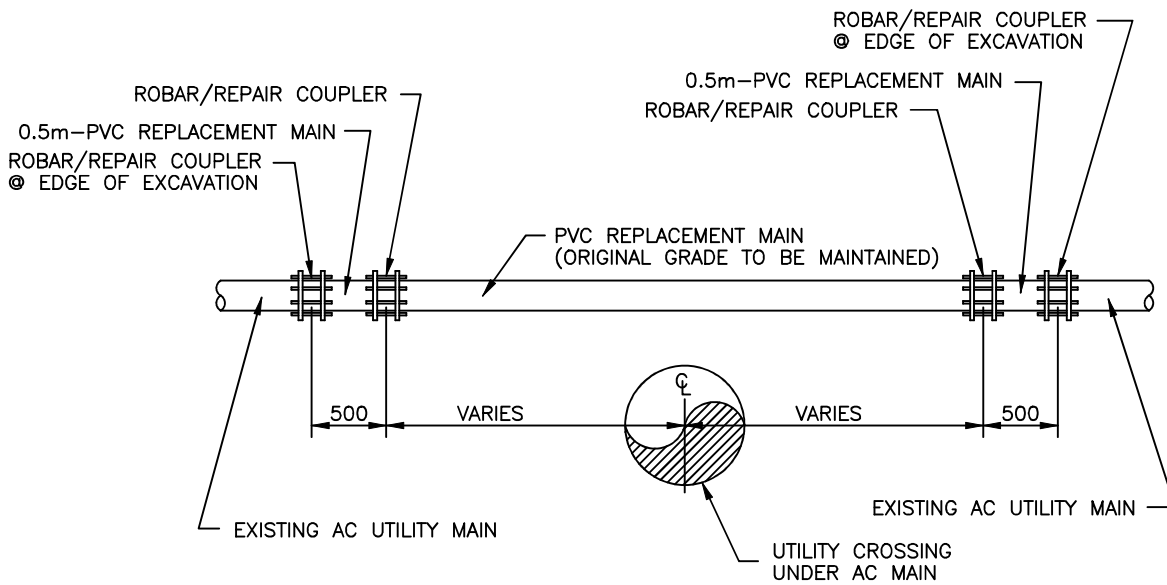

TYPICAL UTILITY CROSSING UNDER AC MAIN

SCALE

N.T.S.

NOTE:

1) 3 Robars may be used when approved by the City Engineer.

**CITY OF SALMON ARM**

No.	REVISION	Date
A	SDSB 4293 – ISSUED FOR APPROVAL	06/12/23

APPROVED



UTILITY MAIN RELOCATION DETAILS

SPECIFICATION  
DRAWING No.:

UT-4

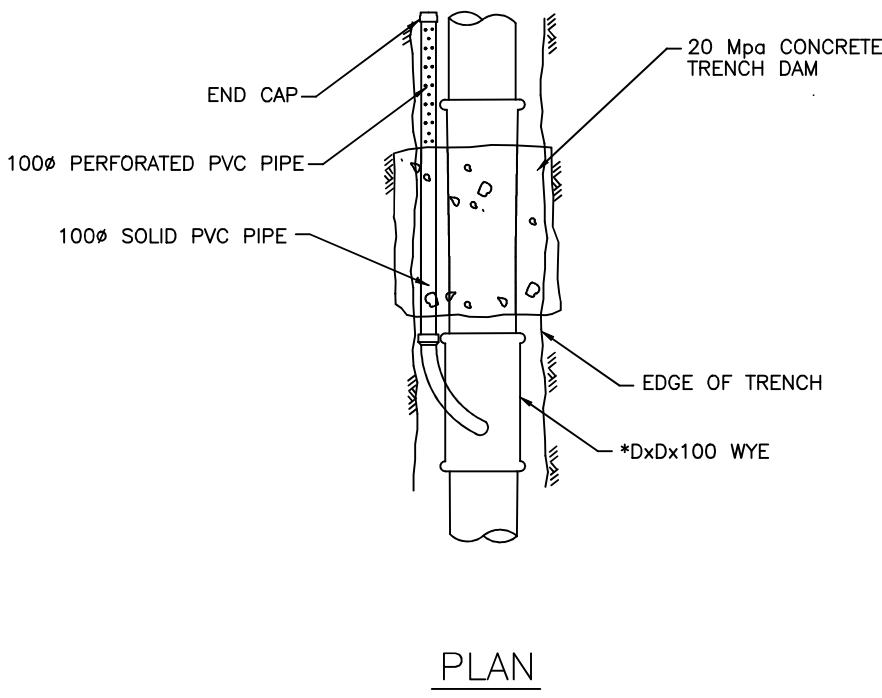
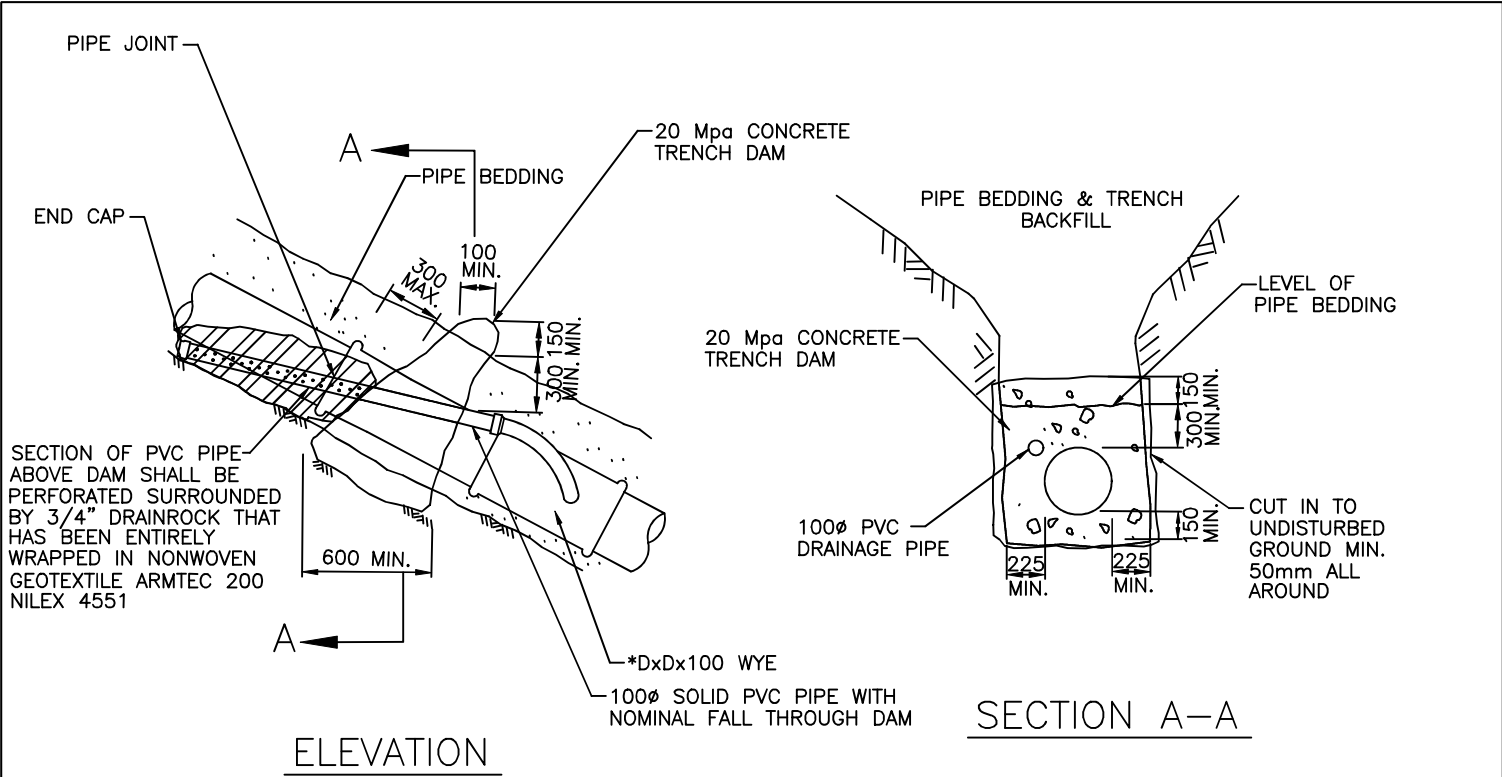

NOTE:

- 1) Concrete is to be kept clear of all bells.
- 2) Concrete strength to be 20 MPa at 28 days.

**CITY OF SALMONARM**

No.	REVISION	Date
A	SDSB 4293 – ISSUED FOR APPROVAL	06/12/23

APPROVED



TRENCH DAM DETAILS

SPECIFICATION  
DRAWING No.:

UT-5

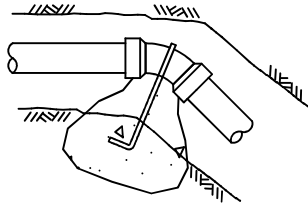

VERTICAL BEND

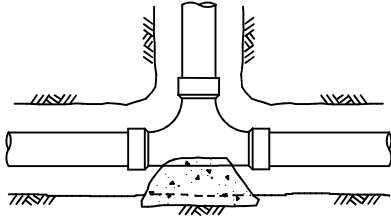

TEE

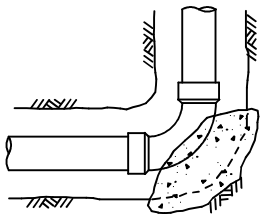

BEND

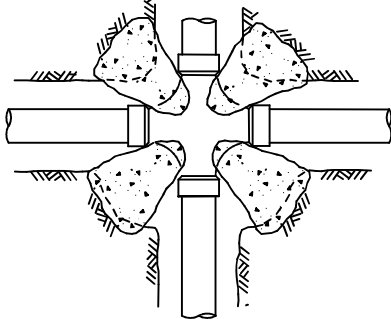

CROSS

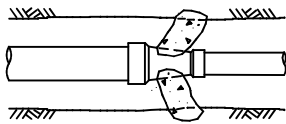

REDUCER

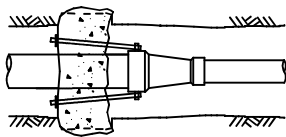

REDUCER

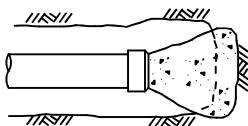

END CAP

TABLE I – Approx. thrust in kN at 1725 kPa water pressure

FITTING SIZE	TEES & DEAD ENDS	BENDS			
		90°	45°	22.5°	11.25°
100mm Ø	20.58	28.93	15.80	7.90	3.95
150mm Ø	42.25	60.05	32.25	16.13	8.08
200mm Ø	72.28	103.43	55.60	27.80	13.90
250mm Ø	120.65	154.58	83.95	41.98	21.00
300mm Ø	154.58	219.08	120.10	60.05	30.03

TABLE II – Approximate bearing loads for typical soils\*

SOIL TYPE	LOAD kPa(kN/m <sup>2</sup> )
MUCK, PEAT, ETC.	0.00
SOFT CLAY	47.88
SAND	95.76
SAND & GRAVEL	143.64
SAND & GRAVEL CEMENTED WITH CLAY	191.52
HARD SHALE	478.80

\*Approximate bearing loads for typical soils are presented in Table II, however, the Owner's Consulting Engineer is responsible for determining the safe bearing load for the soil and the design for each thrust block.

THRUST BLOCK CALCULATION

$$\frac{\text{Thrust (Table I)}}{\text{Bearing Load (Table II)}} = \text{Thrust Area (m}^2\text{)}$$

NOTES:

- 1) Thrust blocks shall be designed for minimum 1725 kPa water pressure.
- 2) Thrust Blocks to extend into undisturbed soil.
- 3) 6 mil Poly to be placed over fittings to prevent bonding with concrete.
- 4) Concrete shall be kept clear of bells.
- 5) Concrete strength to be 20 MPa at 28 days.
- 6) Engineered joint restraint system will be an acceptable alternative to thrust blocks.
- 7) Vertical bends require individual design.
- 8) Thrust Block on 5° Bends in accordance to the manufacturers specifications.
- 9) Precast thrust blocks acceptable with approvals from City Engineer

<b>CITY OF SALMON ARM</b>		
No.	REVISION	Date
A	SDSB 4293 – ISSUED FOR APPROVAL	06/12/23

APPROVED

THRUST BLOCK DETAILS

---

SPECIFICATION  
DRAWING No.: W-1

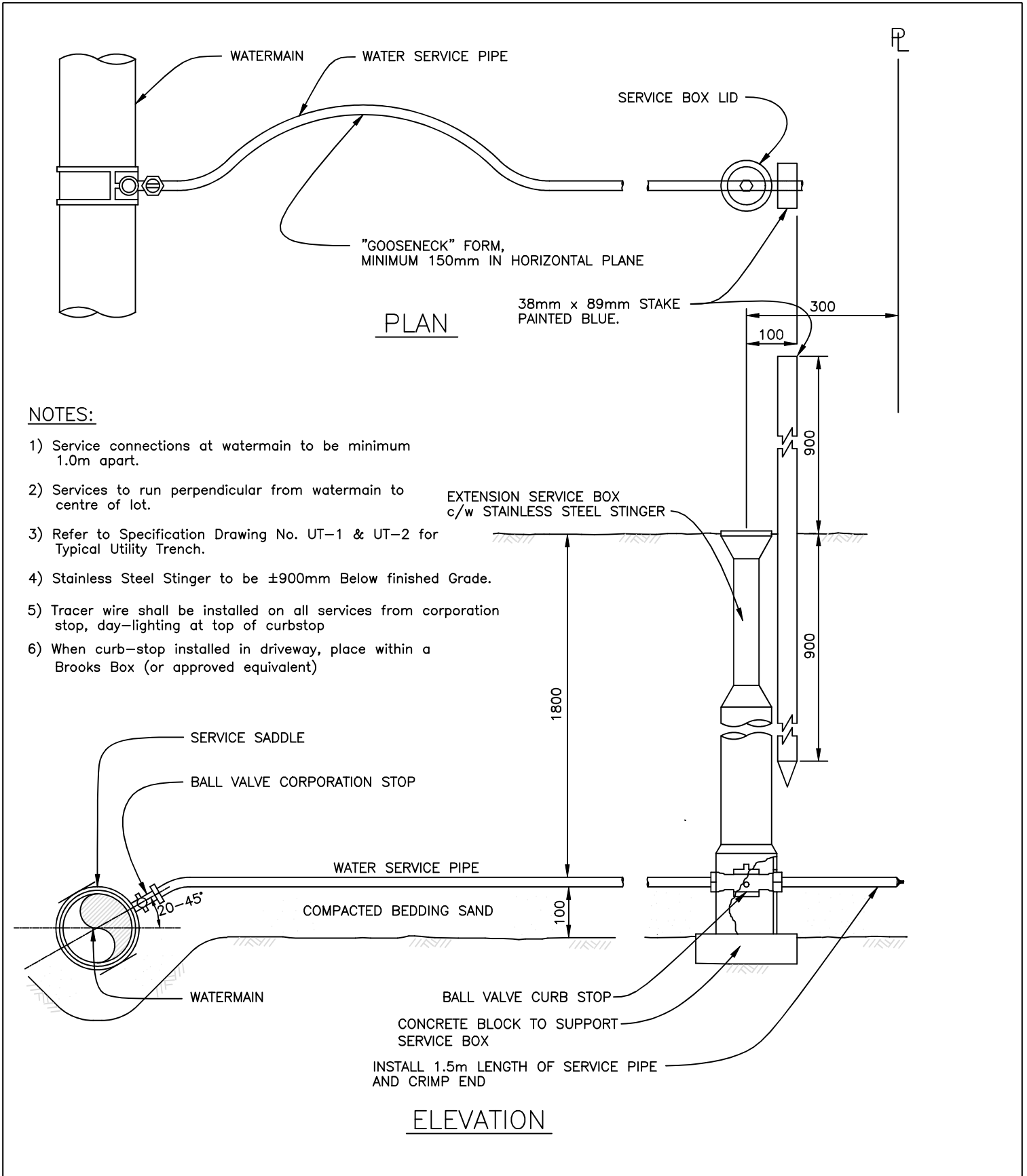

<b>CITY OF SALMON ARM</b>		
No.	REVISION	Date
A	SDSB 4293 – ISSUED FOR APPROVAL	06/12/23

APPROVED

TYPICAL WATER SERVICE CONNECTION

SPECIFICATION DRAWING No.:

W-2

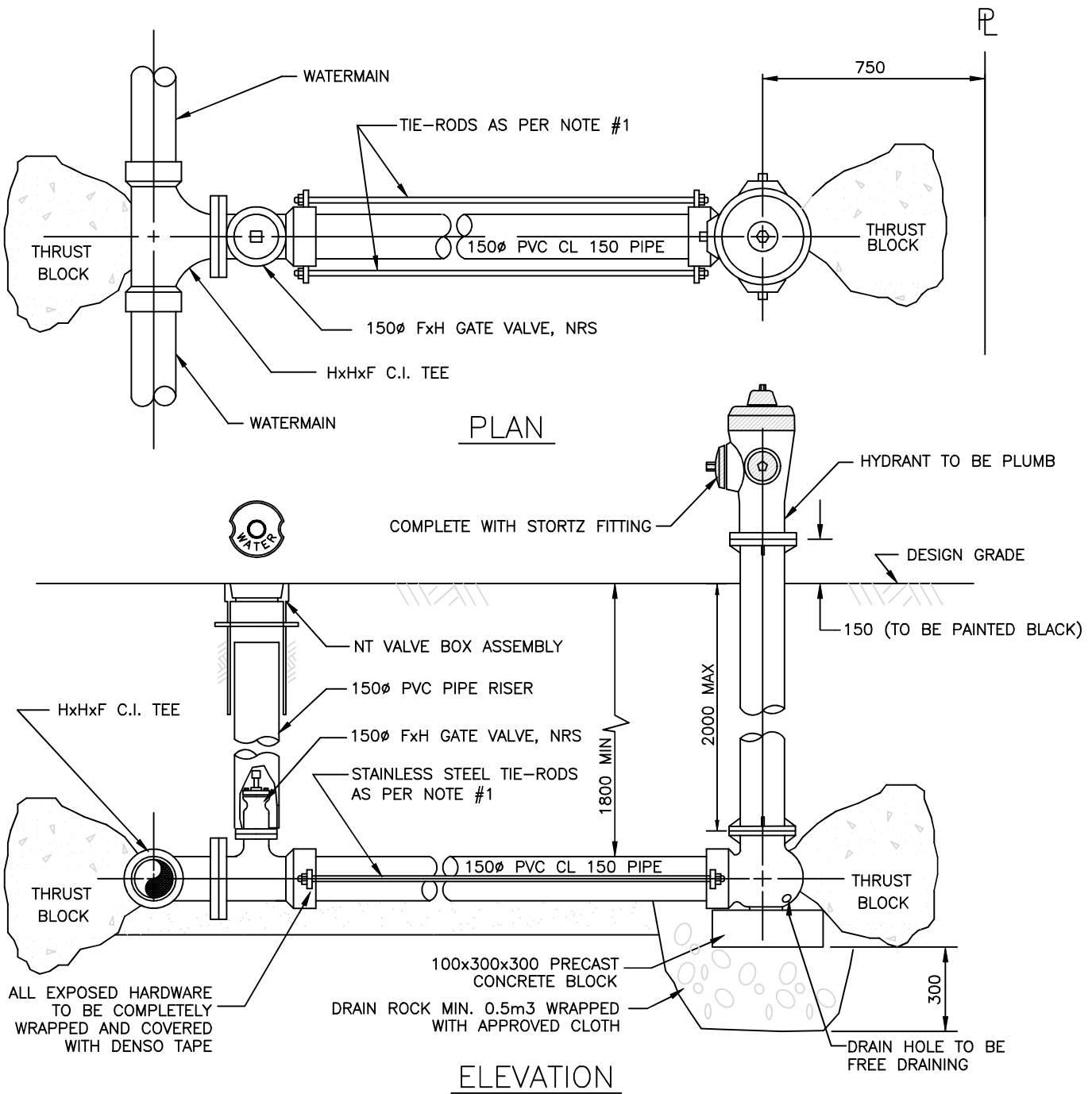

**NOTES:**

- 1) City of Salmon Arm Fire Hydrants to be 150mm and Tie-Rods and Nuts to be in accordance with CSA approved Materials List.
  - 2) Hydrant Body & Bonnet to be Painted per CoSA Approved Materials List
- Bonnet and Caps Painted as Follows:
- 0 to 500 GPM – Yellow
  - 500 to 1000 GPM – Blue
  - 1000 to 1000+ GPM – Green

**CITY OF SALMON ARM**

No.	REVISION	Date
A	SDSB 4293 – ISSUED FOR APPROVAL	06/12/23

APPROVED



FIRE HYDRANT ASSEMBLY

SPECIFICATION  
DRAWING No.:

W-3

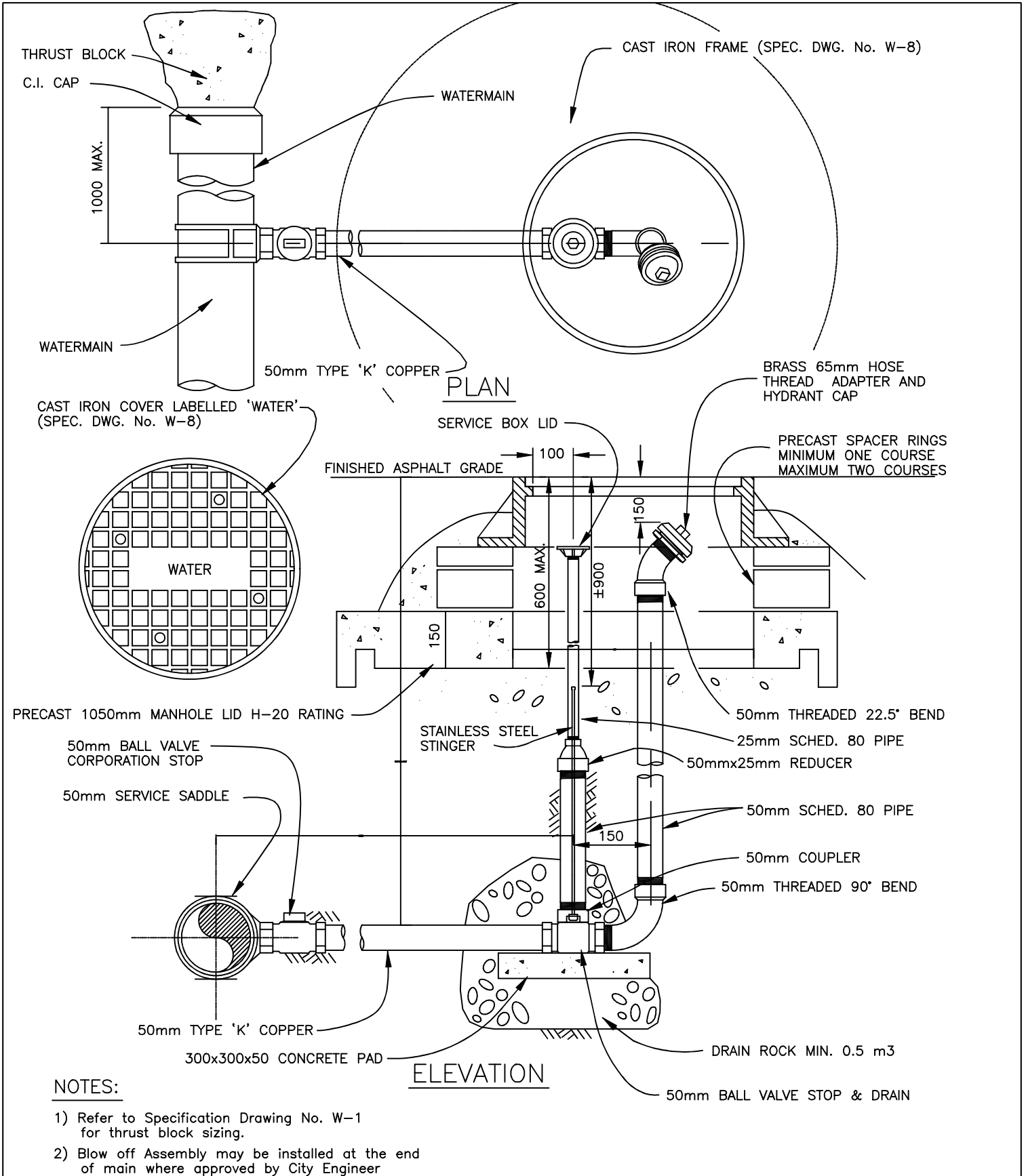

<b>CITY OF SALMONARM</b>		
No.	REVISION	Date
A	SDSB 4293 – ISSUED FOR APPROVAL	06/12/23

APPROVED

TYPICAL BLOW-OFF ASSEMBLY

SPECIFICATION  
DRAWING No.:

W-4

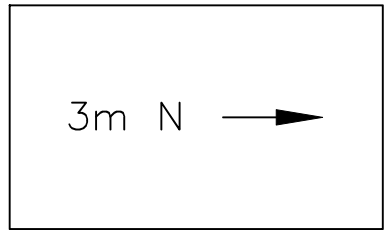

TYPICAL PLATE IDENTIFICATION

NOTE:

- 1) Stamped lettering to be 20mm wide x 40mm high.

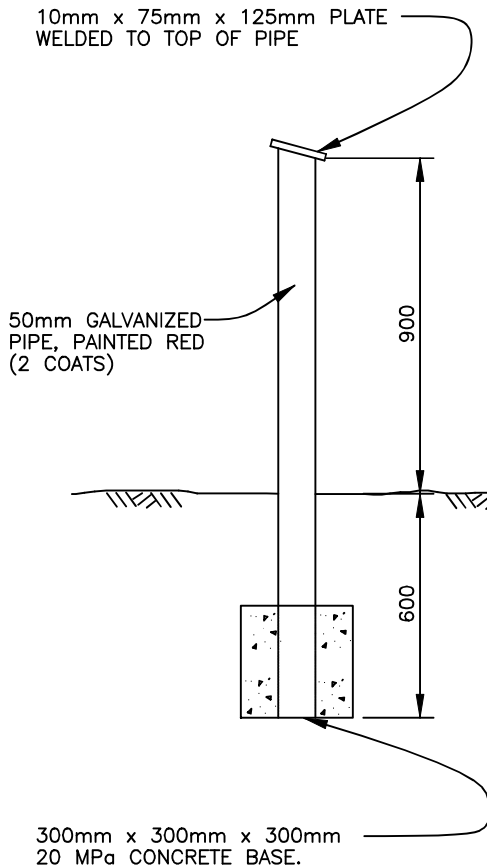

VALVE MARKER

NOTE:

- 1) Valve marker to be installed at location designated by the City Engineer, where required.

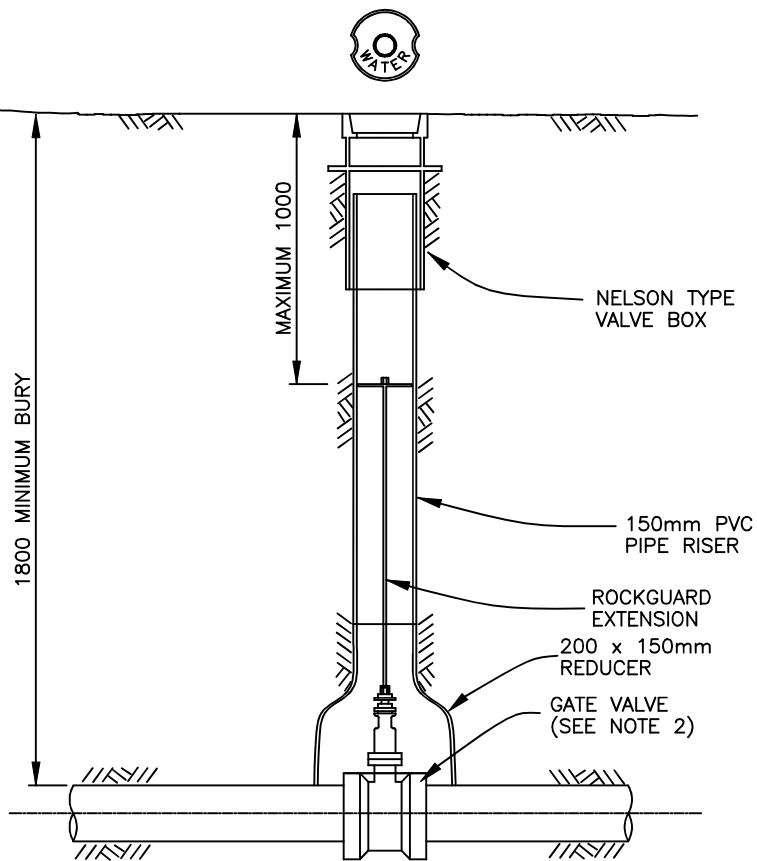

VALVE BOX & RISER

NOTES:

- 1) Valve box not to bear on pvc pipe riser.
- 2) Refer to Specification Drawing No. UT-1 & UT-2, Typical Utility Trench.

**CITY OF SALMONARM**

No.	REVISION	Date
A	SDSB 4293 – ISSUED FOR APPROVAL	06/12/23

APPROVED



STANDARD VALVE BOX

SPECIFICATION  
DRAWING No.:

W-5



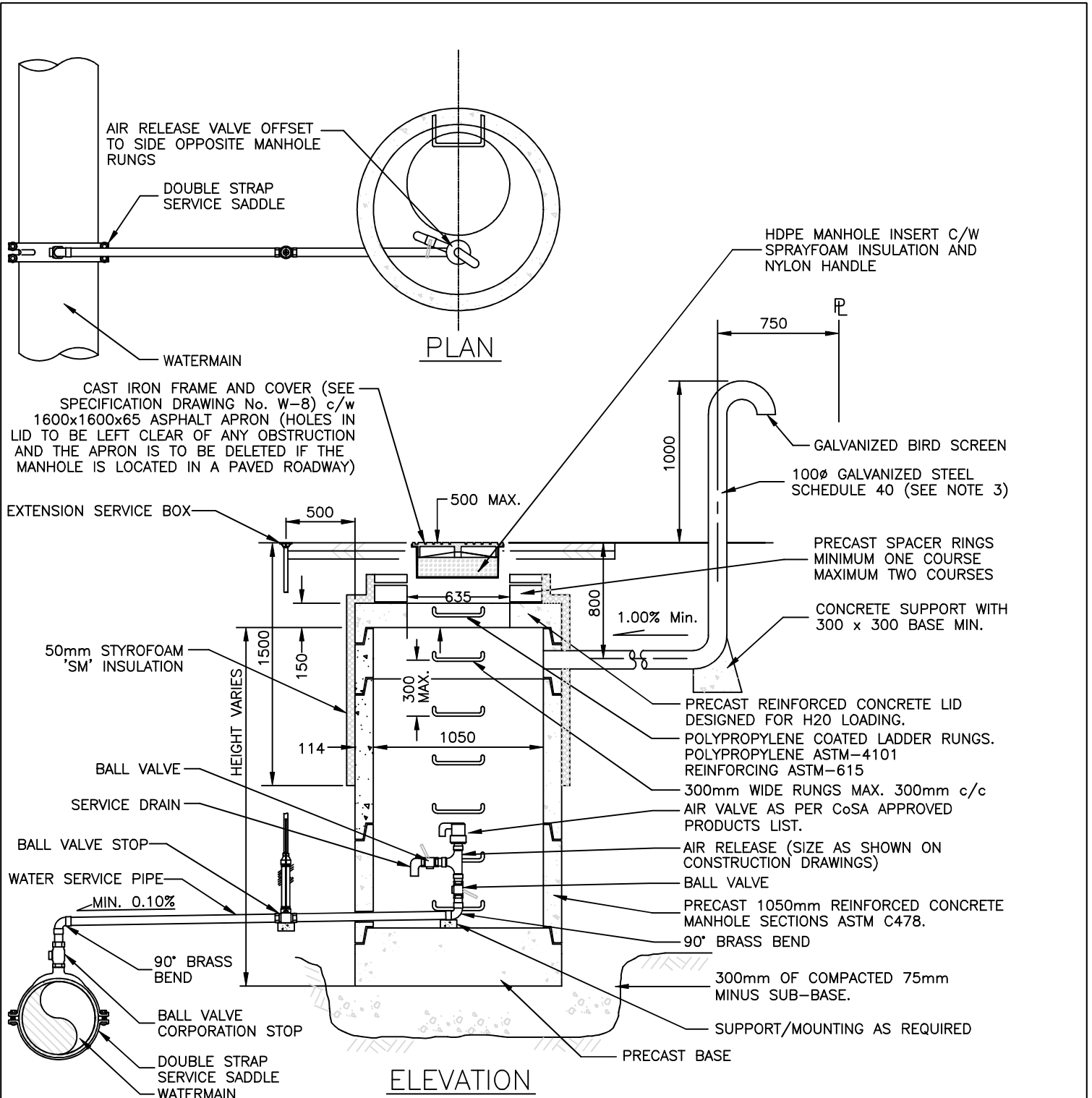

**NOTES:**

- 1) Frame & cover to be set at 5mm below finished asphalt design grade and cross-fall.
- 2) 100Ø vent to be used in rural areas only.
- 3) Combination Air Release where required by City Engineer.
- 4) Subject to soil conditions and location, chamber to have drain to storm sewer, ditch, or approved alternative c/w back-flow prevention.

PIPE SIZE (mm)	AIR RELEASE VALVE (mm)
200 AND SMALLER	25
250 TO 350	50
400 TO 500	75

<b>CITY OF SALMON ARM</b>		
No.	REVISION	Date
A	SDSB 4293 – ISSUED FOR APPROVAL	06/12/23

APPROVED

AIR RELEASE VALVE (100 to 500mmØ watermain)

SPECIFICATION DRAWING No.: W-6

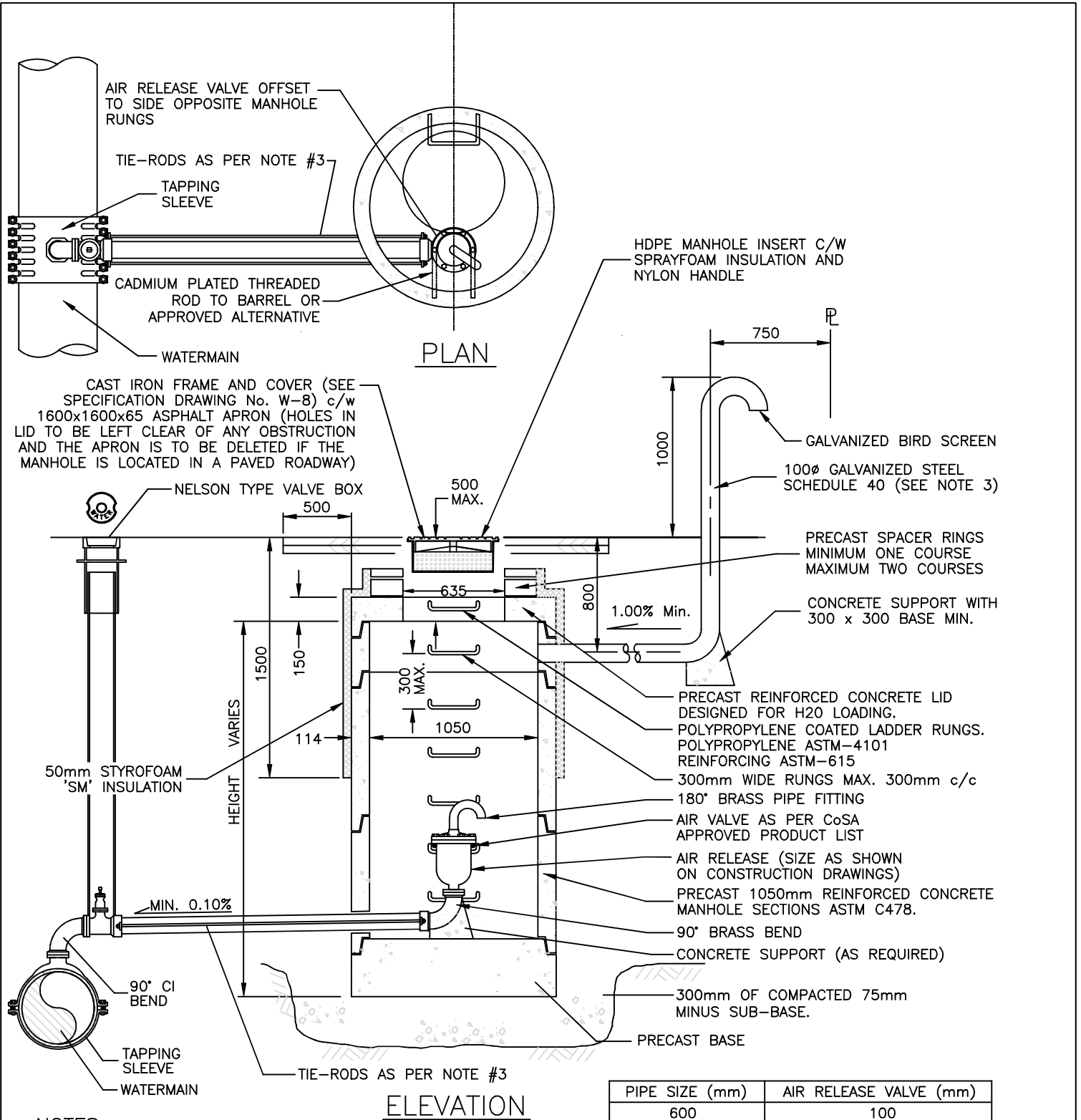

PIPE SIZE (mm)	AIR RELEASE VALVE (mm)
600	100
750 TO 1050	150
1200	200

**NOTES:**

- 1) Frame & cover to be set at 5mm below finished asphalt design grade and cross-fall.
- 2) 100Ø vent to be used in rural areas only.
- 3) Tie-Rods and Nuts to be as per Section 2B – Water Distribution Works, Clause 4.2.7 and 4.2.8.
- 4) Combination Air Release where required by City Engineer.
- 5) Chamber to have drain to storm sewer, ditch, or approved alternative c/w back-flow prevention.

<b>CITY OF SALMON ARM</b>		
No.	REVISION	Date
A	SDSB 4293 – ISSUED FOR APPROVAL	06/12/23

APPROVED

AIR RELEASE VALVE (800 to 1200mmØ watermain)

SPECIFICATION DRAWING No.: W-7

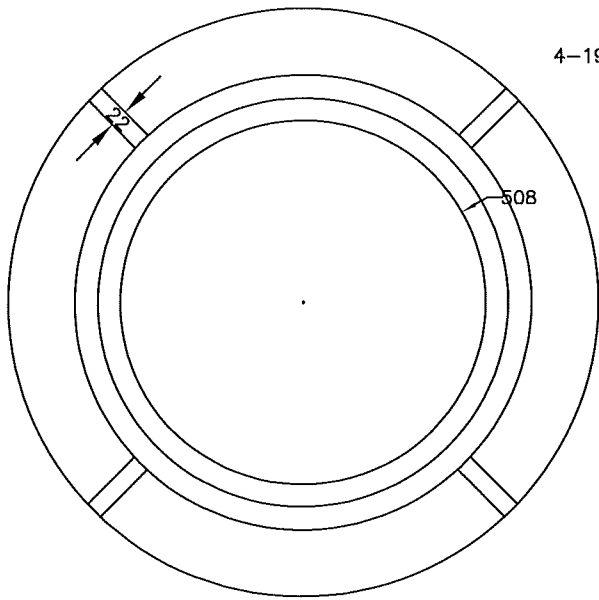

FRAME PLAN

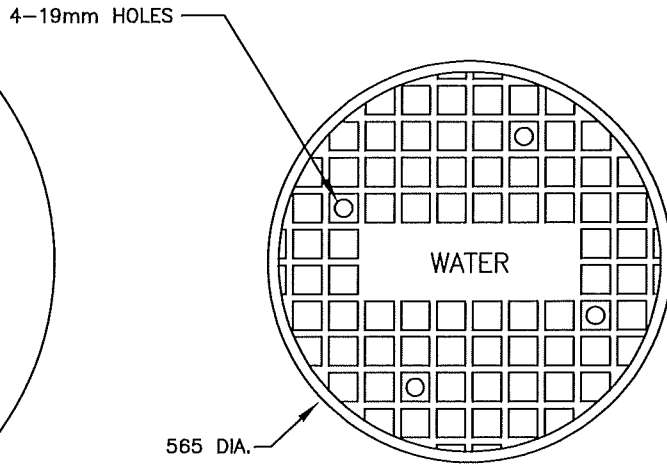

COVER PLAN

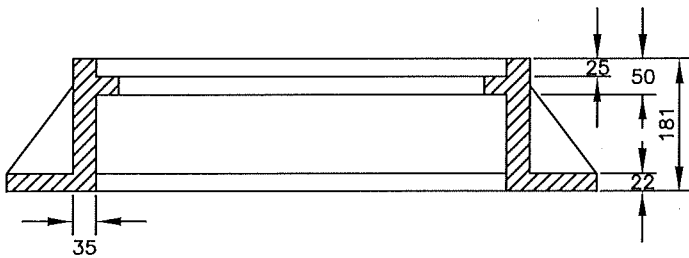

FRAME ELEVATION

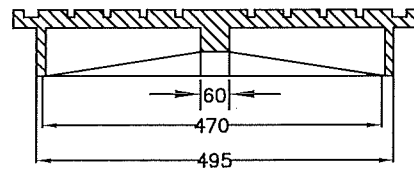

COVER ELEVATION

NOTES:

- 1) Frames and covers are to be designed to withstand H-20 loading.
- 2) Air Valve manhole covers shall be labelled: "WATER"
- 3) Blow-off Assembly manhole covers shall be labelled: "WATER"
- 4) Water meter manhole covers shall be labelled: "WATER"
- 5) No low profile cast iron frame allowed, unless approved by the City Engineer.

**CITY OF SALMON ARM**

No.	REVISION	Date
A	SDSB 4293 – ISSUED FOR APPROVAL	06/12/23

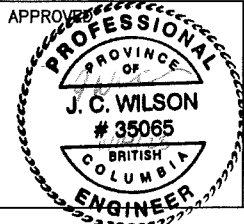

H-20 MANHOLE FRAME & COVER

SPECIFICATION  
DRAWING No.:

W-8

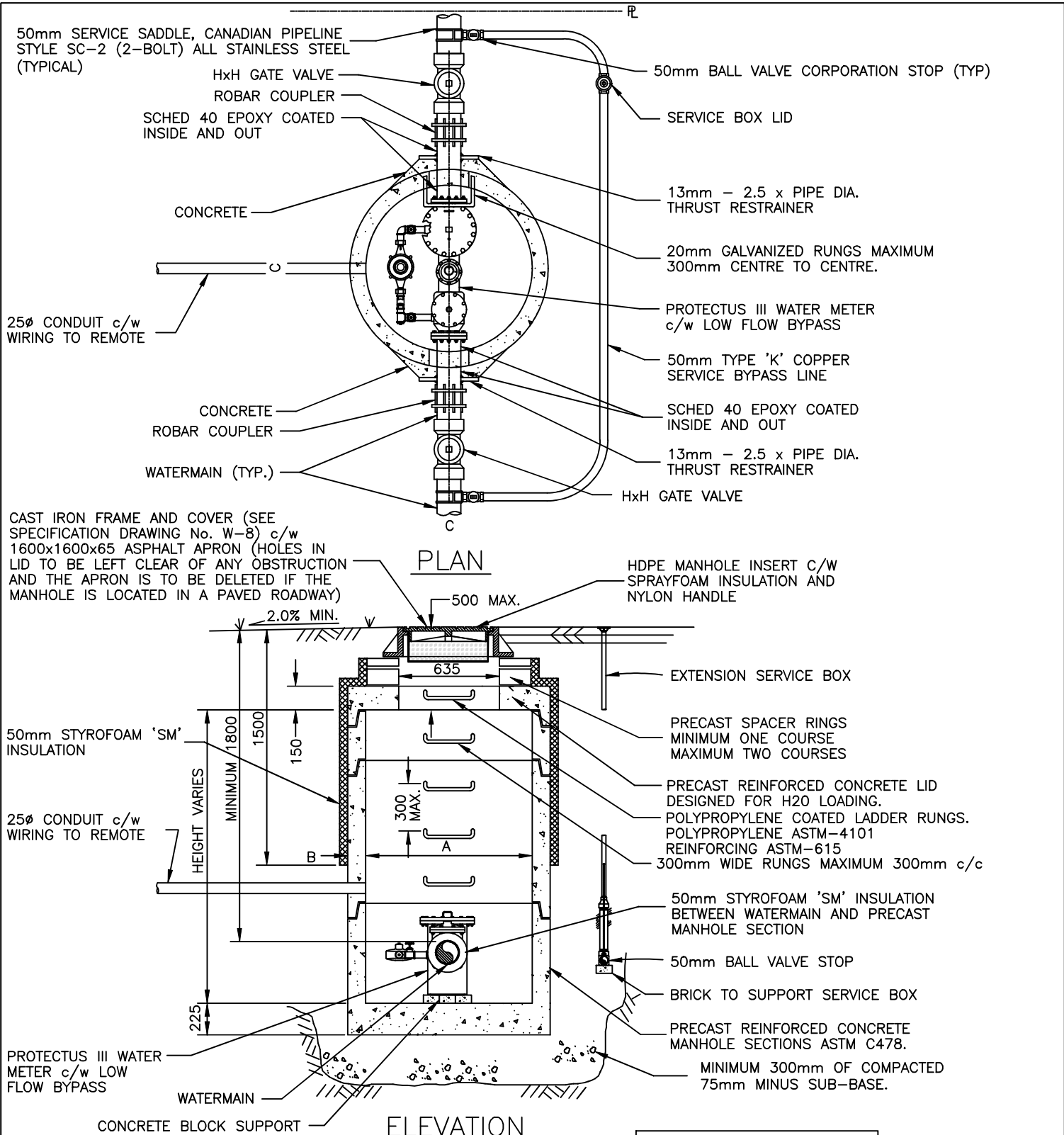

**NOTES:**

- 1) Frame & cover to be set at 5mm below finished asphalt design grade and cross-fall.
- 2) Chamber to have drain to storm sewer, ditch, or approved alternative c/w back-flow prevention.

METER SIZE	A	B
100	1500	170
150	1800	200

<b>CITY OF SALMONARM</b>		
No.	REVISION	Date
A	SDSB 4293 – ISSUED FOR APPROVAL	06/12/23

APPROVED

FIRE SERVICE WATER  
VAULT/METER DETAIL

---

SPECIFICATION  
DRAWING No.:

W-9

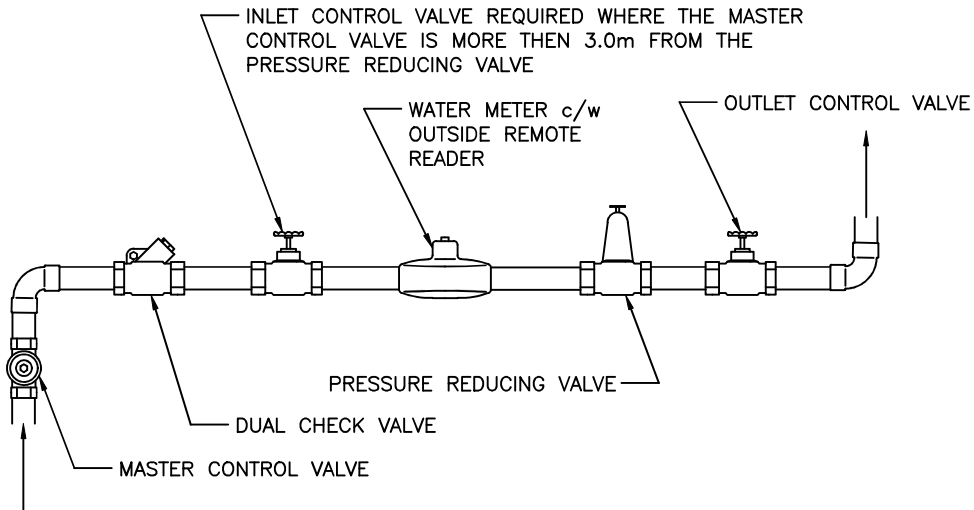

**NOTES:**

- 1) Water meter c/w outside remote reader supplied by City of Salmon Arm.
- 2) Meter to be installed as the first fixture on the service connection. All other fixtures to be installed down stream of the outlet control valve, such that all water consumption is metered.
- 3) Remote reader to be mounted on outside wall near front of building, adjacent to the BC Hydro meter.
- 4) Wire to remote reader to be encased in 13mm schedule 40 PVC or approved equivalent, (optional).
- 5) Where the water meter is installed in the crawl space the water meter must be located within 1.20m of the access hatch.
- 6) City Engineer (or Building Inspector) may require higher level of backflow protection than a dual check valve depending on the proposed use.
- 7) Piping on each side of meter must be adequately supported to the satisfaction of the Building department.
- 8) Meter must be on horizontal plane and upright.
- 9) Where a standard water meter setter is not used then there should be a minimum distance of 225mm between any wall and a meter or meter tree. The meter assembly should be appropriately secured to the wall or floor.
- 10) Valves are required adjacent to meters (inlet & outlet side). Additional valve may be installed in individual units if required.
- 11) The area for 600mm in front of the meter shall be free of obstruction to allow for convenient reading and servicing of the meter, also 1.20m headroom must be provided in this area.
- 12) In no case shall a meter be installed in a bathroom or bedroom.
- 13) The master control valve must be easily accessible and located immediately after the water service enters the building and immediately ahead of the meter.
- 14) 19Ø and 25Ø services ONLY. Can be used for a 38Ø and 50Ø upon City Engineer's approval.

**CITY OF SALMON ARM**

No.	REVISION	Date
A	SDSB 4293 – ISSUED FOR APPROVAL	06/12/23

APPROVED



RESIDENTIAL WATER METER

SPECIFICATION  
DRAWING No.:

W-10

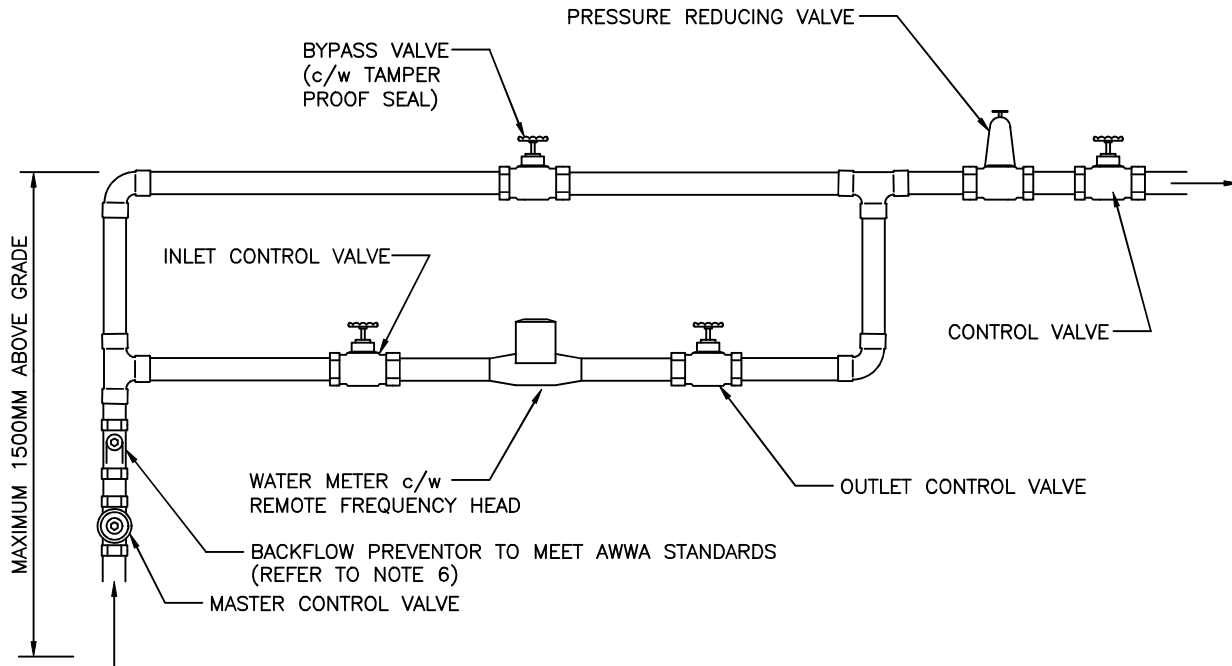

**NOTES:**

- 1) Water meter c/w remote frequency head reader supplied by City of Salmon Arm.
- 2) Meter and Bypass to be installed as the first fixture on the service connection. All other fixtures shall be installed downstream of the bypass assembly. Bypass is only mandatory on services exceeding 38mm (1.5")
- 3) The bypass valve to be wired closed and sealed.
- 4) Type of backflow preventor to commensurate to the degree of hazard as established by CAN/CSA B64.10 (most current) and approved by the City of Salmon Arm.
- 5) Piping on each side of meter must be adequately supported to the satisfaction of the Building department.
- 6) Meter must be on horizontal plane and upright.
- 7) Where a standard water meter setter is not used then there should be a minimum distance of 225mm between any wall and a meter or meter tree. The meter assembly should be appropriately secured to the wall or floor.
- 8) Valves are required adjacent to meters (inlet & outlet side). Additional valve may be installed in individual units if required.
- 9) Alternate arrangement of piping and valving must have the approval of the Building department or Project Engineer prior to installation.
- 10) The area for 600mm in front of the meter shall be free of obstruction to allow for convenient servicing of the meter. This area also requires a minimum of 2.0m headroom.
- 11) In no case shall a meter be installed in a bathroom or bedroom.
- 12) The master control valve must be easily accessible and located immediately after the water service enters the building and immediately ahead of the meter.

**CITY OF SALMON ARM**

No.	REVISION	Date
A	SDSB 4293 – ISSUED FOR APPROVAL	06/12/23

APPROVED



COMMERCIAL WATER METER

SPECIFICATION  
DRAWING No.:

W-11

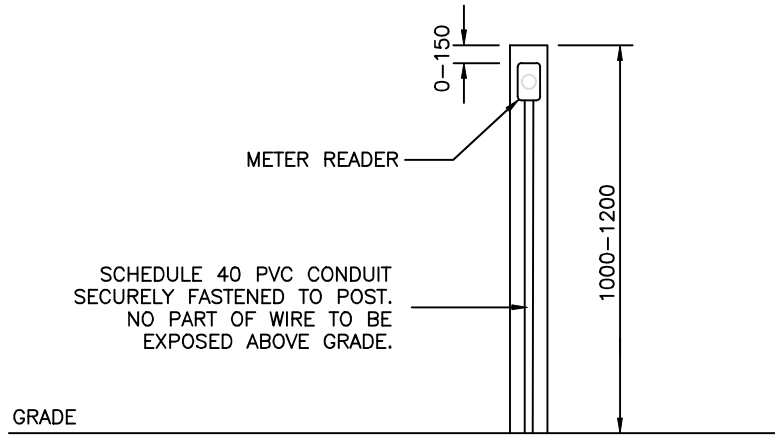

ELEVATION

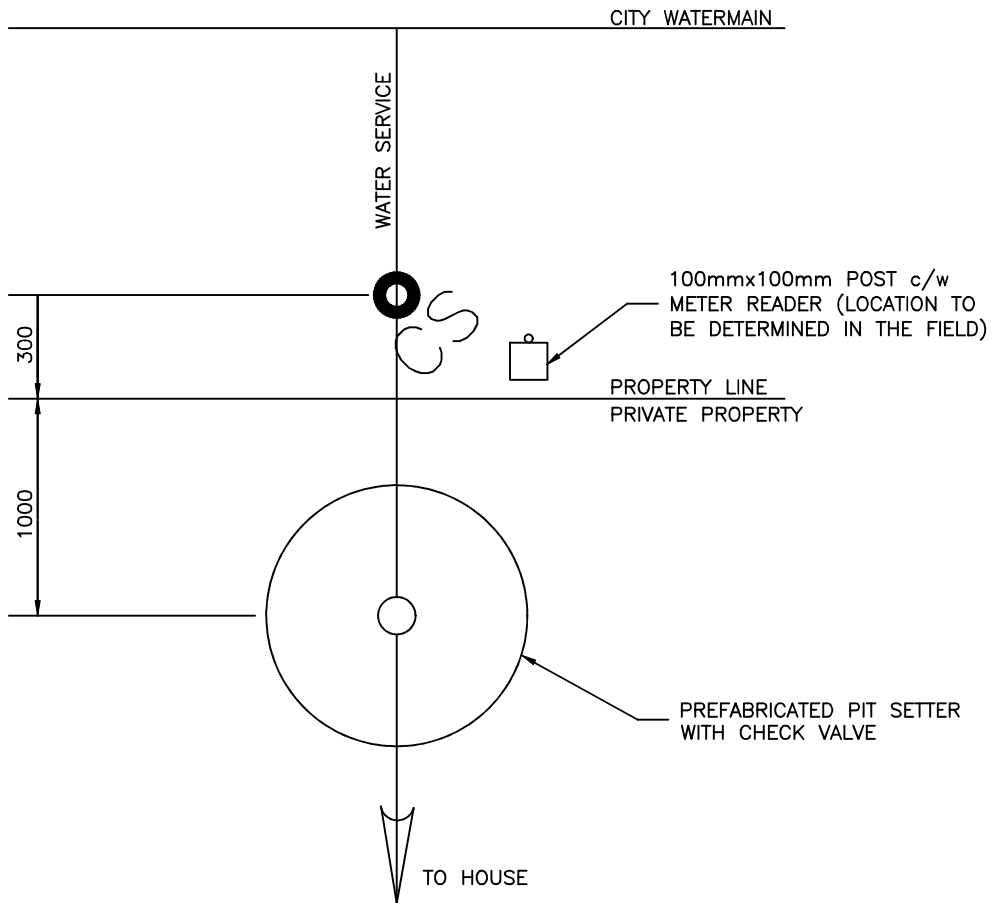

PLAN VIEW

**CITY OF SALMONARM**

No.	REVISION	Date
A	SDSB 4293 – ISSUED FOR APPROVAL	06/12/23

APPROVED



PIT SETTER

SPECIFICATION  
DRAWING No.:

W-12

# **Subdivision and Development Servicing Bylaw No. 4293**

## **Schedule “B” – Part 3**



# **CITY OF SALMON ARM**

## **CONSTRUCTION SPECIFICATIONS**



The City of Salmon Arm Construction Specifications shall be the Master Municipal Specifications and Standard Detail Drawings contained in the Master Municipal Construction Documents (MMCD) Platinum Edition Volume II (The Master Municipal Construction Documents Association 2009) as amended from time to time, and as modified by this document.

Where this document is in conflict with the Master Municipal Specifications, this document takes precedence.

### **1.1 Related Work**

Add: .8 Concrete Reinforcement Section 03 20 01

### **3.5 Concrete Placement**

Add: .12 When concrete forms are removed all debris shall be immediately removed to the contractor's disposal site. During the interval when the forms are stripped and the concrete works are backfilled any grade separations shall be marked to provide for pedestrian safety.

### **3.19 Sign Post Bases**

Add: .1 Sign post bases shall be installed in accordance with Specifications Drawings No. SP-1. Where a sign post base protrudes above a sidewalk it shall be marked to advise pedestrians until such time as the sign post is installed.

## **1.6 Permits and Tests**

Add: .2 A copy of all necessary permits shall be provided to the Contract Administrator and City of Salmon Arm.

## **2.14 Luminaires**

Add: .6 Luminaires installed in residential areas shall conform to IES Classification Type III.

Add: .7 Luminaires installed in commercial/industrial areas and at intersections shall conform to IES Classification Type V.

## **2.19 Power Base**

Add: .1 Davit power base shall be completed with padlock hasp access door, 280mm top bolt circle pattern for 4-25mm bolts and 380mm bottom bolt circle pattern for 4-25mm x 920mm anchor bolts.

Add: .2 Ornamental power base shall be completed with padlock hasp access door, 250mm top bolt circle pattern for 4-19mm bolts and 380mm bottom bolt circle pattern for 4-19mm x 600mm anchor bolts.

## **2.20 Service Panel**

Add: .1 Davit service panel shall be minimum 30 amp service panel complete with TEC bypass switch.

Add: .2 Ornamental service panel shall be minimum 20 amp service panel complete with TEC bypass switch.

**1.5 Inspection and Testing**

Add: .2 Sieve analysis of sub-base and base course aggregate required prior to placement.

**2.6 Drain Rock**

Replace: .1 Drain rock shall be clean round stone or crushed rock conforming to the following grading limits:

Sieve Size	% Passing by Mass
37.5 mm	95-100
19 mm	0-8
0.075 mm	0-3

**2.7 Granular Pipe Bedding and Surround Material**

Replace: .1 Granular pipe bedding and surrounding aggregate in the pipe zone shall conform to the following specifications:

- .1 Class 'A' Bedding is where the pipe is bedded in a continuous monolithic cradle of concrete as indicated in the CoSA approved drawings.
- .2 Class 'B' bedding shall be imported aggregate meeting the following gradation:

Sieve Size	% Passing by Mass
12.5 mm	100
4.75 mm	35-100
2.36 mm	20-70
1.18 mm	13-50
0.850 mm	8-35
0.300 mm	5-25
0.150 mm	2-15
0.075 mm	0-6

- .3 Class 'C' pipe bedding shall be native material in the trench which meets the gradation for Class "B" pipe bedding aggregate.

**2.8 Select Granular Sub-base**

Replace: .1 Sub base course aggregate shall be a 75 mm well graded sub-base course aggregate, composed of inert, clean, tough, durable particles uniform in quality and free from an excess of flat or elongated pieces, supplied conforming to the following grading limits:

Sieve Size	% Passing by Mass
75 mm	100
37.5 mm	60 – 100
19 mm	35-80
9.5 mm	25-60
4.75 mm	20-43
2.36 mm	15-35
1.18 mm	10-25
0.30 mm	3-13
0.075 mm	2-8

**2.9 Crushed Granular Sub-base**

Replace: .1 Sub base course aggregate shall be a 75 mm crushed well graded sub-base course aggregate, composed of inert, clean, tough, durable particles uniform in quality and free from an excess of flat or elongated pieces, supplied conforming to the following grading limits:

Sieve Size	% Passing by Mass
75 mm	100
37.5 mm	60 – 100
19 mm	35-80
9.5 mm	25-60
4.75 mm	20-43
2.36 mm	15-35
1.18 mm	10-25
0.30 mm	3-13
0.075 mm	2-8

**2.10 Granular Base**

Replace: .1 Base course aggregate and shouldering aggregate shall be a crushed 25 mm ‘well graded base course aggregate’, composed of inert, clean, tough, durable particles uniform in quality and free from an excess of flat or elongated pieces, supplied conforming to the following grading limits:

Sieve Size	% Passing by Mass
25 mm	100
19 mm	80–100
9.5 mm	50-100
4.75 mm	35-70
2.36 mm	25-50
1.18 mm	15-35
0.30 mm	5-20
0.075 mm	2-8

**3.6 Surface Restoration****.7 Permanent pavement restoration**

Replace: .5 Restore pavement as per City Supplemental Standard Drawing UT-1B.

Add: .1 All asphalt shall be saw cut 500 mm wider and longer than the surface dimensions of the actual trench excavation. This saw cut must extend cleanly through the existing asphalt to the base material prior to asphalt removal.

Add: .2 If the thickness of the existing asphalt is greater than 75 mm, grind it to a depth of 40 mm and a width of 200mm along the saw cut edge. This can be done just prior to the final asphalt restoration.

Add: .3 Where the edge of the saw cut or milled asphalt, whichever is wider, extends into the travel lane, it should be extended to the mid point of that lane. Where the edge extends past the mid point of the travel lane, it should be extended to the far edge of that travel lane.

Add: .4 Where the edge of the saw cut or milled asphalt, whichever is wider, is less than 1.5m from the lip of gutter or edge of paved shoulder, it should be extended to the lip of gutter or edge of paved shoulder.

Add: .5 When an area of existing asphalt between two transverse trenches is less than one third (1/3) of the total area of the proposed paving of the two trenches plus the area between them (based on the shortest trench), the existing asphalt shall be removed and the area paved in conjunction with the paving of the two trenches.

Add: .6 Regardless of 7.5.5, if the longitudinal distance between two trenches is less than three (3) meters it shall be removed and the area paved in conjunction with the paving of the two trenches.

Add: .7 Longitudinal trenches must be paved with a paving machine.

Add: .8 Hot-mix paving shall meet the thickness of the existing pavement or that shown on the design drawings, whichever is greater.

Add: .9 Vertical faces and the surface of the bottom lift of asphalt must be painted with bituminous material prior to hot mix paving.

Add: .10 Where applicable, asphalt shall be keyed in as per the requirements of Section 32 12 16S 3.7.3 Longitudinal Joints.

**3.4 Placing**

Replace: .4 Place material to full width in uniform layers not exceeding 200mm in loose thickness except that the top 500mm shall be constructed in layers not exceeding 100mm in loose thickness and compact to specified densities.



**1.0 GENERAL**

Add: .2 Contract Administrator - As referenced to in this specification applies the designated project representative, approved by the City of Salmon Arm. The Contract Administrator must be designated prior to the onset of the project.

**1.5 Measurement and Payment**

Add: .9 Leveling coursing shall be included in the paving unit price.

Add: .10 Patching and tie-ins done in conjunction with projects over 100 tonnes shall be included in the paving unit price.

**2.0 PRODUCTS****2.1 Materials**

Replace: .1 Asphalt cement: to CGSB-16.3-M90, Grade 80-100, Class A; or with equivalent PG asphalt cement.

Add: .1.2 The asphalt cement shall be homogenous, free from water, and shall not foam when heated to 175 °C.

Replace: .3.2 Gradations to be with the limits specified when tested to ASTM 136 and ASTM C117.

**Table 2.1.3.2 - Hot Mix Asphalt Aggregate Gradation Specification**

Sieve Designation	Percent Passing	
	Upper Course #1 (1)	Upper Course #2 (2)
25 mm	-	-
19 mm	100	-
12.5 mm	84-99	100
9.5 mm	73-88	-
4.75 mm	50-75	55-75
2.36 mm	35-55	38-58
1.18 mm	27-46	28-47
0.600 mm	18-36	20-36
0.300 mm	10-26	10-26
0.150 mm	4-17	4-17
0.075 mm	3-8	3-8

- Note (1) Upper Course #1 to be used for Arterial, Industrial, Commercial, Residential and Lane Road Classifications.
- (2) Upper Course #2 to be used on multi-use pathways and sidewalks
- Replace: .3.6 Sand Equivalent: to ASTM D2419. Min:50 (New Arterial), Min:40 (All other street classifications).
- Replace: .3.10 Lightweight particles: to ASTM C123. Maximum % by mass less than 1.95 relative density:
- .1 Surface course: 1.0
  - .2 Lower course: 1.5
- Replace: .3.11 Flat and elongated particles: (with length to thickness ratio greater than 5): Maximum % by mass:
- .1 Coarse aggregate, surface course: 10
  - .2 Coarse aggregate, lower course: 10
- Replace: .3.12 Crushed Particles (fraction retained on 4.75 mm sieve), 2 faces, % minimum:
- .1 New arterial streets: 85
  - .2 All other street classifications: 75

## 2.2 Mix Design

- Replace: .1 The contractor shall supply the Contract Administrator with a current 5 point mix design, under the signature of a Professional Materials Engineer. The mix design shall follow the Marshall method of mix design as outlined in the latest edition of the Asphalt Institute Manual Series No. 2 (MS-2), and shall include five separate trial values of asphalt content, using the compactive effort specified in this document.
- Replace: .2 Mixes for construction of asphalt base course should not include Recycled Asphalt Pavement (RAP).
- Replace: .3 Design of Mix: Include the following content with the trial mix design submission:
- .1 Summary statement (usually in the form of a letter to the testing agency's client) which contains, as a minimum, the following information:

- .1 Product for which the design applies and the specifying agency.
  - .2 Method of sample preparation (eg. laboratory batches, plant mix samples), date performed, and definitions of the procedure utilized (eg. ASTM D6926 or other).
  - .3 Reference to design aggregate gradation and details of aggregate stockpile (or bin numbers), blending rates utilized to achieve the design gradation.
  - .4 Grade and refinery source of asphalt cement used in the mix design procedure, including recommended plant mixing and mixture compaction temperature ranges to be applied during production and compaction operations.
  - .5 A statement identifying the recommended target asphalt content with an accompanying tabulation of anticipated Marshall properties at that target value. The tabulation should include an accompanying column showing the specified Marshall property requirements.
  - .6 A concluding statement that identifies, to the testing agency's client, that job mix formula details contained in the submission represent a starting point for actual plant mix production, and that Marshall properties of actual plant mix should be verified.
- .2 A tabulation and graphical representation of all Marshall properties at each trial asphalt content in the mix design. It should be noted that the mix design is meaningless unless the report clearly states the basis of asphalt content reporting (either % by weight of mix or % by weight of aggregate).
- Data to be shown shall include (but not limited to):
- .1 Number of Marshall blow.
  - .2 Marshall relative density of specimens.
  - .3 Marshall stability (ASTM D6927).
  - .4 Marshall flow (ASTM D6927).
  - .5 Voids in Mineral Aggregate (V.M.A.).
  - .6 Air Voids (ASTM D3203).

- .7 % Voids filled with asphalt.
- .8 Maximum relative density (ASTM D2041).
- .9 Asphalt absorption (ASTM D4469).
- .10 Index of retained stability (optional - depends on agency)
- .11 Film thickness (optional - depends on agency)

In addition, the following materials properties must be shown:

Relative density of coarse aggregate (ASTM C127).

Relative density of fine aggregate (ASTM C128).

Relative density of combined aggregate.

Relative density of asphalt cement.

- .3 Current temperature - viscosity curve from the asphalt supplier (testing agency to super-impose mixing and compaction temperature ranges based on viscosity requirements shown in ASTM D6926).
- .4 Tabulated graphical presentation of aggregate(s) used in trial mix designs. The specified gradation “envelope” should be shown on both forms of presentation, as should production tolerance limits if contained in the Specifications.
- .5 Mix Physical Requirements to meet Table 2.2.3.5 below.

**Table 2.2.3.5 – Specified Physical Requirements of Hot Mix Asphalt**

Property	Mix Type	
	Upper Course #1	Upper Course #2
Blows per face	75	50
Stability @ 60°C, kN (min)	8.0	5.5
Flow Index, 0.25 mm units	8 - 14	8 - 15
Voids in Mineral Aggregate %	14 - 17	14 - 17.5
Air Voids in mixture		
- at design A.C.	4.0% ± 0.2%	4.0% ± 0.2%
- allowable production range	3 - 5	3 - 5
Index of Retained Stability after immersion in water for 24 hrs @ 60°C (min)	85	85

- .1 The asphalt content of hot mix asphalt which is produced in accordance with the approved Marshall design shall be maintained within plus or minus 0.3 % of the approved design asphalt content.
  - .6 If anti-strip additives are not included in the mix design submission then the following test results must be submitted:
    - .1 Index of Retained Stability - minimum 85%
    - .2 Tensile Strength Ratio - minimum 80%
  - .7 Upper course #2 mix design requirements for multi-use pathways and sidewalks is to be used as a guideline for asphalt suppliers. If a cost effective, alternative mix design is submitted, the Contract Administrator may consider it for use and is subject to the approval of the City of Salmon Arm.
- Add: .4 Job Mix Formula.
- .1 Subject to approval by the Contract Administrator, the aggregate proportioning, target gradation, asphalt content and air void content from the Mix Design will become the Job Mix Formula for the supply of hot mix asphalt.
  - .2 Once established, no alterations to the Job Mix Formula will be permitted unless the Contractor submits a new Job Mix Formula and approved by the Contract Administrator.
  - .3 If the sum of any alterations to the Job Mix Formula is in excess of any one of the following limits, a New Mix Design is required.
    - ± 5.0 % passing the 4.75 mm sieve size
    - ± 1.5 % passing the 0.075 mm sieve size
    - ± 0.30 % asphalt content

### 3.0 EXECUTION

#### 3.1 Plant and Mixing Requirements.

- .1 Batch and continuous mixing plants:
- Replace: .3 Before mixing, dry aggregates to a moisture content not greater than 1% by mass or to a lesser moisture content if required to meet mix design requirements.

Replace: .9 RAP should not be incorporated into the mix.

.11 Mixing time:

Add: .3 Mixing period and temperature to produce a uniform mixture in which particulates are thoroughly coated.

.2 Dryer drum mixing plant:

Replace: .1 RAP should not be incorporated into the mix.

.4 Mixing tolerances:

Replace: .1 Permissible variation in aggregate gradation from job mix (percent of total mass):

.1	4.75 mm and larger	±5.0
.2	2.36 and 1.18 mm	±4.0
.3	0.600 mm and 0.300 mm	±3.0
.4	0.150 mm	±2.0
.5	0.075 mm	±1.5

Replace: .3 Mixing temperature requirements should be within ± 15°C of the design mix temperature designated in the accepted mix design. Plant mix outside this range at the point of discharge may be rejected at the discretion of the contract administrator.

### 3.2 Equipment

Add to .1 .1 Pavers must be capable of placing a standard mat width not less than 3.0 m and must be capable of paving wider widths in 150 mm and 300 mm increments by means of equipment supplied by the manufacturer of the equipment. The screed must include a tamping bar or strike-off device

.2 Control of the screed must be by automatic sensing devices. Longitudinal control must be by a sensor that follows a string-line, ski or other reference. The grade sensor must be moveable and mounts provided so that grade control can be established on either side of the paver. A slope control sensor must be provided to maintain the proper transverse slope of the screed.

**3.3 Preparation**

- Add to .1 .1 All preparation work, including final compaction with vibratory roller immediately prior to paving shall be the responsibility of the paving contractor.
- .2 Upon completion of the sub-grade preparation, the subgrade may be proof rolled in the presence of the Contractor with a loaded single axle truck with a rear axle load of 8165 kg where requested.

Any areas found to be soft or wet shall be excavated and backfilled with select granular subbase and compacted to 100% Standard Proctor density (ASTM D-698) by the contractor prior to paving.

- Add to .5 .1 Prime coat application to granular base course surfaces will not be required.
- .2 Tack coat shall be applied using an asphalt distribution truck at a distribution rate agreed upon with the City of Salmon Arm.

**3.5 Placing**

- Add to .1 .1 Late season public paving operations and all private development paving operations must be completed by October 15<sup>th</sup>. The City of Salmon Arm can waive the placement conditions in public traffic zones after this time. If a waiver is issued, it does not relieve the asphalt supplier and/or paving contractor of providing materials and workmanship that meets the standards set out in this specification to the best of their ability. The waiver is only valid if the placing conditions in Section 3.5.3 are not satisfied during paving. The waiver should be included in the contract documents once the project completion date is determined. The following asphalt properties and paving conditions should be considered individually in the waiver agreement:
- .1 Asphalt compaction
  - .2 Asphalt thickness
  - .3 Asphalt mixing temperature
  - .4 Marshall mix properties
  - .5 Workmanship (includes smoothness and segregation)
  - .6 Base course temperature and surface condition
  - .7 Ambient air temperature and weather conditions

- .2 Minimum 48 hours notice shall be given to the City of Salmon Arm by the Contractor prior to the commencement of paving works. All costs incurred by the City by contractor initiated scheduling changes with less than 48 hours notice shall be borne by the contractor.
- .3 The Contractor should schedule works such that disruption of normal traffic, and inconvenience to residents, in the working area is kept to a minimum. The Contractor shall provide all certified flagpersons, cones, barricades, lights, signs, etc., required to maintain safe and adequate traffic flow at each construction site. Every effort shall be made to maintain the movement of traffic at all times, with minimum delays, and provision shall at all times be made for emergency vehicles. All traffic control signs and barricades must be at least to the standard set out in the Traffic Control Manual for Work on Roadways published by the B.C. Ministry of Transportation. Where specified on the drawings, construction advisory signs, to the City of Salmon Arm requirements, shall be posted at each end of the construction site.
- .4 Traffic shall not be permitted on the finished pavement surface until the asphalt surface has cooled to atmospheric temperature. It shall be the responsibility of the Contractor, to supply all traffic control for direction and safe movement, until such time as the asphalt has cooled.

.3 Placing Conditions:

Add to .2 .1 Surfaces onto which bituminous concrete pavement is placed shall be above 5°C.

.4 Place asphalt concrete in compacted lifts of thickness as shown on Contract Drawings:

Replace: .3 Maximum lift thickness not to exceed 75 mm.

Add: .4 Minimum lift thickness should be at least 3 times the nominal maximum aggregate size to ensure aggregate can align themselves during compaction to achieve required density and also to ensure mix is impermeable. For example if the nominal maximum aggregate size as shown on the mix design is 16.0 mm the minimum lift thickness would be 48 mm.



Add: .8 The thickness of the asphalt concrete pavement shall be substantially uniform and the minimum compacted thickness shall not be less than specified in the Contract Documents and this specification. The completed asphalt surface shall conform to the required line, grade and cross-section, to an accuracy of  $\pm 6$  mm. The finished asphalt grade shall be 6 mm higher than the elevation of the top of water valves, manhole frames and covers, catch basins, and lip of the gutter.”

Add: .9 Paving must commence within five (5) business days of milling or pulverizing. Exemptions may be granted by the City of Salmon Arm due to inclement weather.

### 3.6 Compaction

Replace: .1 Roll asphalt continuously to average density not less than 97% of the laboratory compacted Marshall relative density in accordance with ASTM D6926 with no individual test less than 95%.

### 3.7 Joints

#### .1 General

Add: .4 Tie-ins to existing pavement shall be made by cutting back the existing pavement to sound material as necessary to produce a neat, vertical face with a straight edge. Prior to placing asphaltic concrete, exposed faces and other abutting structures shall be painted with liquid asphalt and heated to 66°C by the Contractor.

Add: .5 When placing final pavement layer against concrete curbing, compacted pavement must meet the gutter at a minimum of 3mm above to a maximum of 10mm above and along the entire lip of the gutter.

#### .3 Longitudinal joints

Add: .8 Longitudinal joints shall be constructed hot whenever feasible. Cold longitudinal joints shall be constructed only under unavoidable conditions and with the consent of the City of Salmon Arm. Cold joints that have cooled to ambient temperature shall be saw cut or milled a width of at least 75 mm.

.9 Longitudinal joints shall be keyed in where depth of asphalt is 100mm or more. Key in depth of existing asphalt and new asphalt lift to both be a minimum 50mm and width to be minimum 100mm.

Add: .7 Where base remediation work has occurred, joints shall be offset a minimum of 300mm from edge of undisturbed base.

### **3.9 Sidewalks, Driveways and Curbs**

Add: .6 Driveway and roadway tie ins to be completed daily. Saw cuts for tie ins to be prepared at start of paving day.

### **3.11 Defective Work**

Replace: .2 Flaws in the pavement shall be corrected by removal of the complete area and the full lift involved. Pavement which is unsatisfactory in the opinion of the City Engineer by reason of faulty materials or methods of placement shall be repaired, removed, replaced or otherwise corrected.

### **3.12 Clean-Up**

Add: .2 The Contractor shall remove to a City of Salmon Arm approved dumping site all surplus materials, waste asphalt, waste concrete, surplus aggregate, and any other debris, from the site, immediately upon completion of each phase of the works which generated the surplus materials or debris.

Add: .3 Driveways, retaining walls, vegetation and other private or municipal improvements on private or municipal property or highways damaged by the Contractor shall be restored at minimum to the condition existing prior to construction and to the satisfaction of the City Engineer.

### **Add the following subsections:**

## **4.0 SAMPLING AND TESTING**

### **4.1 General**

.1 The Contract Administrator shall have access to all production processes and materials used for the work to monitor material quality as often as deemed necessary. Such inspection and testing shall not in any way relieve the Contractor of the responsibility for meeting the requirements of this specification.

.2 At least three weeks prior to commencing work, inform the Contract Administrator of the proposed source of aggregates and provide access for sampling, and provide samples of asphalt cement in accordance with Section 2.1.1.

- .3 A lot shall be defined as - A portion of the work being considered for acceptance as follows:
- 1500 m<sup>2</sup> of continuous paving production. When less than 1500 m<sup>2</sup> is produced in a construction period the actual production for that period may, at the discretion of the Contract Administrator, be added to the previously completed pavement construction; or,
  - At the Contract Administrators discretion, any portion of the work may be deemed a lot.

#### **4.2 Quality Control**

- .1 Quality Control is the responsibility of the Contractor throughout every stage for the Work from aggregate processing to the final accepted product. Tests performed by the Contract Administrator will not be considered as quality control tests.
- .2 The Contractor shall be totally responsible for production of materials and construction that meet all specified requirements.
- .3 All quality control shall be conducted by qualified personnel. The Contractor shall bear the cost of all quality control testing and consulting services.
- .4 Pre-Production testing and sampling and minimum frequencies are described in Table 4.2.4, Pre-Production Quality Control Requirements.
- .5 Post-Production testing and sampling and minimum frequencies are described in Table 4.2.5, Recommended Post-Production Quality Control Requirements.
- .6 Pre-Production Quality Control test data as specified in Table 4.2.4 shall be reported to the Contract Administrator one week prior to commencing the project, or as requested.
- .7 Post-Production Quality Control test data as specified in Table 4.2.5 shall be reported to the Contract Administrator daily as the Work proceeds.

#### **4.3 Quality Control Compliance with Specified Tolerances**

- .1 Asphalt Content, Aggregate Gradation and Mixture Properties.
- .1 The test data derived by Post-Production Quality Control mix testing, described in Section 4.2 shall be compared to the tolerances set forth in Section 2.0 of this specification. The Contractor shall document, and make

available to the Contract Administrator, any adjustments made to correct noncompliance with the specified tolerances.

- .2 The Contractor shall suspend mix production when the 2 test running average for any property is outside of the specified tolerance limits for two consecutive tests. In the event that the Contract Administrator can provide a Quality Assurance test result that confirms a Quality Control test that is outside the specified production limits the contractor shall suspend mix production. Supply shall not commence again until it is demonstrated that corrective action has been taken.

#### 4.4 Quality Assurance Sampling and Testing

- .1 Within this specification, certain requirements, limits and tolerances are specified regarding supplied materials and workmanship. Compliance with these requirements shall be determined from Quality Assurance testing as described in this section.
- .2 Quality Assurance is the responsibility of the Contract Administrator.
- .3 Initial Quality Assurance testing will be undertaken free of cost to the Contractor.
- .4 Quality Assurance sampling and testing is described in Table 4.4.4, Quality Assurance Minimum Testing Requirements.
- .5 Quality Assurance Sampling Procedures:
  - .1 Loose mix samples shall be acquired from the work site in accordance with ASTM D979, specifically Section 5.2.3 - Sampling from the Roadway Prior to Compaction.
  - .2 The timing of mix sampling shall be stratified, with each sample representing a similar production quantity.
  - .3 Core locations will be selected using representative random sampling procedures. The lot will be divided into segments meeting or exceeding the minimum frequency in Table 4.4.4 and of approximately equal area. The longitudinal coordinates will have similar spacing on roadway and transverse coordinates will be located using random numbers. Locations will determined in the office prior to sampling, approved by the contract administrator. Core sampling requires written approval by the City of Salmon Arm.
  - .4 Areas within 5.0 m of transverse joints or 0.5 m of a mat edge are excluded from compaction acceptance sampling and testing.

.6 Reporting Protocols

.1 Test reporting accuracy shall be as stipulated in the referenced test procedures, including:

- Gradation to the nearest 0.1%.
- Binder content to the nearest 0.01%.
- Air voids and compaction to the nearest 0.1%
- Thickness to the nearest 1 millimeter (mm)

.2 Lot averages shall be reported to the same accuracy as test results.

.7 The Contract Administrator must be able to provide the opportunity for the City of Salmon Arm or their representative to sample paving materials when the City of Salmon Arm deems it necessary.

**4.5 Appeal of Quality Assurance Testing Results**

.1 General

.1 The Contractor may appeal the results of acceptance testing for Compaction Standard, Asphalt Content or Air Voids for any lot subject to rejection or unit price reduction. The notice of appeal shall be in writing and submitted to the Contract Administrator within 7 days of receipt of the acceptance testing results.

.2 Appeals will only be considered if cause can be shown and requirements of Table 4.2.5 have been satisfied.

.3 Quality Control tests initiated after the Contractor's receipt of the Quality Assurance test results will not be considered when evaluating cause for appeal. Heating and remolding pavement cores for the purpose of determining asphalt content, gradation or Marshall volumetric properties is not acceptable.

.4 Only Quality Control testing during production for the subject project will be considered when evaluating cause for appeal provided test results are submitted to the Contract Administrator prior to the receipt of the acceptance testing results.

.5 Laboratories conducting acceptance testing for appeals must be CCIL certified for the subject test procedures.

.2 Asphalt Content, Compaction Standard or Air Void Appeals

- .1 The testing laboratory conducting the project acceptance sampling and testing will routinely retain companion samples sufficient for the determination of asphalt content, maximum relative density and/or Marshall relative density. Minimum companion sample size should be 10 kg for this purpose.
- .2 For asphalt content, compaction standard or air void (Marshall relative density) appeal testing, the Contractor will have the option for the testing to be done by the testing laboratory undertaking the Quality Assurance testing, or an independent testing laboratory selected by the Contract Administrator. In the event that the independent testing laboratory does not have a valid asphalt correction factor as per ASTM D6307 - Asphalt Content of Hot Mix Asphalt by Ignition Oven the lab should have the capability to perform ASTM D2172 - Quantitative Extraction of Bitumen From Bituminous Paving Mixtures.
- .3 The appeal test results will be used for acceptance and unit price adjustment, and shall be binding on both the Owner and the Contractor.
- .4 If the new asphalt content verifies that any unit price reduction or rejection applies for that Lot, the costs of the appeal sampling and testing will be borne by the Contractor. If the results show that a penalty or rejection no longer applies, the sampling and appeal costs will be the responsibility of the Owner.
- .5 If the new compaction standard verifies that any unit price reduction or rejection applies for that Lot, the costs of the appeal sampling and testing will be borne by the Contractor. If the results show that a penalty or rejection no longer applies, the sampling and appeal costs will be the responsibility of the Owner.
- .6 If the new average air void content result verifies that any unit price reduction applies for that Lot, the costs of the appeal testing will be borne by the Contractor. If the results show that a penalty or rejection no longer applies, the sampling and appeal costs will be the responsibility of the Owner.

.3 Core Density and Thickness Appeals

- .1 Core density and thickness appeals will only be considered if a case can be made that the stratified random sampling plan was biased or testing was in error.

## **5.0 END PRODUCT ACCEPTANCE OR REJECTION**

### **5.1 General**

- .1 The Contractor shall provide an end product conforming to the quality and tolerance requirements of this specification. Where no tolerances are specified, the standard of workmanship shall be in accordance with the accepted industry standards and this bylaw.
- .2 It is the paving contractor's responsibility to supply the appropriate materials and workmanship that will furnish a pavement that will last for the intended life span of the roadway. Satisfying the standards in this specification does not absolve the paving contractor's responsibility for a pavement that is prematurely aging or deteriorating as a result of substandard materials or poor workmanship
- .3 Acceptance of any Lot at full payment will occur if there are no obvious defects and the Lot mean results for asphalt content, pavement density, air voids and thickness meet or exceed the specified tolerances.
- .4 Unit price reductions will only be applied on the basis on full Quality Assurance testing in accordance with Table 4.4.4. Consecutive lot averages during a production period may be used to determine payment adjustments at the discretion of the Contract Administrator.
- .5 Any developer or representative who provides a letter of professional assurance for asphalt paving must satisfy the requirements in this specification. Quality control and quality assurance documentation must be available upon request. Companion samples taken as part of quality assurance testing must be available upon request by the City Representative. Any material or workmanship deficiencies are subject to either a payment adjustment to be paid to the City of Salmon Arm or removal and replacement. Payment adjustments will be determined by the guidelines in this specification. Removal and replacement will be at the discretion of the City of Salmon Arm. Assurances by the developer's engineer of record will be considered but not definitive in the acceptance of the final asphalt product.

## 5.2 Asphalt Content

- .1 For full payment, the Lot Mean Asphalt Content Must be within  $\pm 0.3\%$  of the approved Job Mix Formula value, as specified in Section 2.2.
- .2 Payment adjustment for asphalt content is as follows:

Asphalt Content Variation from JMF Value (%)	Payment Adjustment Factor
$\pm 0.30$ or less	1.00
$\pm 0.31$ to $\pm 0.50$	As per <b>Chart A</b>
Greater than $\pm 0.50$	Reject (Note 1)

Note 1: Subject to removal and replacement at the discretion of the Contract Administrator.

## 5.3 Pavement Compaction

- .1 For full payment, the Lot Mean Pavement Compaction must be equal to or greater than 97 % of the Lot Mean Marshall relative density.
- .2 Where an individual core has a core density less than 95 percent of the Marshall relative density then additional cores can be taken in the proximity of the defective core to determine the extent of the affected area. Additional coring shall be at the discretion of the Contract Administrator and the costs shall be borne by the Contractor. Possible scenarios where an individual core density is less than 95% of Marshall relative density are as follows:
  - .1 No additional coring is done and the core is included in the calculation of average core density for that lot.
  - .2 Additional coring in the proximity of the subject core that shows that the core is an anomaly. The core can then be removed from the payment adjustment calculation for that lot.
  - .3 Additional coring shows the extent of the affected paved area and is subsequently rejected.



- .3 Payment adjustment for pavement compaction is as follows:

<b>Pavement Compaction % of Marshall Relative Density</b>	<b>Payment Adjustment Factor</b>
97.0 or more	1.00
95.0 to 97.0	As per <b>Chart B</b>
Less than 95.0	Reject (Note 1)

Note 1: Subject to removal and replacement at the discretion of the Contract Administrator.

#### 5.4 Air Void Content

- .1 For full payment, the Lot Mean Air Voids must be within  $\pm 1.0$  % of the Job Mix Formula value as specified in Section 2.2.
- .2 Payment adjustment for air void content is as follows:

<b>Air Void Content % Variation from JMF Value</b>	<b>Payment Adjustment Factor</b>
Less than 1.0	1.00
1.0 to 2.0	As per <b>Chart C</b>
Greater than 2.0 (Lower Lifts)	0.8 (Note 1)
Greater than 2.0 (Upper Lifts)	0.6 (Note 1)

Note 1: Subject to removal and replacement at the discretion of the Contract Administrator.

#### 5.5 Thickness (New Construction and Top Lift Only)

- .1 Pavement of any type found to be deficient in thickness by more than 13.0 mm shall be removed and replaced by pavement of specified thickness, at the Contractor's expense.
- .2 The Lot Mean Thickness for any Lot will be determined on the basis of the acceptance cores described in Table 4.4.4. Core thickness shall be determined in accordance with ASTM D3549.
- .3 If the deficiency of any individual core exceeds 13 mm, additional cores may be extracted in the proximity to the location of the core of excessive deficiency, to identify the extremities of the pavement area subject to be removed and replaced. The Contractor shall pay for such additional coring.

- .4 For full payment, the Lot Mean Thickness must be equal to, or greater than, the specified thickness.
- .5 Payment adjustment for thickness is as follows:

Average Thickness Compared to Specified Thickness	Payment Adjustment Factor (Note 1)	
	Total Thickness (Single or Multiple Lifts)	Top Lift Thickness (Multiple Lifts)
Compliant or Greater	1.00	1.00
1mm to 13mm Deficient	As per <b>Chart D</b>	As per <b>Chart D</b>
More than 13mm Deficient	Reject (Note 2)	Reject (Note 2)

Note 1: A single Thickness Payment Adjustment Factor shall be applied, Total Thickness or Top Lift Thickness, whichever results in the greatest adjustment.

Note 2: Subject to removal and replacement at the discretion of the Contract Administrator.

### 5.6 Smoothness

- .1 The completed asphalt concrete surface shall be true to the dimensional and tolerance requirements of the specifications and drawings. Unless detailed otherwise in the contract documents, the tolerances in both profile and crown are:
  - .1 Base Course - 10 mm in 3.0 m
  - .2 Surface Course - 5 mm in 3.0 m
- .2 When deviations in excess of the above tolerances are found, the pavement surface shall be corrected by methods satisfactory to the Contract Administrator. Correction of defects shall be carried out until there are no deviations anywhere greater than the allowable tolerances.

### 5.7 Segregation

- .1 The finished surface shall have a uniform texture and be free of segregated areas. A segregated area is defined as an area of the pavement where the texture differs visually from the texture of the surrounding pavement.
- .2 All segregation will be evaluated by the Contract Administrator to determine repair requirements.

- .3 The severity of segregation will be rated as follows:
  - .1 Slight - The matrix of asphalt cement and fine aggregate is in place between the coarse aggregate particles, however there is more stone in comparison to the surrounding acceptable mix.
  - .2 Moderate - Significantly more stone than the surrounding mix, and exhibit a lack of surrounding matrix.
  - .3 Severe - Appears as an area of very stony mix, stone against stone, with very little or no matrix.
- .4 Segregated areas shall be repaired by the Contractor as directed by the Contract Administrator. The following methods of repair are identified.
  - .1 Slight - Squeegee asphalt to completely fill the surface voids.
  - .2 Moderate - slurry seal for full mat width.
  - .3 Severe - removal and replacement or overlay.
- .5 All repairs shall be regular in shape and finished using good workmanship practices to provide an appearance suitable to the Contract Administrator.
- .6 Any other methods of repair proposed by the Contractor will be subject to the approval of the Contract Administrator.
- .7 Repairs will be carried out by the Contractor at their expense.

## **6.0 MEASUREMENT AND PAYMENT**

### **6.1 Measurement**

- .1 Asphalt Concrete supplied will be measured in square metres or tonnes of material placed, as detailed in the Tender Form.
- .2 The Unit Price for Asphalt Concrete shall be full compensation for all materials, labour, tools, equipment and incidentals necessary to complete the work in accordance with these specifications.
- .3 The material shall be scaled and recorded by the Contractor on duplicate weight slips. Weight slips must be supplied at the time of delivery and a copy supplied to the Contract Administrator.
- .4 The weight scale shall be inspected and certified by Weights and Measures Inspection Services of the Federal Department of Consumer and Corporate Affairs, at the Contractors' expense and as often as the Contract Administrator may direct.

**6.2 Payment Adjustment**

- .1 The Unit Price applicable to each Lot quantity of asphalt concrete will be calculated as follows:

$$\text{LOT UNIT PRICE} = \text{CONTRACT UNIT PRICE} \times \text{PA}_{\text{AC}} \times \text{PA}_{\text{COM}} \times \text{PA}_{\text{AV}} \times \text{PA}_{\text{T}}$$

Where:

$\text{PA}_{\text{AC}}$  = Asphalt Content Payment Adjustment

$\text{PA}_{\text{COM}}$  = Compaction Payment Adjustment

$\text{PA}_{\text{AV}}$  = Air Void Payment Adjustment

$\text{PA}_{\text{T}}$  = Thickness Payment Adjustment

**Table 4.2.4 – Pre-production Quality Control Minimum Requirements**

Asphalt Cement Certification	-	Once per year or for change in supplier.
Aggregate Physical Properties	-	Once per year, or for change in source.
Crushed Coarse Aggregate Gradation Analysis and Fracture Content	ASTM C136 ASTM D5821	One for every 1000 tonne of each class of material processed into stockpile, or one analysis for each material every production day when production rate is less than 1000 tonne.
Manufactured Sand Aggregate Gradation	ASTM C136 ASTM C117	
Natural Fine Aggregate Gradation	ASTM C136 ASTM C117	
Blend Sand Aggregate Gradation	ASTM C136 ASTM C117	
Reclaimed Asphalt Pavement (RAP) Asphalt Content and Extracted Aggregate Gradation	ASTM D2172 ASTM C136 ASTM C117	One for each 1000 tonne delivered to stockpile or one for each location when delivery rate is less than 1000 tonne.
Trial Mix Design by Marshall Method	Asphalt Institute MS-2	One per mix type every production year, or as required for a change in asphalt cement supply, aggregate gradation or aggregate source. See Note 1.
Plant Calibration	-	As required

**Table 4.2.5 – Post Production Quality Control Minimum Requirements**

Hot Mix Asphalt Analysis (including Asphalt Content, Aggregate Gradation, Marshall Bulk Relative Density and Void Properties)	ASTM D6307 ASTM C117 ASTM C136 ASTM D3203	One for every 500 tonne of each mix type supplied under this specification. See Note 1.
Quality Control Charts (including 2 test running average for Binder Content, Aggregate Gradation, Marshall Bulk Relative Density and Void Properties).	-	For each hot mix analysis. Test results and updated 2 test running average to be submitted to the Contract Administrator as they become available. See Note 2.
Hot Mix Asphalt Temperature	-	Minimum frequency not specified.
Cold Feed Aggregate Analysis	ASTM C136 ASTM C117	Minimum frequency not specified.
Maximum Relative Density of Hot Mix Asphalt	ASTM D2041	Minimum frequency not specified.
Compaction Monitoring (Core or Nuclear Density)	ASTM D2726 ASTM D2950	Minimum frequency not specified. See Note 3.

Note 1: Where an individual test indicates non-compliance, another test shall be initiated immediately.

Note 2: In instances where the contractor is paving on consecutive days, asphalt content and air voids shall be submitted to the Contract Administrator within 24hrs of sampling.

Note 3: Coring is subject to approval by the Contract Administrator.

**Table 4.4.4 – Quality Assurance Minimum Requirements**

Hot Mix Asphalt Analysis (including Binder Content, Aggregate Gradation, Marshall Bulk Relative Density, Maximum Relative Density, Marshall Stability and Flow and Void Properties)	ASTM D6307 ASTM C117 ASTM C136 ASTM D3203, ASTM D6927, ASTM D2041	For each mix type one test per lot or one test per 4.0 hrs of continuous paving, whichever is greater. See Note 1.
Compaction Testing (Core Density) and Thickness Determination	ASTM D2726 ASTM D3549	For each mix type three tests per complete lot. See Note 2.
Hot Mix Asphalt Temperature	-	No minimum frequency.

Note 1: The Contract Administrator may, at their discretion, acquire the minimum number of mix samples, but reduce the number of tests to a minimum of one per lot. Should non-compliance be indicated by the sample(s) tested, the Contract Administrator reserves the option to test the remaining samples. The lot boundaries should be adjusted so the consecutive test can be a part of the same lot.

Note 2: For partial lots where total paving is greater than 1500 m<sup>2</sup> one test per 500 m<sup>2</sup> should be completed. When total paving area is less than 1500 m<sup>2</sup> a minimum of 3 tests should be completed. The number of tests required for small paving areas less than 500 m<sup>2</sup> will be at the discretion of the contract administrator, it is anticipated that at least 2 cores would be taken for payment adjustment purposes.

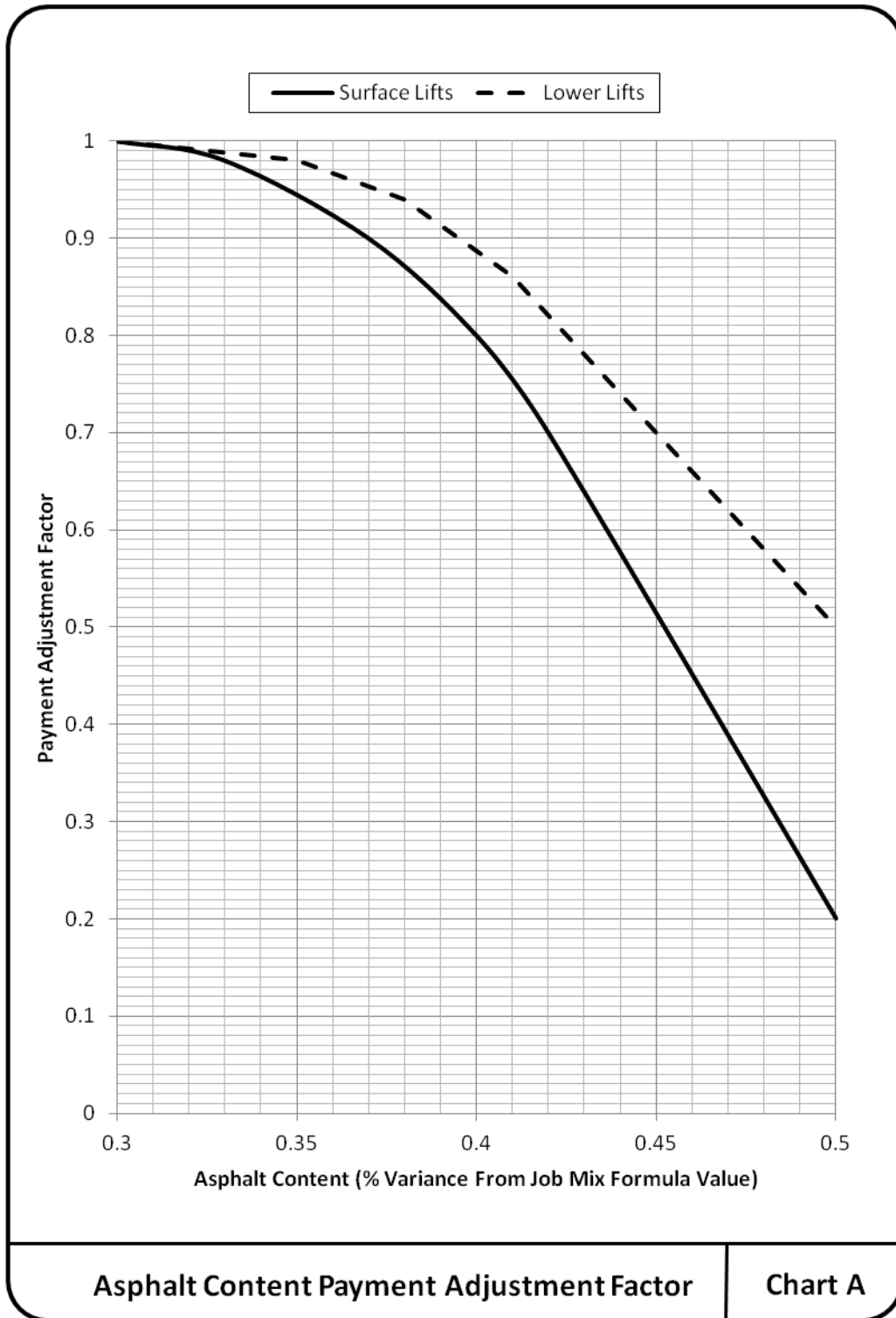

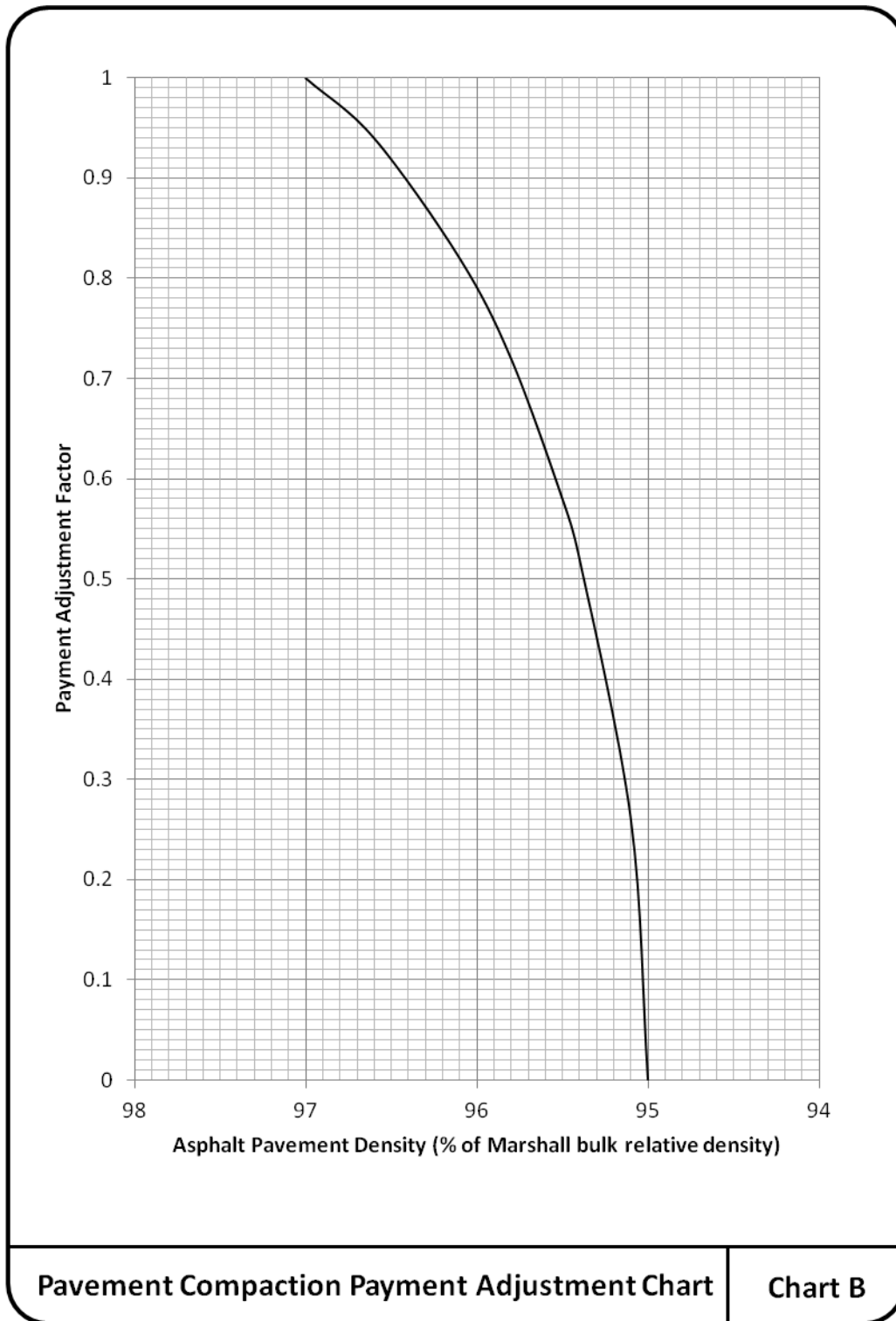



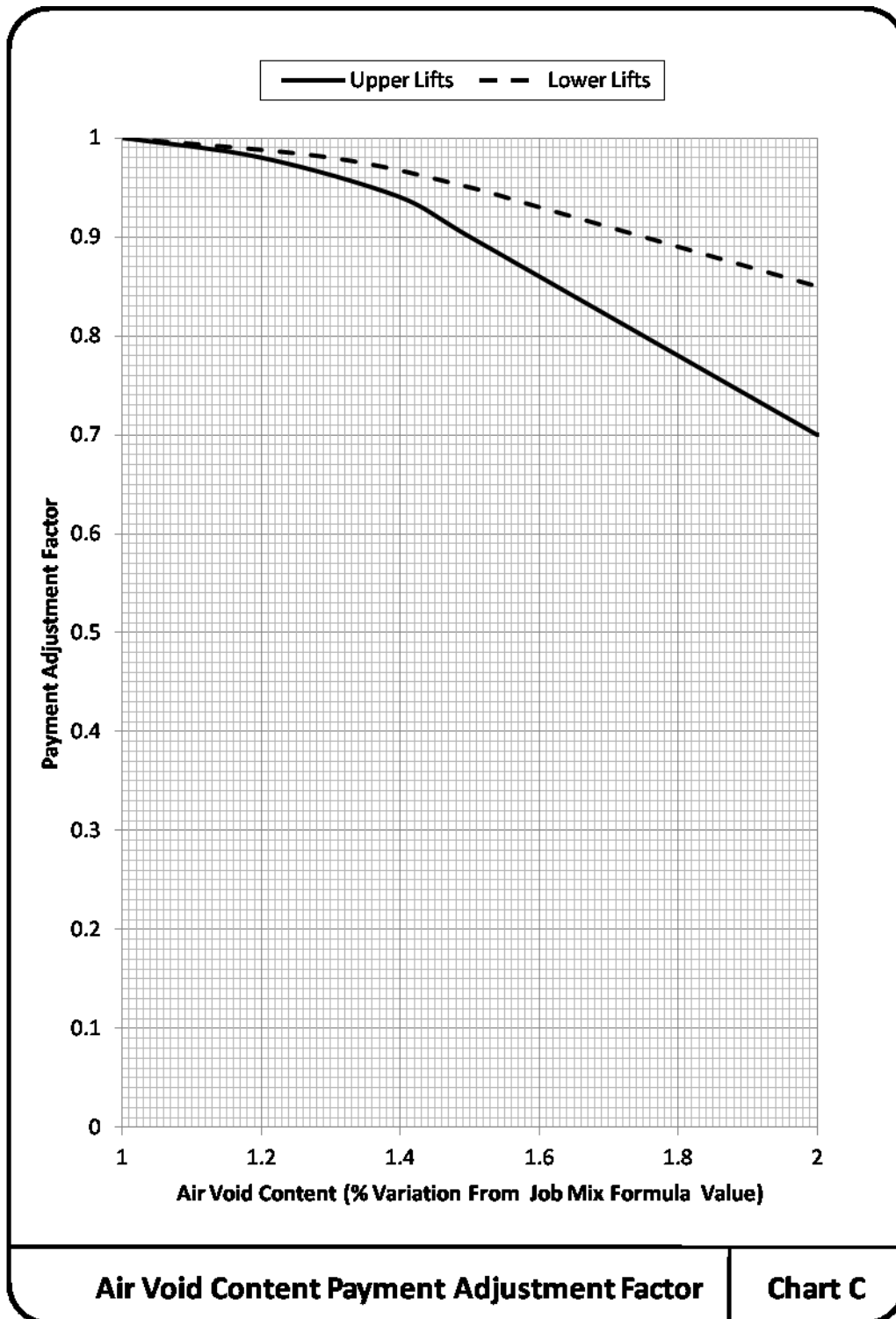

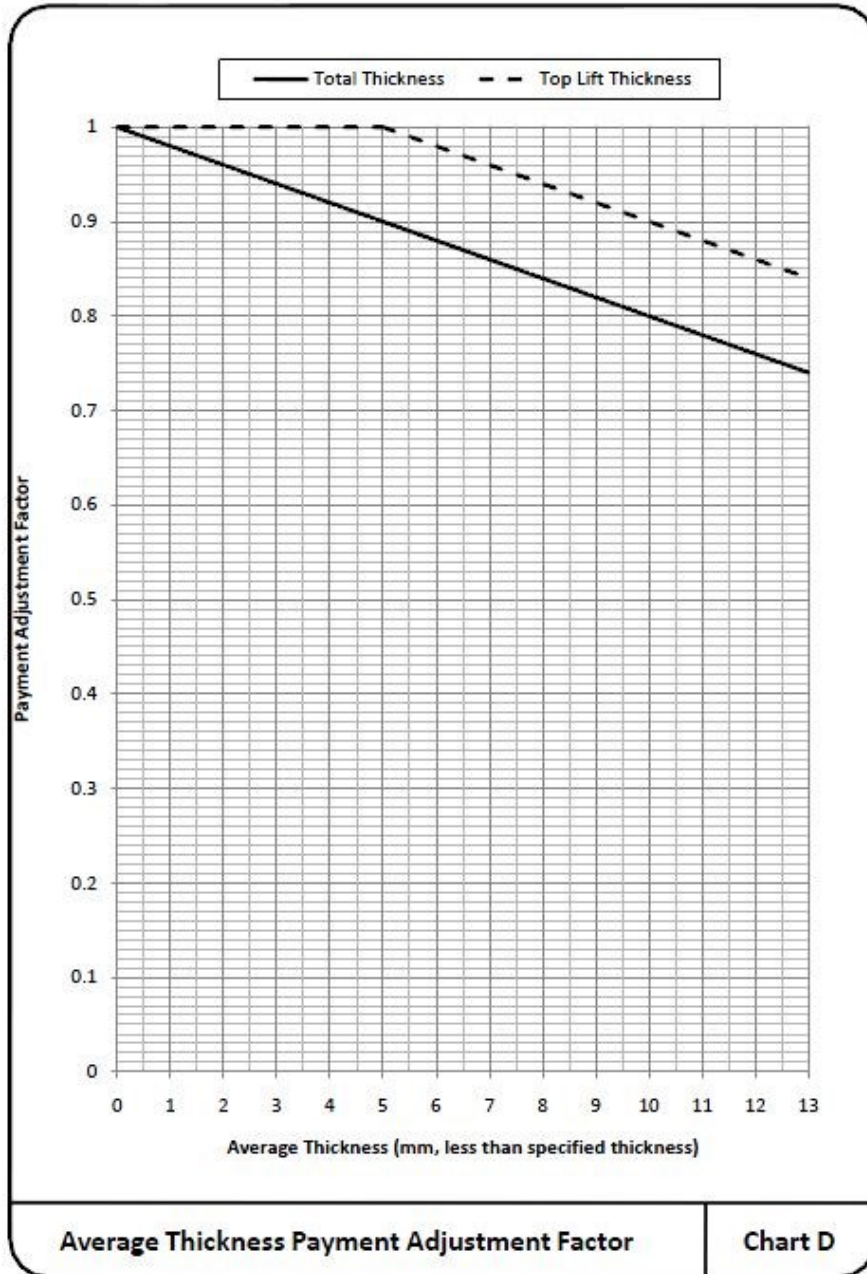

**1.7 Inspection and Testing**

Add: .2 Visual Inspection: Prior to installation, all pavers shall be sound and free from defects that can interfere with proper placing of the pavers or impair the serviceability of the pavement. Minor cracks incidental to the usual methods of manufacture or minor chipping resulting from customary methods of handling in shipment and delivery, shall not be deemed grounds for rejection.

**2.1 Materials**

Replace: .4 Granular laying course:

.1 Bedding Sand shall consist of hard, durable crushed stone particles, free from clay lumps, cementation, organic material, frozen material and other deleterious materials and shall comply with ASTM C33 or CSA CAN/CSA A23.1.1-M90 with the following grading limits:

<b>CAN/CSA-A23.1-M90</b>		<b>ASTM C33</b>	
<b>Sieve Size</b>	<b>% Passing</b>	<b>Sieve Size</b>	<b>% Passing</b>
100 mm	100	3/8 in.	100
5 mm	95 – 100	4	95 – 100
2.5 mm	80 – 100	8	80 – 100
1.25 mm	50 – 90	16	50 – 85
630 µm	25 – 65	30	25 – 60
315 µm	10 – 35	50	10 – 30
160 µm	2 – 10	100	2 – 10

- .2 Jointing sand shall be free of soluble salts or contaminants that can contribute to efflorescence and shall comply with ASTM C144, CSA A82.56M-1976 – Aggregate for Masonry Mortar with the following grading limits.

CAN/CSA-A23.1-M90		ASTM C144	
Sieve Size	% Passing	Sieve Size	% Passing
5 mm	100	4	100
2.5 mm	95 – 100	8	95 – 100
1.25 mm	60 – 100	16	70 – 100
600 µm	35 – 80	30	40 – 75
315 µm	15 – 50	50	10 – 35
160 µm	2 – 15	100	2 – 15

Replace: .5 Unit Pavers:

- .1 Concrete Pavers shall be 225 mm x 112.5 (8-7/8"x 4-7/16") face dimension x 60 mm (2-3/8") thickness, complete with spacer ribs. Minimum cement content of 325 kg./m<sup>3</sup>. Coloured pavers with min. 10 kg./m<sup>3</sup> of pigment. Allow 3 colours, 40% red; 30% salmon; 30% grey. Final selection by architect from manufacturer's full range of colours.
- .2 Physical Requirements
- .1 Comprehensive Strength: At the time of delivery to the work site, the average compressive strength of the test samples of pavers shall not be less than 60 Mpa (8500 psi) with no individual unit less than 55 Mpa (8,000 psi) and the average compressive strength of Normal pavers shall not be less than 55 Mpa (8,000 psi) with no individual unit less than 50 Mpa (7,200). Sample and test units in accordance with ATM Method C140.

- .2 Absorption: The average water absorption with ATM Method C140, of the test samples shall not be greater than 4.5% with no individual pave greater than 6% for DURA-FINISH pavers and not greater than 5% with no individual paver greater than 7% for Normal pavers.
- .3 Resistance to Freezing and Thawing: Pavers shall have a dry mass loss not more than 0.5% and Normal pavers not more than 1% dry mass loss for any individual paver when subjected to 50 cycles of freezing and thawing in accordance with Section 8 of ASTM Method C67.
- .4 Abrasion Resistance: Pavers shall have a volume loss of less than 6 cm<sup>3</sup> per 50m<sup>2</sup> (4 cu.in. per 8 sq. in.) and the average thickness loss shall not be more than 2 mm (5/64"), when tested in accordance with ASTM Method C418. Normal pavers shall have a volume loss of less than 15 cm<sup>3</sup> per 50 m<sup>2</sup> (1 cu. In per 8 sq. in.) and the thickness loss shall not be more than 3 mm (1/8") when tested in accordance with ASTM Method C418.
- .5 Tolerance in Dimensions: Length or widths of units shall not differ by more than ±1,5 nn (± 1/16") from Westcon's stated manufacturing dimension. Thickness of pavers shall not vary by more than ± 3mm (± 1/8") from Westcon's stated dimension.

### 3.4 Granular Laying Course

- Add:
- .2 The bedding sand shall be spread in a uniform layer. Under no circumstances shall the bedding sand layer exceed 40 mm (1-1/2") following compaction.
  - .3 The sand shall be maintained at a uniform density. Screeded sand left overnight subjected to rain shall be rechecked for level and raked and re-screeded where necessary.
  - .4 Do not allow any traffic on the bedding sand prior to paver installation.
  - .5 Bedding sand shall not be used for correcting out of tolerance base.

### 3.5 Unit Paving

Replace: .2 Install unit paving true to grade, in location, layout and pattern as shown on Contract Drawings. Surface levels of the completed pavement at drainage outlets and curbs shall be left 10mm (3/8") high to ensure positive drainage.

Replace: .3 Where required, cut units accurately without damaging edges. No pieces shall be smaller than ¼ of a full paver.

- 1 GENERAL** Section 32 91 22S refers to those portions of the work that are unique to the use of soil cells for the planting of trees and landscaping in pedestrian and vehicular areas. This section must be referenced to and interpreted simultaneously with all other sections pertinent to the works described herein.
- 1.1 Related Work**
- |     |   |                   |
|-----|---|-------------------|
| .1  | Concrete Walks, Curbs and Gutters             | Section 03 30 20  |
| .2  | Cast-in-Place Concrete                        | Section 03 30 53  |
| .3  | Aggregates and Granular Materials             | Section 31 05 17  |
| .4  | Excavation, Trenching and Backfilling         | Section 31 23 01  |
| .5  | Roadway Excavation, Embankment and Compaction | Section 31 24 13  |
| .6  | Geosynthetics                                 | Section 31 32 19  |
| .7  | Granular Base                                 | Section 32 11 23  |
| .8  | Irrigation System                             | Section 32 94 01S |
| .9  | Topsoil and Finish Grading                    | Section 32 91 21  |
| .10 | Planting of Trees, Shrubs and Ground Covers   | Section 32 93 01  |
- 1.2 Site Conditions**
- |    |   |
|----|---|
| .1 | Inspect all areas to receive soil cells prior to placement.   |
| .2 | Before proceeding with work check and verify dimensions, quantities, grade elevations, drainage, compaction and contamination.  |
| .3 | Report defects in dimensions, quantities, grade elevations, drainage, compaction and contamination to Contract Administrator immediately and make good to satisfaction of Contract Administrator prior to construction of soil cell system. |
- 1.3 Delivery, Storage and Handling**
- |    |   |
|----|---|
| .1 | Deliver packaged materials in original, unopened containers showing weight, certified analysis and name and address of manufacturer.  |
| .2 | Do not handle, deliver or place bulk materials in frozen, wet or muddy conditions.  |
| .3 | Deliver materials to site at or near optimum compaction moisture content.   |
| .4 | Protect excavation from freezing conditions, accumulation of water and contamination until placement of soil cells, growing medium, geotextile and root barrier. Maintain protection of excavation and placed material until installation of hard surfaced roadway or pedestrian surface above. |
| .5 | Growing medium, granular base and backfill that is excessively wet, segregated or contaminated will be rejected. Remove rejected material from site and replace with approved material at Contractor's expense.   |
- 1.4 Layout and Elevation Control**
- |    |   |
|----|---|
| .1 | Provide layout and elevation control during installation of soil cells. Utilize grade stakes, benchmarks, surveying equipment and other |
|----|---|

means and methods to ensure that layout and elevations conform to layout and elevations shown on Contract Drawings

- 1.5 Scheduling**
  - .1 Schedule installation of soil cells after all affecting walls, curbs, footings and utility work in the area have been installed.
  - .2 Coordinate schedule with scheduling of other trades on site.
- 1.6 Measurement and Payment**
  - .1 Payment for soil cells will be made separately for each vertical column of soil cell assembly, and includes all soil cell components, growing medium, site preparation, placement, geogrid and geotextile, protection of work and incidentals. Payment will be made separately for assemblies comprised of one, two or three layers of soil cell frames.
  - .2 Payment for excavation, backfilling and embankment of soil cells will be made under Section 31 23 01 - Excavating, Trenching and Backfilling or Section 31 24 13 - Roadway Excavation, Embankment and Compaction, as provided in the Schedule of Quantities and Unit Prices.
  - .3 Payment for placement and compaction of granular base will be made under Section 32 11 23 - Granular Base, as provided in the Schedule of Quantities and Unit Prices.
  - .4 Payment for pedestrian or vehicle surfaces above soil cells will be made under separate sections as appropriate.
  - .5 Payment for tree planting, associated non-soil cell growing medium, root barrier, tree grates and concrete surrounds will be made under separate sections as appropriate.
- 1.7 Inspection and Testing**
  - .1 Refer to General Conditions, Clause 4.12, Inspections and Testing.
  - .2 Refer to Section 32 91 21 - Topsoil and Finish Grading - 1.3 and 1.5.
- 2.0 PRODUCTS**
- 2.1 Soil Cell**
  - .1 Soil cell to be fiberglass-reinforced polypropylene structure, or other materials, designed to support sidewalk loads, designed to be filled with growing medium for the purpose of growing tree roots, and for rainwater filtration, detention and retention.
  - .2 Acceptable soil cell systems are listed in the approved materials list.
- 2.2 Anchor Spike**
  - .1 Galvanized steel spike with spiral twist, 8mm diameter and 250mm length.
- 2.3 Drainage Pipe**
  - .1 Drainage pipe to be perforated drain pipe per Section 33 40 01 - Storm Sewers - 2.7, as specified on Drawings.
  - .2 Fittings to be compatible with specified pipe and by same manufacturer.
  - .3 PVC pipe solvent and primer combinations shall be as recommended by manufacturer and suitable for use with specified materials and application.



- 2.4 Geogrid** .1 Geogrid to be high molecular weight high tenacity polyester multifilament yarns woven in tension and polymer-coated, with the following ASTM D 6637 mechanical properties:
- .1 Tensile strength: 29.2 kN/m
  - .2 Creep reduced strength: 18.5 kN/m
  - .3 Long term allowable design load: 18.5 kN/m
  - .4 Grid aperture size (machine direction): 22.2mm
  - .5 Grid aperture size: 25.4mm
  - .6 Mass /unit area (ASTM D 5261): 254.3 g/m<sup>2</sup>
- 2.5 Geotextile** .1 Geotextile to be non woven polypropylene fabric, with the following properties:
- .1 Grab tensile strength: 167.8 kg
  - .2 Grab tensile elongation: 50%
  - .3 Mullen burst strength: 2,620 kPa
  - .4 Puncture strength: 58.97 kg
  - .5 Apparent opening size: US sieve 80 (0.180mm)
  - .6 Water flow rate: 3,870.8 l/min/m<sup>2</sup>
  - .7 Minimum roll width: 3600 mm
- 2.6 Granular Base** .1 Granular base and subbase to be as shown on Contract Drawings and to conform to Section 32 11 23 - Granular Base.
- 2.7 Backfill** .1 Backfill material adjacent to soil cells to be as shown on Contract Drawings.
- 2.8 Growing Medium** .1 Growing medium to be as shown on Contract Drawings and to conform to Section 32 91 21– Topsoil and Finish Grading.
- 3.0 EXECUTION**
- 3.1 Soil Cell Frame** .1 Confirm that granular base meets compaction requirements of 95% of maximum dry density in accordance with ASTM D698 Standard Proctor method prior to placement of soil cell frame units. Grade sub-base surface on a plane parallel to the proposed finish grade above.
- .2 Identify tree openings, utility routes and edges of hard surfaces above soil cells on granular base using spiked string and/or spray paint.
  - .3 Confirm that width and length of excavation are a minimum of 150mm beyond the edges of the Soil Cells. Layout location of all drain lines. Do not locate drain lines within 150mm of any Soil Cell post. Provide field engineering when drain lines are being installed to assure that the slope on all drains is 1% minimum towards intended outfalls. Place frame units by hand.
  - .4 Place first layer of frame units on prepared and approved granular base and geotextile. Work away from tree and utility openings. Place frame units no less than 25mm apart and no more than 75mm apart.

- .5 Verify that horizontal and vertical position of frame units are consistent with required locations and dimensions of tree and utility openings, paving edges, surfaces and other structures to be constructed above soil cells. Report conflicts to Contract Administrator and make adjustments as necessary.
- .6 Ensure that each frame unit sits firmly on granular base. Ensure frames do not rock or bend over any stone or other obstruction and do not bend into dips in base.
- .7 Check each frame unit for damage prior to placing in excavation. Do not use frame units that are cracked or chipped
- .8 Secure soil cell to granular base with four anchor spikes driven through moulded holes in base of frame unit
- .9 For applications where soil cells are installed over waterproofed structures, develop a spacing system consistent with requirements of waterproofing system and do not use anchor spikes that will come within 150mm of any waterproofing material. Submit shop drawing of spacing and anchoring system for approval by Contract Administrator.
- .10 Do not walk on frame units.
- .11 Install next layer of frame units on top of previous layer. Build layers as stacks of frame units set one directly over the other. Do not set frame unit half on one unit below and half on another unit.
- .12 Register each upper frame unit on top of lower frame unit post. Ensure contact points are free of dirt, mud and debris prior to placement. Ensure each upper unit is solidly seated on unit below. Rotate each frame registration arrow in the opposite direction from frame unit below to ensure connector tabs firmly connect.
- .13 Install no more than two layers of frame units before installation of growing medium and backfill.

**3.2 Modified Soil Cell Frame**

- .1 Install modified frame unit on top of frame unit prior to installation of growing medium and backfill.
- .2 Modified frame unit is required only during installation and compaction of growing medium and backfill.
- .3 Do not walk on modified frame units.
- .4 Remove modified frame unit prior to installation of deck unit and as installation of growing medium and backfill progresses across soil cell framework.
- .5 Remove modified frame unit prior to installation of deck unit and as installation of growing medium and backfill progresses across soil cell framework.
- .6 Place and remove modified frame units by hand.

- |  |  |
|--|--|
| <b>3.3 Geogrid</b>                     | <ul style="list-style-type: none"> <li>.1 Install geogrid curtain prior to installation of growing medium and backfill.</li> <li>.2 Geogrid curtain is required between edge of soil cell and any backfill or granular base beyond extent of soil cell framework that will support pedestrian or vehicular paving.</li> <li>.3 Install geogrid curtain where required. Do not install geogrid curtain between edge of soil cell and any planting area or tree opening adjacent to soil cell.</li> <li>.4 Pre-cut geogrid to allow for 150mm minimum underlap below backfill, and 300mm minimum overlap above soil cell deck.</li> <li>.5 Where soil cell layout causes a change of direction in plane of geogrid, slice top and bottom flaps of geogrid and fold so it lies flat on top of soil cell deck and granular base course along both planes.</li> <li>.6 Provide 300mm minimum overlap between different sheets of geogrid.</li> <li>.7 Secure geogrid to frame units and deck units with 4.5mm x 300mm plastic zip ties in locations recommended by manufacturer.</li> <li>.8 After deck unit is secured in place fold 300mm overlap of geogrid over top of unit.</li> </ul>   |
| <b>3.4 Growing Medium and Backfill</b> | <ul style="list-style-type: none"> <li>.1 Install root barrier as shown on Contract Drawings. Protect root barrier from damage and displacement during installation of growing medium and backfill.</li> <li>.2 Install growing medium and backfill as indicated on Contract Drawings. The process of installation requires that these two materials be installed and compacted together in alternating lifts to achieve correct compaction relationships between the materials.</li> <li>.3 Place growing medium in soil cell framework and spread by hand or hand tool through each soil cell in a maximum 200mm lift. Work soil under horizontal beams of soil cell frame and utility conduit to eliminate air pockets there. Ensure equipment bucket does not contact soil cell framework. Hold plywood sheet against geogrid during placement and compaction of growing medium to protect geogrid and maintain consistent separation of materials.</li> <li>.4 Finalize installation of utility conduit, drainage pipes and irrigation where shown on Contract Drawings.</li> <li>.5 Compact growing medium lift by stepping on entire exposed surface of growing medium. Do not step on frame units. Ensure there is a minimum of 250mm of growing medium over horizontal beams of frame units before beginning compaction. Leave top 50mm of frame unit exposed above growing medium to allow placement of next layer of frame units.</li> <li>.6 Compact growing medium to 85% of standard proctor density. Remove growing medium that is over compacted and reinstall.</li> </ul> |

- .7 Place backfill to 95% of maximum dry density in space between geogrid and sides of excavation and spread by hand adjacent to soil cell framework to provide maximum 200mm lift. Ensure geogrid under lap lays flat under backfill. Ensure equipment bucket does not contact soil cell framework. Hold plywood sheet against geogrid during placement and compaction of backfill to protect geogrid and maintain consistent separation of materials. Do not place backfill material in tree or planting bed opening.
- .8 Compact backfill per Contract Documents. Ensure compaction equipment does not contact soil cell frame or deck.
- .9 Repeat placement and compaction of growing medium and backfill in lifts to top of topmost frame unit. Finish grade of growing medium to be 25mm below bottom of deck unit, except as indicated otherwise on Contract Drawings.
- .10 Do not place final lift of backfill until adjacent deck unit is secured in place. Then install and compact backfill flush with soil cell deck. Ensure compaction equipment does not contact deck unit.
- .11 Maintain modified frame unit in place until installation of deck unit.

**3.5 Geotextile**

- .1 Supply and install geotextile under soil cell system as shown on Contract Drawings and per Section –31 32 19 - Geosynthetics.
- .2 Supply and install geotextile on soil cell deck as shown on Contract Drawings and per Section 31 32 19 - Geosynthetics
- .3 Place geotextile over top of soil cell deck and where indicated on Drawings.
- .4 Extend geotextile minimum 450mm beyond outside edge of excavation. Overlap geotextile joints minimum 450mm. Cut geotextile to provide minimum 200mm overlap of tree, planting and utility openings.
- .5 Repair cut or damaged geotextile with a second piece of geotextile prior to placement of granular base. Overlap edges of cut or damaged area with second piece by a minimum of 300mm.

**3.6 Granular Base**

- .1 Supply and install granular sub-base course under soil cell system as shown on Contract Drawings and as specified in Section 32 11 23 - Granular Base.
- .2 Supply and install aggregate base course above soil cell system as shown on Contract Drawings and as specified in Section 32 11 23 - Granular Base.
- .3 Maximum tolerance for deviations in finished surface of granular base for soil cell system is 6mm over a 1200mm distance. Adjust granular base under each frame unit to provide a continuous solid base of support to required grade elevation.
- .4 Install granular base course on geotextile immediately after installation of geotextile.

- .5 Place granular base on soil cell system from one side of soil cell deck to other, to ensure geotextile and granular base conforms to cell deck contours.
  - .6 Do not place or spread granular base in several positions at same time.
  - .7 Load granular base onto soil cell system from equipment located outside limits of soil cell excavated area. Do not drive vehicles or operate equipment directly on top of soil cell deck, geotextile or granular base. Do not drive vehicles or operate equipment greater than 450kg directly on granular base over soil cell deck.
  - .8 Spread granular base on soil cell system using hand tools or by light use of equipment bucket.
  - .9 Compact granular base in lifts not to exceed 150mm, to 95% of maximum dry density. Compact granular base on top of soil cell system using walk behind type vibratory plate tamper, vibratory roller or jumping compacter having a maximum weight of 450kg.
  - .10 For alternate method of placing and compacting granular base on top of soil cell system (e.g. for large area, small area, area of difficult access) submit shop drawing of proposed equipment and procedure to Contract Administration for approval.
- 3.7 Protection of Work**
- .1 Protect soil cell system, geotextile and granular base from vehicles, equipment, other materials and excessive moisture.
  - .2 Use temporary fencing or hoarding to keep vehicles and equipment away off soil cell area until final surface materials are placed.
- 3.8 Clean Up**
- .1 Dispose of surplus materials and all construction debris off site.

- |                              |    |   |                     |
|------------------------------|----|---|---------------------|
| <b>1.0 GENERAL</b>           | .1 | Section 32 94 01S refers to those portions of the work that are unique to the complete installation of a fully automatic underground irrigation system, including all necessary preparatory work and all electrical, wiring and plumbing connections, and maintenance work during the guarantee period. This section must be referenced and interpreted simultaneously with all other sections pertinent to the works described herein. |                     |
| <b>1.1 Related Work</b>      | .1 | Project Record Documents  | Section 01 33<br>01 |
|                              | .2 | Cast-in-Place Concrete  | Section 03 30 53    |
|                              | .3 | Precast Concrete  | Section 03 40<br>01 |
|                              | .4 | Aggregates and Granular Materials   | Section 31 05<br>17 |
|                              | .5 | Topsoil and Finish Grading  | Section 32 91<br>21 |
|                              | .6 | Hydraulic Seeding   | Section 32 92 19    |
|                              | .7 | Seeding   | Section 32 92 20    |
|                              | .8 | Sodding   | Section 32 92 23    |
|                              | .9 | Planting of Trees, Shrubs<br>and Ground Covers  | Section 32 93 01    |
| <b>1.2 References</b>        | .1 | The abbreviated standard specifications for testing, materials, fabrication and supply, referred herein, are fully described in References – Section 01 42 00.  |                     |
| <b>1.3 Codes and Permits</b> | .1 | Perform all work of this section in strict accordance with all municipal, provincial, or federal guidelines, regulations, and codes. Requirements of these specifications not conflicting therewith, exceeding code requirements govern.  |                     |
|                              | .2 | Be responsible for obtaining all necessary permits and approvals required to undertake and complete the work. Include costs for required permits and approvals in tendered prices.  |                     |
| <b>1.4 Quality Assurance</b> | .1 | Be a member in good standing of one of the following organizations:<br>.1 Irrigation Industry Association of British Columbia (IIABC)<br>.2 The Irrigation Association (IA)<br>Provide documented proof of 5 years of industry experience, good standing membership in one of the above associations within 5 days of receipt of Notice to Proceed.   |                     |

- .2 Be certified, or hire subcontractor who is certified, as a Field Safety Representative – Class LO, Low Energy Systems and registered with the British Columbia Safety Authority as an Electrical Contractor. Provide documented proof of same within 5 days of receipt of Notice to Proceed.
  - .3 If the design involves HPDE, be certified in Plastic Pipe Fusion by the British Columbia Institute of Technology or an approved equivalent to fuse and install High Density Polyethylene Pipe. Provide documented proof of same within 5 days of receipt of Notice to Proceed.
  - .4 All electrical components or products specified or used in construction of the proposed irrigation system must be CSA approved and installed in accordance with all local, provincial, and national electrical codes.
  - .5 Install all irrigation components per manufacturer’s recommendations, instructions and specifications. If unsure on how to install or use a specific product consult manufacturer to ensure proper installation and operation.
  - .6 All materials to be new and without flaws.
  - .7 All equipment specified and installed from various manufacturers to be compatible with existing equipment and other products specified for the irrigation system.
  - .8 The completed system to efficiently and uniformly irrigate all areas and perform as required by these specifications.
- 1.5 Scheduling and Shop Drawings**
- .1 Ensure that sequencing of irrigation work is carried out in coordination with work of other trades and that sleeves, wire, pipes, valves and other equipment are installed when appropriate.
  - .2 Plan, schedule and execute work to ensure a supply of water is available for landscape establishment and maintenance purposes at the appropriate time, in adequate amounts, and operating at design pressures to ensure satisfactory irrigation of all landscaped areas.
- 1.6 Substitutions**
- .1 Where materials are specified by brand name and model number, such specifications will be deemed to facilitate a description of the materials and material quality and establish a standard for performance and quality.
  - .2 Purchase or installation of materials that are not specified will not be paid for unless:
    - .1 The materials have been reviewed and approved by Contract Administrator and City of Salmon Arm as an Approved Equal as per Section 7.0, Instructions to Tenderers, or

- .2 The materials have been reviewed and approved by Contract Administrator and City of Salmon Arm as a Change Order, per Section 7.3 of the General Conditions
  - .3 Installation of materials that are not specified or are not an Approved Equal to be removed and replaced with the specified material at Contractor's expense.
  - .4 Shop Drawings of irrigation system are required for any and all aspects of irrigation system not included in the Drawings. This includes but is not limited to:
    - .1 Revisions to irrigation system design not previously addressed in Contract Documents, including revisions to irrigation system design which markedly alter the original design, as determined by the City Engineer.
    - .2 Tasks identified in project specifications as requiring a Shop Drawing
  - .5 A revised Irrigation Design Report shall be required in tandem with Shop Drawings for revisions that markedly alter the original design, as determined by the City Engineer
  - .6 Submit Shop Drawing and revised Irrigation Design Report to Contract Administrator and City of Salmon Arm, for review, comment and approval or rejection.
- 1.7 Irrigation Record Drawings**
- .1 Further to Schedule 3, maintain accurate scaled records of installed irrigation system and its components on a marked-up set of Contract Drawings on a daily basis during construction. Show all deviations from Contract Drawings. Make marked-up Contract Drawings available to Contract Administrator upon request.
  - .2 Retain a qualified survey instrument operator to record exact location of all irrigation components as installed, including but not limited to:
    - .1 All irrigation surface components: e.g. sprinklers, valve locations, grounding point, controller components, wire splice boxes, valve boxes, vaults
    - .2 All irrigation sub-surface components: e.g mainlines, laterals, pipe tees, ells, thrust blocks, pipe size changes, grounding components, sleeve ends
  - .3 Prepare surveyed Record Drawings. Clearly and legibly show all components of the irrigation system as installed. Identify each zone numerically, complete with precipitation rate and USgpm per zone. Prepare Record Drawings in digital (AutoCAD 2008 \*.dwg and Adobe \*.pdf) and hard copy formats



- |                             |    |  |
|-----------------------------|----|--|
| <b>1.8 Operating Manual</b> | .1 | <p>Prepare a complete Operating Manual for installed irrigation system. Content of Operating Manual to include:</p> <ul style="list-style-type: none"> <li>.1 Irrigation Design Report</li> <li>.2 Equipment operating instructions</li> <li>.3 Maintenance instructions including winterization and spring start up procedures</li> <li>.4 Product literature</li> <li>.5 Parts lists</li> <li>.6 Irrigation watering schedule</li> <li>.7 Two (2) sets of all keys and specialized tools or equipment required for commissioning, operation or maintenance of irrigation system</li> <li>.8 Signed copies of irrigation inspection reports and test results</li> <li>.9 Copies of plumbing permit, electrical permit and low voltage certification</li> <li>.10 Product warranty documentation for all controllers, meters, backflow prevention devices, valves, filters, sensors, electronic components and related irrigation components. Date the warranties with the date of Substantial Performance</li> <li>.11 Written guarantee</li> </ul> |
| <b>1.9 Submittals</b>       | .1 | <p>Submit complete set of Record Drawings to Contract Administrator prior to issuance of Certificate of Substantial Performance. Submit digital and hard copy Record Drawings in full size (22x34”) and reduced (11x17”) sizes, including one (1) laminated, 11”x17” copy of Record Drawings in controller cabinet.</p>  |
|                             | .2 | <p>Submit complete Operating Manual to Contract Administrator prior to issuance of Certificate of Substantial Performance.</p>   |

**1.10 Measurement for Payment**

- .1 Supply and installation of water service will be measured as a lump sum. The work includes:
  - .1 Permits and fees
  - .2 Supply, installation, testing and adjustment of the connection to water source and booster pump if required
  - .3 Master valve
  - .4 Water meter
  - .5 Flow sensor
  - .6 Backflow prevention device
  - .7 Blowout assembly
  - .8 Pressure reducing valve
  - .9 Filters
  - .10 Vaults, valve boxes & lids
  - .11 Fittings
  - .12 Excavation, trenching, sleeves, backfill and restoration
  - .13 All incidentals necessary for the proper installation and operation of a complete water service to the irrigation system
- .2 Supply and installation of irrigation control system will be measured as a lump sum. The work includes
  - .1 Permits & fees
  - .2 Supply, installation, testing, programming, and adjustment of irrigation system controller
  - .3 Electrical conduits
  - .4 Controller cabinets
  - .5 Vaults, valve boxes & lids
  - .6 Fittings
  - .7 Excavation, trenching, backfill, and restoration
  - .8 All incidentals necessary for the proper installation and operation of a complete irrigation control system

- .3 Supply and installation of pipes, valves, sprinklers and dripline will be measured as a lump sum. The work includes but is not limited to:
    - .1 Supply, installation, testing and adjustment of irrigation pipe
    - .2 Sleeves and conduit,
    - .3 Zone control valves
    - .4 Micro-irrigation control zone kits
    - .5 Electric control wire, common wire, flow sensor wire, and spare wires
    - .6 Drain valves
    - .7 Isolation valves
    - .8 Pressure regulators
    - .9 Swing joint assemblies
    - .10 Sprinklers
    - .11 Emitters, bubblers, dripline, and root watering systems
    - .12 Air / vacuum relief valves
    - .13 Fittings
    - .14 Vaults, valve boxes & lids
    - .15 Excavation, trenching, backfill and restoration
    - .16 All incidentals necessary for the proper installation and operation of a complete irrigation system
  - .4 Payment for Record Drawings and Operating Manual will be measured as a lump sum.
  - .5 Payment for irrigation system tests, inspections, maintenance, winterization and spring start-up during the warranty period will be incidental to the work under this section.
- 1.11 Tests and Inspections**
- .1 Refer to General Conditions, Clause 4.12, Tests and Inspections.
  - .2 At various milestones during construction inspection and testing of components will be required to ensure performance of irrigation system meets expected standards.
  - .3 Provide equipment and personnel necessary for performance of inspections and tests.

- .4 As a condition of issuance of Certificate of Substantial Performance confirm in writing to the City of Salmon Arm, at least one week prior to application for Substantial Performance, the following inspections and successful tests:
  - .1 Certified backflow prevention device test per BCWWA.
  - .2 Mainline pressure test
  - .3 System coverage and operation test
  - .4 Dripline/emitter inspection and test, if applicable
- .5 Conduct all inspections and tests in presence of Contract Administrator and request Contract Administrator issue signed report to Contractor within three days regarding each test result. Request attendance of Contract Administrator for proposed inspection or test at least 3 days prior to proposed inspection or test.
- .6 Keep work uncovered and accessible until successful completion of inspection or test.
- 1.12 Backflow Prevention Test**
  - .1 Conduct backflow prevention device test per American Water Works Association standard using qualified personnel.
- 1.13 Mainline Pressure Test**
  - .1 Perform mainline pressure test to identify potential leaks and ensure mainline is able to operate at design pressure and maintain system pressure. These tests to include longest run of pipe  $\frac{3}{4}$ " or larger within a distribution branch.
  - .2 Conduct mainline pressure test prior to backfilling of mainline.
  - .3 Fill mainline with water and expel all air from pipe. Maintain water in pipe as follows:
    - .1 24 hours for PVC mainline
    - .2 3 hours for HDPE mainline
  - .4 Subject mainline to hydrostatic pressure of 150psi or twice the optimum design operating pressure of the mainline and not to exceed 200psi.
  - .5 Stop supply of make-up water to mainline and record hydrostatic pressure in mainline.
  - .6 Visually inspect mainline and fittings for leaks.
  - .7 Record hydrostatic pressure in mainline 3 hours after supply of make-up water stopped.
  - .8 Determine test result based on difference in recorded pressures at beginning and end of test as follows:
    - .1 Passed test: Less than 5% difference
    - .2 Failed test: Difference of 5% or greater

- .9 Identify source of leak and replace any and all defective materials and workmanship as necessary to eliminate leak.
  - .10 Repeat mainline pressure test and make replacements as necessary until a passed result is achieved.
- 1.15 System Coverage and Operation Test**
- .1 Conduct system coverage and operation test after installation and operation of complete irrigation system and prior to issuance of Certificate of Substantial Performance.
  - .2 Conduct visual inspection to confirm that:
    - .1 Head spacing does not exceed that shown on Contract Drawings
    - .2 Where applicable, irrigation piping should be designed to follow the contours of the land in an effort to minimize low head drainage situations.
    - .3 Heads, boxes, vaults and trenches are at specified elevation relevant to finished grade and not subject to settlement or lifting
  - .3 Conduct operational tests to verify that:
    - .1 Controller can be programmed manually on site and remotely via Owner’s central irrigation control system
    - .2 Controller can send and receive communication with Owner’s central irrigation control system 10 consecutive times without a missed communication
    - .3 Controller responds to flow sensor
  - .4 Operating pressure is within design parameters
  - .5 Each zone can be operated automatically and in succession via programmed controller
  - .6 Performance provides head to head coverage
- 1.16 Dripline/Emitter Inspection**
- .1 Perform inspection and testing of dripline/emitter manifold and lines to identify potential leaks and confirm manifold, driplines and emitters are able to operate at design pressure. Conduct inspection and testing prior to backfilling of manifold, driplines or emitters.
  - .2 Fill manifold and lines with water at operating pressure and maintain pressure for 1 hour. Visually inspect manifold, driplines and fittings for leaks. Confirm that emitters are functioning correctly. Identify sources of leaks and replace any

and all defective materials and workmanship as necessary to eliminate leak.

- .3 Repeat inspection and testing and make replacements as necessary until no further leaks are identified.

**2.0 PRODUCTS**

**2.1 Water Service and Meter**

- .1 Unless already installed or otherwise required by the water utility having jurisdiction over the site provide a metered water service, including but not limited to:
  - .1 Plumbing permit
  - .2 Backflow prevention device; with permit as required
  - .3 Establishment and verification of water account with appropriate utility provider
- .2 Supply and install water meter in accordance with requirements of water utility.
- .3 Conform size of water meter to mainline diameter and allow for minimal pressure losses.

**2.2 Isolation Valve**

- .1 Acceptable isolation valves include the following:
  - .1 Up to 2” see Approved Products List
  - .2 Greater than 2” per Contract Drawings

**2.3 Flow Sensor**

- .1 Flow sensors impellers to be brass or stainless steel for up to 1” size, and glass filled nylon over 1” size, sized to match system low and high flows.
- .2 Acceptable wire for flow sensor to be shielded, direct burial instrument cable and includes the following:
  - .1 Beldan
  - .2 Approved Equal

**2.4 Master Valve**

- .1 Acceptable master valves are specified on the Approved Products List.
- .2 Ensure master valve is sized to maximum and minimum flow parameters shown on Contract Drawings.

**2.5 Pressure Reducing Valve**

- .1 Acceptable water pressure reducing valves are specified on the Approved Products List.

- |                                  |    |   |
|----------------------------------|----|---|
| <b>2.6 Backflow Prevention</b>   | .1 | Acceptable double check valve assemblies (DCVA) are specified on the Approved Products List.  |
|                                  | .2 | Acceptable Reduced Pressure Backflow Assemblies (RPBA) are specified on the Approved Products List.   |
|                                  | .3 | Refer to section 1.12.1 for backflow prevention test requirements.  |
| <b>2.7 Blowout Assembly</b>      | .1 | Blowout assembly to be 50mm brass gate valve with brass hydrant adapter and threaded cap on swing joint assembly.   |
| <b>2.8 Vault and Lid</b>         | .1 | Acceptable vaults and matching lids for point of connection equipment and components are dependent on service size, and are specified on the Approved Products List.  |
|                                  | .2 | Lids to have recessed hinges and locking hardware.  |
| <b>2.9 Irrigation Controller</b> | .1 | Irrigation controller and associated components per Drawings.   |
| <b>2.10 Controller Cabinet</b>   | .1 | Acceptable controller cabinets include the following:   |
|                                  | .1 | Double post # KSH-21  |
|                                  | .2 | Irrigation cabinet to be finished using:  |
|                                  | .1 | One coat of Zinc Chromate Primer (General Paint or Tremclad)  |
|                                  | .2 | Two coats of General Paint Exterior Alkyd #CW033W   |
|                                  | .3 | Cabinet hinges to allow for grease application.   |
| <b>2.11 Control Wire</b>         | .1 | Control wire from irrigation controller to electric control valve to be CSA approved, minimum #14 gauge, direct burial, type TWU-40 wire. Control wire to be any colour other than white, blue, purple, red or green. |
|                                  | .2 | Common wire from irrigation controller to electric control valve to be minimum #12 gauge direct burial, type TWU-40 wire. Common wire to be white in colour.  |
|                                  | .3 | Master valve wire from the controller to valve to be minimum #14 gauge direct burial, type TWU-40 wire. Wire to be red in colour.   |
|                                  | .4 | Spare control wire to be blue in colour.  |
|                                  | .5 | Spare common wire to be white in colour.  |
|                                  | .6 | All connectors to be new, two-step, CSA approved for water tight applications and assembled according to the manufacturer's recommendations.  |

- 2.12 Irrigation Sleeve**
- .1 Schedule 40 PVC for irrigation sleeve in bored hole or under hard surface.
  - .2 Irrigation sleeve diameter to be minimum 4" or twice the diameter of main or lateral line running through it, whichever is greater.
  - .3 Control wire conduit to be a minimum 2" diameter electrical conduit, per code.
- 2.13 Polyvinyl Chloride (PVC) Pipe**
- .1 Conform to CSA B137.3-93.
  - .2 New condition, extruded from virgin, high impact materials, solvent weldable with belled ends, continually and permanently marked showing manufacturer's name, material, size, pressure rating, and CSA approval.
  - .3 PVC pipe to be as follows:
    - .1 Class 200 PVC pipe for pipe sizes ¾" to 2¼" in diameter
    - .2 Bell & Spigot gasket joint pipe c/w concrete thrust blocking for pipe sizes 2½" in diameter and greater
- 2.14 Polyethylene (PE) Pipe**
- .1 New condition CSA Series 100, MDPE in new condition, extruded from virgin materials, continually and permanently marked showing manufacturers name, material, size, and pressure rating.
- 2.15 High Density Polyethylene (HDPE) Pipe**
- .1 New condition CSA Approved, extruded from virgin materials, continually and permanently marked showing manufacturers name, material, size, and pressure rating.
  - .2 Material to be listed by the Canadian Standards Association (CSA) and Plastic Pipe Institute (PPI) as a PE-3408 resin with a hydrostatic design basis (HDB) of 1600psi for water at 23°C. Material to comply with ASTM D-1248 as a Type III Class C, Category 5, Grade P34 material and with ASTM D-3350 as a 345434C cell material.
  - .3 Acceptable HDPE pipe is dependent on operating pressure and to have Standard Density Ratios (SDR) as follows:
    - .1 Max. pressure up to 100psi: SDR-17.0
    - .2 Max. pressure exceeding 100psi: SDR-11.0



- |                                  |    |   |
|----------------------------------|----|---|
| <b>2.16 Fittings</b>             | .1 | New condition Schedule 40 PVC conforming to ASTM D-2466-97 (and F438-97 for CPVC) standards and of the same material as pipe. Fittings to be designed for solvent welding to PVC pipe except where valves and risers require threaded joints. |
|                                  | .2 | Nipples to be threaded Schedule 80 PVC and manufactured from same material as the pipe.   |
|                                  | .3 | At the point where the supply source changes from metal to PVC pipe, the metal end of the pipe must be an FIPT (female) adapter and the PVC fitting a MIPT (male) adapter.  |
|                                  | .4 | Flange couplers may be used upon approval of Contract Administrator.  |
|                                  | .5 | Fittings for HDPE pipe to be Schedule 80 PVC insert fittings complete with stainless steel gear clamps.   |
|                                  | .6 | Fittings for HDPE pipe to be butt fusion type for end-to-end joints.  |
|                                  | .7 | SDR rating of HDPE fittings must match the SDR rating of the HDPE pipe specified.   |
|                                  | .8 | HDPE pipe fittings to be molded or fabricated by the pipe manufacturer. HDPE pipe fittings and flange adapters made by contractors or distributors are prohibited.  |
|                                  | .9 | Fittings for dripline and drip emitters to be compatible with specified dripline or emitter and as recommended by manufacturer.   |
| <b>2.17 Sprinklers - general</b> | .1 | Make, model, nozzle size, and features of sprinklers as specified on Contract Drawings.   |
|                                  | .2 | All sprinklers installed in sport field turf areas to be equipped with the manufacturer-supplied rubber covers.   |
| <b>2.18 Sprayhead Sprinkler</b>  | .1 | Acceptable sprayhead sprinklers are specified on the Approved Products List.  |
|                                  | .2 | Required pop-up height for sprayhead sprinklers to be as shown on Contract Drawings.  |
| <b>2.19 Rotor Sprinkler</b>      | .1 | Acceptable rotor sprinklers are specified on the Approved Products List.  |
| <b>2.20 Dripline</b>             | .1 | Dripline shall incorporate root intrusion technology and be as shown on Contract Drawings.  |
|                                  | .2 | Pressure compensating driplines are specified on the Approved Products List.  |

- |                                  |    |  |
|----------------------------------|----|--|
| <b>2.21 Drip Emitter/Bubbler</b> | .1 | Drip emitters/bubblers shall be as shown on Contract Drawings.   |
|                                  | .2 | Drip emitters/bubblers are specified on the Approved Products List.  |
| <b>2.22 Sand</b>                 | .1 | Sand to be pit run sand, per Section 31 05 17  |
| <b>2.23 Drain Rock</b>           | .1 | Drain rock to be drain rock, per Section 31 05 17.   |
| <b>3.0 EXECUTION</b>             |    |  |
| <b>3.1 Existing Conditions</b>   | .1 | Report existing conditions at variance with Contract Drawings to Contract Administrator.   |
|                                  | .2 | Verify locations of underground utilities prior to commencing excavation and conduct work so to prevent interruption and damage to services and utilities. Make good all damages to same at Contractor's cost.   |
|                                  | .3 | Verify location of all services in building walls before boring or drilling holes. Make good all damages to same at Contractor's cost.   |
|                                  | .4 | Protect existing conditions and completed work from disturbance during Work. Make good all damages to same at Contractor's cost.   |
|                                  | .5 | Adjustments to installation of irrigation system to avoid existing conditions, completed work and utilities will be permitted subject to prior approval by Contract Administrator.   |
| <b>3.2 Layout</b>                | .1 | Locations of irrigation components shown on plans is schematic in nature. Coordinate actual location of irrigation components with landscaping, building and physical features of site. Confirm proposed changes to location of irrigation components in writing with Contract Administrator prior to installation. Changes that markedly alter the irrigation design in the opinion of the City Engineers require submission of Shop Drawings and updated Irrigation Design Report to City of Salmon Arm for their permission to proceed. Record all approved revisions on a marked-up set of Contract Drawings |

- .2 Layout and stake irrigation system per Contract Drawings to confirm:
  - .1 Layout is within project boundary and property lines
  - .2 Site grades are consistent with Contract Drawings
  - .3 Damage to root system of existing trees is minimized
  - .4 Installation of irrigation components to be a minimum of 1 meter outside the dripline of existing trees
  - .5 Minimum horizontal and vertical clearances from electrical and other utilities are met
  - .6 Location of all sleeving, main lines, cabinets, vaults, valve boxes, splice boxes and ground grid assembly
- .3 Have layout inspected and approved by the Contract Administrator before commencement of work. Adjust layout as instructed by Contract Administrator.
- .4 During construction it may be necessary to adjust the layout of the irrigation system. Request layout changes to Contract Administrator prior to execution of work.
- .5 Do not modify irrigation layout without written approval of Contract Administrator.
- 3.3 Excavation**
  - .1 Excavate to ensure depth and bedding requirements are met.
  - .2 All excavation is unclassified. Report any material or site condition that cannot be excavated by normal mechanical or manual means or that may affect excavation to required depth to Contract Administrator prior to excavation.
  - .3 Identify and recycle all suitable materials recovered during construction.
  - .4 Remove and dispose of buried debris exposed during excavation, including decommissioned irrigation materials and underground utilities, which may impede the proper installation and operation of irrigation system.
- 3.4 Water Meter**
  - .1 Install water meter per Drawings and requirements of water utility.
- 3.5 Isolation Valve**
  - .1 Install isolation valve per Drawings.
- 3.6 Flow Sensor**
  - .1 Install flow sensor in location specified on Drawings.
  - .2 Flow sensor wire to run continuously, with no splices, between flow sensor and irrigation controller.
  - .3 Follow manufacturer’s recommendations for installation and wiring of flow sensor.
- 3.7 Master Valve**
  - .1 Install master valve per Drawings.

- |                                       |    |   |
|---------------------------------------|----|---|
| <b>3.8 Pressure Reducing Valve</b>    | .1 | Install pressure reducing valve (PRV) per manufacturer's recommendations in location shown on Contract Drawings and as required to maintain operating pressure within manufacturer's recommended range.   |
|                                       | .2 | Adjust PRV to provide water at design pressure for the sprinkler furthest from control valve.   |
| <b>3.9 Backflow Prevention Device</b> | .1 | Install Double Check Valve Assembly (DCVA) in lockable concrete vault or a locked mechanical room, per Drawings.  |
|                                       | .2 | Install Reduced Pressure Backflow Assembly (RPBA) a minimum of 300mm above finished grade per manufacturer's recommendations and Drawings. Install RPBA on reinforced concrete pad with pipe restraints bolted to floor to restrain and support assembly.   |
|                                       | .3 | Construct reinforced concrete pad for RPBA 150mm larger than the proposed enclosure in all directions. Construct reinforced concrete pad on a 150mm thickness of granular base compacted to 95% S.P.D. Provide vault drain directly below discharge valve and connect to drain pit, dry well, manhole or catch basin. |
|                                       | .4 | Install acceptable lockable enclosure over the RPBA large enough to secure the assembly and any associated components attached to this point.   |
|                                       | .5 | Install backflow prevention device in accordance with all applicable codes and bylaws and in accordance with the current Cross Connection Control Manual Accepted Procedure and Practice (American Water Works Association).  |
|                                       | .6 | Install backflow prevention devices with positive drainage and room for maintenance and servicing.  |
|                                       | .7 | Support backflow prevention device with specified supports per manufacturer's recommendations for locations of the support points.  |
| <b>3.10 Blowout Assembly</b>          | .1 | Install blowout assembly per Drawings.  |

**3.11 Vault and Lid**

- .1 Install vault in location shown on Contract Drawings or in alternate location approved or directed by Contract Administrator.
- .2 Support and brace point of connection components, piping and valves within vault using adjustable aluminum pipe stands complete with riser, pipe clamps, base plate and galvanized or stainless steel fittings in the quantity per service size indicated as follows:
  - .1 ¾" 2 supports
  - .2 1" to 2" 3 supports
  - .3 2 ½" to 3" 3 supports per vault
  - .4 Larger than 3" per Contract Drawings
- .3 Lids to have recessed hinges and locking hardware.
- .4 Use brass pipe for all piping inside vault and extend brass piping outside the vault a minimum of 300mm beyond vault. Make union of brass pipe with other pipe in valve box or vault using specified fitting.
- .5 Make connections of PVC pipe and metal pipe using male threads on PVC pipe and female threads on metal pipe.
- .6 Install vault drain and connect to drain pit, dry well, manhole or catch basin.

**3.12 Irrigation Controller**

- .1 Install irrigation controller in controller cabinet.
- .2 Coordinate controller installation with that of other electrical components.
- .3 Install controller and wiring in accordance with local, provincial and national electrical codes.
- .4 Install and test the ground assembly using a "Megger" to ensure earth resistance to ground does not exceed controller manufacturer's recommendations.
- .5 Install communication components per manufacturer's recommendations and establish communication between controller and Owner's central irrigation control system, including relays or boosters as necessary.
- .6 Prior to issuance of Certificate of Substantial Performance request irrigation program from Contract Administrator and set controller program accordingly.

- |                                    |    |   |
|------------------------------------|----|---|
| <b>3.13 Controller Cabinet</b>     | .1 | Install controller cabinet in location shown on Contract Drawings or in alternate location approved or directed by Contract Administrator.  |
|                                    | .2 | Orient alignment of controller cabinet as approved by Contract Administrator to provide optimal observation of irrigation system in operation.  |
|                                    | .3 | Install controller cabinet using a poured in place concrete pad mount.  |
|                                    | .4 | Provide electrical service to controller cabinet as shown on Contract Drawings.   |
|                                    | .5 | Install electric meter in the irrigation cabinet per electrical utility's requirement.  |
|                                    | .6 | Install only GFI breakers in controller cabinet electrical panel.   |
|                                    | .7 | Install 1 duplex 120v AC GFI receptacle, on dedicated breaker, in controller cabinet.   |
| <b>3.14 Electric Control Valve</b> | .1 | Install in valve box per manufacturer's recommendations and Drawings.   |
|                                    | .2 | Identify electric control valve with permanent label or tag indicating zone number of valve.  |
| <b>3.15 Manual Control Valve</b>   | .1 | Install in valve box per manufacturer's recommendations and Drawings.   |
|                                    | .2 | Identify manual control valve with permanent label or tag indicating zone number of valve   |
| <b>3.16 Valve Box</b>              | .1 | Install all manual and electric control valves, control zone kits and quick coupler valves in valve boxes or concrete vault as shown on Drawings.   |
|                                    | .2 | Except as shown otherwise on Contract Drawings or approved otherwise by Contract Administrator, locate valve boxes in planting beds and locate for ease of access, maintenance, and testing.                |
|                                    | .3 | Install valve box flush with finish grade and arrange in a neat and orderly manner.   |
|                                    | .4 | Provide minimum 150mm clearance between valve box and all components within.  |
|                                    | .5 | Valve box must not contact irrigation pipe. Use 150mm height matching valve box extensions as required.   |
|                                    | .6 | Up to three 1" control valves or two 1½" control valves may be contained within a single valve box provided there is 100mm of clearance between valves. Install valve 2" and larger in their own valve box. |

**3.17 Control Wire**

- .1 Install control wire per code and by qualified personnel employed by the company holding the electrical permit.
- .2 Bury control wire per applicable code and in no case above the bottom side of parallel pipe.
- .3 Bed control wire in sand with minimum 50mm sand around control wire. Where control wire is in same trench as pipe, place wire beside pipe with horizontal clearance of a minimum of 50mm and in accordance with BC Electrical Code depth.
- .4 Bundle multiple lengths of wire in same trench or conduit with ties at maximum 3.0m intervals.
- .5 Install wire with minimum 600mm length of coiled slack at all changes of direction, in wire splice boxes and at connections to controlled components.
- .6 Identify all control wires entering controller cabinet with permanent label or tag indicating zone number of valve operated by each control wire.
- .7 Maintain consistent wire colour through wire splice box.
- .8 Minimize wire splices. Where wire splices are unavoidable make splice only in wire splice box using specified connector.
- .9 Identify spliced wire with permanent label or tag indicating zone number of spliced control wire.
- .10 Where specified on Contract Drawings, install extra control wire to wire splice box. Provide 600mm length of coiled slack of each wire end in wire splice box. Identify extra control wire as 'extra' wire with permanent label or tag.

**3.18 Wire Splice Box**

- .1 Locate wire splice box in planting bed where possible and locate for ease of access, maintenance, and testing.
- .2 Install wire splice box per Drawings and arrange in a neat and orderly manner.
- .3 Do not install valves in wire splice box.

- 3.19 Irrigation Sleeve**
- .1 Install irrigation sleeves in locations shown on Contract Drawings.
  - .2 Install irrigation sleeve to depth as follows:
    - .1 Mainline Piping
      - .1 600mm below walkways
      - .2 750mm below driveways, roads and plazas
    - .2 Lateral Piping
      - .1 300mm below walkways
      - .2 600mm below driveways, roads and plazas
  - .3 Install sleeve to extend 1.0m past edge of hard surface into soft landscape surface.
  - .4 Cap sleeve with removable plug or cover. Maintain plug in sleeve until such time as pipe or wire is ready to be installed.
  - .5 Bed sleeve as follows:
    - .1 Under walkways, 100mm of sand placed all around
    - .2 Under driveways, roads and plazas, compacted base aggregate all around per materials shown on Drawings.
  - .6 Bury a piece of detectable metal on top of each end of sleeve to enable location of sleeve end by metal detector after burial.
  - .7 Stake location of each end of sleeve prior to backfilling such that top of stake is 300mm above finished grade and maintain. Label exposed end of stake with the word "sleeve".
  - .8 Record location of sleeve ends and label size of sleeve on Record Drawings.
  - .9 Remove sleeve stake after submission of Record Drawings.
- 3.20 Pipe and Fittings**
- .1 Verify that all pipe, fittings, primer and cements are compatible for proper installation.
  - .2 Minimum burial depth and clearances for pipe and wire to be per Drawings.
  - .3 Do not locate open side of trench any closer than 300mm from hard surface or feature.
  - .4 Keep inside of pipe and outside of pipe ends clean at all times. Cap or plug open pipe ends to keep out dirt and debris.
  - .5 Cut PVC pipe ends at right angle to pipe length. Clean burrs prior to joining pipe and fittings.
  - .6 Do not apply cement or solvent weld pipe or fittings under wet or muddy conditions.
  - .7 Follow manufacturer's recommendations for use of pipe primer and cement.



- .8 Immediately prior to joining pipe and fittings wipe contact surfaces clean with primer on clean rag.
- .9 Apply light coat pipe of cement on inside of fitting and heavier coat on outside of pipe. Insert pipe into fitting and give a quarter turn to seat cement. Wipe excess cement from outside of pipe.
- .10 Make plastic to metal joints with plastic male adapters.
- .11 Wrap male threads of threaded fittings with minimum 3 wraps of Teflon tape immediately prior to making connection.
- .12 Flush all irrigation pipe fully to remove accumulation of dirt and debris prior to installation of heads, dripline, emitters and filters. Flush all laterals in a manner approved by the manufacturer to prevent clogging of screens, nozzles and emitters.
- .13 Follow manufacturer's recommendations to install pipe in a manner that provides for expansion and contraction of pipe in trench.
- .14 Conduct water service flow test and obtain approval of Contract Administrator prior to backfilling main line.
- .15 Conduct mainline pressure test and HDPE pipe strap test and obtain approval of Contract Administrator prior to backfilling lines.
- .16 For HDPE pipe conduct HDPE pipe strap test and obtain approval of Contract Administrator prior to backfilling HDPE pipe.
- .17 Set mainlines and laterals on sand and backfill with sand to clearance limit shown on Drawings.
- .18 For pipe in growing medium of landscaped areas backfill trench with growing medium and tamp in lifts to achieve compaction equal to the adjacent growing medium.
- .19 For pipe in native soil, sub-surface fill, rocky soils and aggregate base or subbase material backfill remainder of trench with suitable non-sand material under 25mm in diameter and free of materials that could result in settling or damage to pipe or surface improvements.
- .20 Install 14 gauge insulated trace wire (purple) on top of all mainline and lateral piping. Extend and fasten tracer wire into valve boxes, vaults and sleeves.
- .21 Install thrust blocks where required in Contract Drawings.

Irrigation System

- |                                      |    |  |
|--------------------------------------|----|--|
| <b>3.21 Sprinkler</b>                | .1 | Install per manufacturer’s recommendations and in location shown on Contract Drawings.   |
| <b>3.22 Dripline</b>                 | .1 | Install per manufacturer’s recommendations in location shown on Contract Drawings.   |
| <b>3.23 Emitter/Bubbler</b>          | .1 | Install per manufacturer’s recommendations and as shown on Drawings.   |
| <b>3.24 Hose Bib</b>                 | .1 | Install as shown on Drawings   |
| <b>3.25 Clean-up and Restoration</b> | .1 | Remove all waste and debris resulting from irrigation installation from site.  |
|                                      | .2 | Restore all disturbed surfaces to original condition and repair all trench settlement.   |
| <b>3.26 Instructions to Owner</b>    | .1 | Instruct Owner in complete operating and maintenance procedures for irrigation system, including start-up, winterization, and programming.   |
|                                      | .2 | Review Record Drawings and Operating Manual with Owner on site.  |
| <b>3.27 Maintenance General</b>      |    | Inspect, operate, maintain and adjust irrigation system through the Landscape Maintenance Period until issuance of Certificate of Acceptance to ensure it operates as intended, including but limited to: <ul style="list-style-type: none"> <li>.1 Adjust irrigation program to ensure survival, health and growth of the plant material and respond to soil conditions, climate and seasons of site</li> <li>.2 Clean sprinkler heads and adjust coverage to eliminate over watering, under watering and overspray onto adjacent surfaces</li> <li>.3 Monitor and clean filtration equipment</li> <li>.4 Restore grass areas, planting beds, hard surfaces and improvements affected by trench settlement and erosion</li> <li>.5 Respond to requests from Contract Administrator for program adjustments, servicing, adjustments and repairs</li> </ul> |

**3.28 Maintenance  
Winterization**

- .1 During Landscape Maintenance Period be responsible for winterization of irrigation system at end of growing season and prior to onset of air temperatures below 0° Celsius. Be liable for any damage resulting from late or improper winterization.
- .2 Request presence of Owner at winterization at least 5 days prior to proposed winterization.
- .3 Winterization includes but is not limited to:
  - .1 Saturation of soil with water to a depth of 300mm to provide deep watering of all lawn areas, planting beds and tree pits
  - .2 Deactivation of controller
  - .3 Drainage and blow-out of entire irrigation system
- .4 Contact water utility provider to determine if water meter is to be removed for winter. Remove and store water meter, or assist the water utility with removal of water meter, as directed by water utility.

## 1.7 Scheduling of Work

Replace: .2 Submit schedule of interruptions to Contract Administrator for approval at least 48 hours prior to any planned interruption and adhere to approved schedule.

Add: .6 In the event water service has not been returned within one hour of the anticipated time, the contractor shall re-notify all customers of the unscheduled delay in resumption of water service.

## 2.2 Mainline Pipe, Joints and Fittings

Add: .1.3 Minimum pressure class for ductile iron pipe shall be 350 for 100 mm to 300 mm, 250 for 350 mm to 500 mm, 200 for 600 mm and 150 for 900 mm.

Add: .2.1.5 Colour: Blue

## 2.3 Valves and Valve Boxes

Add: .2.8 Gate Valves shall be epoxy coated.

Remove: .6.1.1 (Rectangular not permitted)

Add: 7.6. Colour: Curb stop valve boxes to be painted blue.

Add: 7.7. Protective pre-cast concrete valve boxes with cast iron lids as specified on contract drawings.

## 2.4 Valves and Large Meter Chambers

Replace: .8 Refer to Section 33 44 01, 2.1.8 for Ladder Rung Specifications.

Add: .11 Refer to Section 33 44 01, 2.1.24 for Manhole Liner Specifications.

Add: .12 Refer to Section 33 44 01, 2.1.16 for Adjustment Ring Specifications.

## 2.5 Service Connections

Add: .1.2 Service pipe shall be manufactured with a co-extruded UV shield made from UV resistance high-density polyethylene, color Sky Blue (International Thermoplastic Color Code, RAL 1501).

Add: .6 14 Gauge Solid White Tracer wire required on all services.

## 2.6 Hydrants

Add: .1.12 Hydrants to be flow tested by the City or an approved consultant. A completed form F-11 shall be submitted to the City.

Replace: .2 Colour: All hydrants are to be painted in accordance with the City Supplement Standard Drawing W-3.

### 2.10 Water Meters

Add: .1 Water Meters: Water meters shall be supplied by the City of Salmon Arm at the expense of the contractor to the specifications shown on the contract drawings.

Add: .2 Meter Vaults: As shown on the contract drawings.

### 3.3 Trenching

Replace: .3 Trench depth to provide cover over pipe of not less than 1.8 m from finished grade unless shown otherwise on Contract drawings.

### 3.6 Pipe Installation

Replace: .6 Pipe to be laid on a horizontal curve shall not be permitted unless otherwise specified by the Contract Drawings. If specified in the Contract Drawings, horizontal deflections shall not exceed one half the maximum deflection recommended by the manufacturer. For PVC pipe deflections exceeding those stated above, use:

.1 PVC High Deflection coupling rated at 1380kPa (100mm – 300mm)

.2 PVC long radius 5 degree bend rated at 1620kPa (100mm – 750mm)

### 3.10 Service Connection Installation

Add: .13 Where services are located in driveways, inspection chambers and curb stops shall be located within protective concrete vaults.

Add: .14 Install tracer wire from mainline corporation stop along service to finished grade on curb stop.

### 3.12 Hydrants

Replace: .6 Hydrants shall be covered with a black plastic bag and secured at the bottom until such time as they have been accepted by the Contract Administrator and City Engineer and the Salmon Arm Fire Department has been notified that they are fully operational.

### 3.24 Bacteriological Tests

Add: .1 Bacteriological tests shall be as per the current ANSI/AWWA C651 Standard for Disinfecting Water Mains.

Add: .2 Bacteriological water samples shall be collected from new watermain installations following the satisfactory completion of main chlorination and flushing. The owners' consulting engineer shall collect water samples. Such bacteriological testing shall be done using full aseptic precautions. The sample shall be taken from a copper gooseneck assembly provided by the contractor. The contractor shall be responsible to ensure the gooseneck assembly is contaminant free. Water shall be run from the sample tap for a minimum of 2 minutes prior to sampling. The water shall run at a constant rate prior to and during the sampling procedure. A sterile water sampling bottle must be obtained from the local Health Unit, and shall be used to collect the water sample. The cap of the bottle shall be removed after the water has run for 2 minutes, taking special precautions to not touch or contaminate the underside of the lid or the bottle rim. The bottle shall be filled to the fill line and then recapped immediately. Hose pipe shall never be used as a sample source. The sample shall be labelled completely indicating time, location, project, contract number and sampler. Sample bottles shall then be immediately placed in a cooler with an ice pack. Samples shall be transported to a testing facility acceptable to the City within 8 hours of sampling. The owners' consulting engineer is responsible for delivery and obtaining and reporting the test results. In no case shall samples take more than 24 hours to reach the testing facility approved by City Engineer. At least one sample shall be collected from each new main. In the case of long mains a sample shall be collected at 250 meter intervals as well as at its ends. At least one sample shall be taken from the source of water supply to determine the status of the distribution system at the time of sampling. If, in the opinion of the City Engineer, the pipeline has been contaminated with trench water, excessive quantities of dirt or debris, bacteriological water samples shall be collected at 60 meters intervals after water has stood in the main for at least sixteen (16) hours after final flushing or recommended by the City Engineer. Re-disinfection and re-sampling shall be required for all watermains that do not satisfactorily meet Interior Health Authority bacteriological requirements as amended from time to time.

**PART 1 GENERAL****1.1 General**

- .1 The work specified in this section consists of furnishing and installing underground utilities using the horizontal directional drilling (HDD) method of installation, also commonly referred to as directional boring or guided horizontal boring. This work shall include all services, equipment, materials, and labor for the complete and utilities and environmental protection and restoration.
- .2 This section must be referenced to and interpreted simultaneously with all other sections pertinent to the works described herein.

**1.2 Related work**

- |    |  |                  |
|----|--|------------------|
| .1 | Excavating, Trenching, and Backfilling       | Section 31 23 01 |
| .2 | Traffic Control, Vehicle Access, and Parking | Section 01 55 00 |
| .3 | Manholes & Catchbasins                       | Section 33 44 01 |
| .4 | Water Works                                  | Section 33 11 01 |

**1.3 Definitions**

- .1 **Annular Space**—The void created between the outside diameter of pipe being installed and extreme outer limits created by HDD bore process.
- .2 **Lubricant**—A substance applied between the pipe and soil to minimize friction and to fill the annular space.
- .3 **Horizontal Directional Drilling (HDD)**

Directional drilling is a means of installing or replacing underground utilities. Directional boring is a two-stage process. In stage one; a steerable drill head bores a pilot hole to a pre-designated point. In Stage two, the drill head is removed and, depending on the size of the product being installed, is replaced with a reamer to help open the path. A swivel is inserted between the reamer and the product to be installed to allow the reamer to rotate without twisting the product. At this point the entire assembly is pulled back through the pilot hole to the entry pit.

- 1.4 Quality Assurance** .1 The requirements set forth in this document specify a wide range of procedural precautions necessary to insure that the very basic, essential aspects of a proper directional bore installation are adequately controlled. Strict adherence shall be required under specifically covered conditions outlined in this specification. Adherence to the specifications contained herein, or the Engineer's approval of any aspect of any directional bore operation covered by this specification, shall in no way relieve the Contractor of their ultimate responsibility for the satisfactory completion of the work authorized under the Contract.
- 1.5 Environmental Protection** .2 All horizontal directional drilling works crossing a watercourse to be done in accordance with Fisheries and Oceans Canada Pacific Region Operational Statement Directional Drilling Notification Package (Version 3 document DFO /2007 – 1283)
- 1.6 Codes and Standards** .1 In addition to all codes and standards referenced elsewhere in the Contract Documents, all materials and equipment supplied, and work performed herein shall conform to the latest edition of the applicable industry codes, standards, references and recommended practices.
- 1.7 HDD Process** .1 The Contractor shall furnish all material, supervision and labour, including consumables and materials of a temporary nature, which are not specifically provided by the owner as per Contract Documents. The Contractor shall also furnish all other services and work documents as required for the Work and in accordance with the requirements set forth in the Contract Documents.
- .2 The Contractor shall supply Horizontal Directional Drilling equipment, tools, supplies and components in first class working order sufficient and all-encompassing to enable the project to be carried out in a continuous and uninterrupted manner. The directional drilling equipment shall consist of a directional drilling rig of sufficient capacity to perform the bore and pullback of the pipe; a drilling fluid mixing, delivery and recovery system of sufficient capacity to successfully complete the borehole; a drilling fluid recycling system to remove solids from the drilling fluid so that the fluid can be re-used; a guidance system to accurately guide boring operations; a vacuum truck of sufficient capacity to handle the drilling fluid volume; and trained and competent personnel to operate the system.
- .3 All equipment shall be in good, safe operating condition with sufficient supplies, materials and spare parts on hand to maintain the system in good working order for the duration of the project.



- .4 The Contractor shall furnish all material, supervision and labour, including readout instrumentation, steering tools, etc. The instruments should provide data on pilot hole location at all times.
- .5 The Contractor shall also provide a capable and experienced mud engineer to monitor and maintain mud properties as necessary for this procedure, sufficient drilling crews experienced and competent in the operation of the above rigs, and surveyors experienced and capable of operating the above equipment.

### 1.8 Incidental items

The Contractor shall supply and maintain:

- .1 Temporary fences, fence repair materials, temporary gates, permanent gates, if required.
- .2 Sand bags (sack breakers) including bags, sand, earth and cement, as required.
- .3 All fusion bond, joint, patch and repair materials, and a data logger to permit continuous recording during pipe jointing, McElroy DL2001, or approved equivalent for PVS pipe fusion
- .4 All welding supplies and materials, and a data logger to permit continuous recording during pipe jointing for steel pipe welding.
- .5 All pigs, launchers, receivers, test heads and compressors necessary for cleaning, gauging, hydrostatic testing of the pipe.
- .6 All dead weight testers, hoses, fittings, pressure and temperature recorders and chart paper required for hydrostatic testing as outlined in the specifications.
- .7 All materials and equipment for hydrostatic testing.
- .8 All materials and equipment to heat, hoard and cover work area, as required, during inclement weather conditions.
- .9 All dunnage, straps, chains, padding, spreader bars etc., required for loading, hauling, stockpiling and stringing of pipe.
- .10 All welding, pipe jointing consumables.
- .11 Pipe pulling swivel and pipe pulling heads complete with connections with a design rated strength equal to that of the rig capacity plus 25%
- .12 All fuels, Oils, and greases.

- 
- .13 All culverts, as required.
  - .14 All cement, cement additives, mixing water, cement mixing and pumping equipment and grouting tools required to complete the Works. The Contractor shall provide, if required by conditions of lost circulation, suitable cement and grouting tools such as lightweight slurry, open hole packers, and stage tools. All above tools shall be drillable to full open inside diameter after serving their intended function.
  - .15 All necessary mud pits and slurry mixing and cuttings separation equipment. The Contractor Shall immediately clean up any drilling mud, which spills or overflows from these pits or equipment. Disposal of spilt or excess drilling fluid shall be the responsibility of the Contractor.
  - .16 Sufficient spares or replacement items of above equipment to maintain directional drilling capacity at all times.

**1.9 Materials  
Supplied by the  
Owner**

- .1 The Owner will provide the Right of Way for the work and the Work and Storage Areas.
- .2 The Owner will provide water at a source near the site. The Contractor shall provide an approved valve through which they can draw water. The hydrant valve and/or hydrant shall not be used to control water. The hydrant shall be securely closed when no work is actively being carried out. Water shall not be wasted; if it is, the Engineer may terminate the supply and Contractor shall then be responsible for obtaining water elsewhere.

**1.10 Mobilization**

- .1 Mobilization for the works covered by this Specification shall include the assembly and transportation to the works Site of all equipment, materials and personnel necessary to perform the Work. This shall include, but not be limited to the following items:
  - Initial site survey (several survey reference points will be provided by the Owner);
  - Drilling and downhole survey equipment;
  - Drilling materials;
  - Grouting equipment;
  - Grouting materials;
  - Procurement of all permits and licenses for the execution of the

Works, except for those obtained by the Owner; and Approval by the Engineer of all preconstruction submittals required by this Specification;

- .2 Mobilization and site preparation shall not be considered complete until the above equipment has been completely rigged up and in position at the site and ready to commence work.

### **1.11 Right of Way and Work and Storage Area**

- .1 The right-of-way configuration is shown on the Drawings forming part of the Contract Documents. The Contractor is advised that all operations must be strictly confined to the areas identified unless they obtain specific permission.
- .2 The Contractor shall familiarize themselves with the layout areas and make such allowances as may be necessary for any stops and intermediate welds. Any additional working space required by the Contractor for such uses as pipe(s) layout, Storage of spoil material, equipment turnarounds, vehicle servicing and fueling yards, access to the right-of-way and other requirements shall be obtained by the Contractor at the Contractor's expense and such agreements shall meet the Owner's requirements. The Contractor shall provide a copy of all such agreements made with the occupants to the Owner prior to the use of the additional work areas covered by those agreements.
- .3 The pipe shall be installed to the alignment and elevation shown on the drawings unless approved otherwise. The Owner shall have the right to make any changes necessary in the location of the proposed sanitary sewer or appurtenances, and if the change results in increasing or decreasing the cost of the Contractor in comparison with what its cost would have been had no change been made, the Contract Price will be equitably adjusted.

### **1.12 Access**

- .1 Access to the site shall be through the existing Municipal Roadways and Right of ways in accordance with the Contract Documents. The Contractor shall provide cleared work areas at the entry and exit sites and shall ensure suitably dry working conditions.
- .2 Except as specifically noted herein, uninterrupted vehicle traffic movement shall be maintained at all times on all public roads and private access points. The Contractor shall identify within their work plan the proposed site preparation work, equipment, and procedures to satisfy this requirement. The Contractor shall be responsible for all

traffic control, and obtaining traffic control permits and carrying out their requirements if necessary.

- .3 When its operations are conflicting with normal traffic, the Contractor shall provide suitable detours, at the discretion of the Owner. All detours shall be clearly marked to the satisfaction of the Engineer. The Contractor shall furnish and maintain all necessary day and night warning signs, flares lanterns, barricades and flagmen when working on near roads, highways, or traffic ways, to protect all persons from injury and property from damage, and to warn the drivers of vehicles of the obstruction.

### 1.13 Fences

- .1 Temporary fences shall be erected, and maintained, where necessary, for the protection of public safety.

### 1.14 Demobilization and Restoration

- .1 Demobilization shall include the following:
  - Dismantling and removal of all equipment and material mobilized by the Contractor.
  - Disbanding of the Contractor's personnel.
  - All site restoration and clean up.
  - Submission of all drilling, inspection, and test records and as-built drawings to the Engineer.
- .2 Restoration shall include cleaning, backfilling, paving and landscaping with compatible turf (where appropriate) of the entry and exit pits, mud and cutting separation pits with compacted general fill to pre-construction conditions, in a manner acceptable to the Engineer.
- .3 It is the Contractor's responsibility to remove all construction materials from work site after completion, and to ensure that the clean-up and site restoration are in accordance with the environmental requirements defined herein, and to the satisfaction of the Owner, landowner and/or occupant and the authority having jurisdiction.
- .4 Upon completion of the remaining work, the Contractor shall be responsible for removal from the site, and satisfactory disposal off site, of all deleterious materials, including materials from sediment ponds, excess excavation spoil., organic material, excess construction materials, brush, broken or cast off machinery, and any other construction debris. The Contractor shall remove from the work site all equipment, tools unused materials and accessories used in the construction.

- 
- .5 No rubbish or garbage may be buried or burnt on any construction site. It is the responsibility of the Contractor to make their own arrangements for the disposal of all garbage.
  - .6 The Contractor shall pump and totally remove all drilling fluids and cuttings and shall transport and dispose such material at an approved disposal site in accordance with the environmental requirements defined herein.
  - .7 The Contractor shall be responsible for the protection of existing road pavements during construction and shall be responsible for any damage to these pavements caused by their operations. The contractor shall repair and make good the damage at their own expense to the satisfaction of the Owner, landowner and/or occupant, or other authorities having jurisdiction over said roads or properties.
  - .8 In the event that the Contractor is either unwilling or unable to obtain damage releases for damages incurred by the Contractor off the right-of-way and working space, the Owner shall have the right to settle such damages on behalf of the Contractor. The costs of such settlements shall be subtracted from monies owing to the Contractor.
  - .9 The Contractor shall be responsible for the supply, placement and compaction of all materials required to carry out the site restoration activities described in the Project Documents. Subject to approval by the Engineer, it may be possible to re-use the existing site fills for the site restoration activities, providing that they have been suitably separated and stored.
  - .10 Upon completion of the Work, the Contractor is responsible for providing an as-built survey of all the installations for the permanent records of the Owner.
- 
- 1.15 Directional Drilling Supervision and Personnel**
    - .1 The Contractor shall ensure that all directional drilling and pull-back operations are performed with the operation of the equipment and drilling in subsurface materials similar to those expected to be encountered within the proposed installation.
- 
- 1.16 Directional Drilling Surveying**
    - .1 The Contractor shall survey the site to accurately establish the entry points, exit points and azimuths of the pilot hole. The Contractor shall place and maintain their own benchmarks, survey monuments and

other positioning aids as required for the duration of the Works. The Contractor shall be responsible for providing the necessary construction surveys required for the entire construction work shown on the drawings.

- .2 The Contractor shall be responsible for survey monitoring of the existing facilities, buried services, and lands as identified in the Contract Documents.
- .3 Upon completion of the Work, the Contractor is responsible for providing an as-built survey of all the installations for the permanent records of the Owner.

**1.17 Drilling System**

- .1 DRILLING RIG: The directional drilling machine shall consist of a hydraulically powered system to rotate push and pull hollow drill pipe into the ground at a variable angle while delivering a pressurized fluid mixture to a guidable drill (bore) head. The machine shall be anchored to the ground to withstand the pulling, pushing and rotating pressure required to complete the crossing. The hydraulic power system shall be self-contained with sufficient pressure and volume to power drilling operations. Hydraulic system shall be free of leaks. Rig shall have a system to monitor and record maximum pullback pressure during pullback operations.

The rig shall be grounded during drilling and pullback operations. There shall be a system to detect electrical current from the drill string and an audible alarm, which automatically sounds when an electrical current is detected.

- .2 DRILL HEAD: The drill head shall be steerable by changing its rotation and shall provide the necessary cutting surfaces and drilling fluid jets.
- .3 MUD MOTORS (if required): Mud motors shall be of adequate power to turn the required drilling tools.
- .4 DRILL PIPE: Shall be as specified on Contact Drawings

**1.18 Drilling Fluid  
(Mud) System**

- .1 MIXING SYSTEM: A self-contained, closed, drilling fluid mixing system shall be of sufficient size to mix and deliver drilling fluid. The drilling fluid reservoir tank shall have sufficient capacity to supply volume of

drilling fluid. Mixing system shall continually agitate the drilling fluid during drilling operations.

- .2 DRILLING FLUIDS: Drilling fluid shall be composed of clean water and appropriate additives and clay. Water shall be from an authorized source with a pH of 8.5-10. Water of a lower pH or with excessive calcium shall be treated with the appropriate amount of sodium carbonate or equal. The water and additives shall be mixed thoroughly and be absent of any clumps or clods. No potentially hazardous material may be used in drilling fluid.
- .3 The use of drilling muds or drilling mud additives that contain toxic constituents is prohibited. Upon award of the Contract, the Contractor shall supply copies of Material Safety Data Sheets (MSDS) for the drilling muds and drilling mud additives, which are proposed to be used during the project for review by the Engineer. By reviewing the MSDS information to be supplied and submitted by the Contractor, the Owner and Engineer shall in no way assume responsibility or liability for the constituents of the drilling mud or drilling mud additives.
- .4 Construction and excavation wastes, overburden, soil, drill cuttings or fluid, or other substances deleterious to aquatic life must be disposed of or placed in such a manner by the Contractor to prevent their entry into watercourses.
- .5 The Contractor shall recycle and reuse, as much as practically possible, all drilling muds used in the HDD operations including, but not limited to, drilling of the pilot hole, reaming of a larger size diameter hole to facilitate pipeline placement and pulling of the pipeline through
- .6 Drilling muds shall be directed or pumped into tank(s) and/or pond(s), which must be adequately sized to prevent spillage or release of spent drilling muds from entering watercourses. Upon completion of the directional drilling activities, the spent drilling muds from entering watercourses. Upon completion of the directional drilling activities, the spent drilling mud must be removed from the site and disposed of offsite to an approved landfill, or other approved facility.
- .7 During the drilling of the pilot hole and reaming for the hole opening operations, the Contractor shall continuously monitor for the potential loss of drilling fluid by detaining the amount of fluid returned to the drill pit in front of the drill rig and the quantity of make-up drilling fluid required in the mixing tanks.

- .8 Line inspection personnel shall be onsite at all times during drilling, reaming and pipe installation procedures to ensure all preventative and, if necessary, emergency response measures will be implemented effectively in the event of a mud release.
- .9 The Contractor shall immediately inform the Engineer of any losses in drilling fluid or losses in drilling fluid pressures and shall immediately implement emergency response actions as required.
- .10 Emergency response equipment necessary to contain drilling fluid losses shall be onsite and available for immediate use at all times to contain the movement of the drilling mud.
- .11 Once a drill fluid loss is detected, the Contractor shall immediately halt drilling operations and conduct a detailed examination of the drill path. If no fluid migration to the ground surface is identified, drilling operations may resume paying particular attention to drilling fluid consumption and pressures.
- .12 In the event of fluid migration to the surface occurring on land away from the wetted perimeter of watercourses, the Contractor shall halt drilling operations immediately, isolate the affected area using sandbags or other suitable materials, and recover the drilling fluids using vacuum trucks or mud/trash pumps. The drilling operations can proceed only after these remedial measures have been taken to the satisfaction of the Engineer.
- .13 In the event of drilling fluid release into watercourses and/or into the ditch or storm sewer which discharges into the Municipal storm sewer system, the Contractor shall halt drilling operations immediately and undertake the following remedial actions:
  - Contain the drilling muds to prevent further discharge into watercourses and/or into the ditch. In the case of an instream mud release, all reasonable efforts shall be made to prevent the downstream movement of the drilling mud. This may involve the installation of an instream containment structure.
  - Notify the Engineer of an inadvertent mud release and advise of the efforts being undertaken to seal the leaking area and of any mitigative measures implemented to address environmental concerns.
  - Obtain representative water quality samples and photographs of stations located upstream (control site), immediately downstream of the drilling mud release location and approximately 500 meters downstream (depending on creek conditions).
  - Evaluate the source of the drilling mud release and the location of



the fracture points(s), and develop a plan for preventing further release of drilling mud into watercourses and/or the ditch or storm sewer which discharges into the Municipal storm sewer system.

- Develop and implement a cleanup and remedial plan in consultation with the Ministry of Environment and the Department of Fisheries and Oceans (DFO).
- Water for Hydrostatic Testing and Buoyancy Control: Water to be used for the hydrostatic pressure testing and to control buoyancy during pull-through of the pipeline shall be withdrawn from a municipal fresh water source. The Owner will arrange for a source of water in the vicinity of the work site.
- The Contractor shall dispose of test water from the hydrostatic pressure testing in a manner satisfactory to the Engineer.

.14 DELIVERY SYSTEM: The mud pumping system shall have a sufficient capacity and be capable of delivering the drilling fluid at a constant minimum pressure. The delivery system shall have filters in-line to prevent solids from being pumped into the drill pipe. Connections between the pump and drill pipe shall be relatively leak-free. Used drilling fluid and drilling fluid spilled during drilling operations shall be contained and conveyed to the drilling fluid recycling system. A berm, minimum of 300 MM high, shall be maintained around drill rigs, drilling fluid mixing system, entry and exit pits and drilling fluid recycling system to prevent spills into the surrounding environment. Pumps and or vacuum truck(s) of sufficient size shall be in place to convey excess drilling fluid from containment areas to storage and recycling facilities.

.15 DRILLING FLUID RECYCLING SYSTEM: The drilling fluid recycling system shall separate sand, dirt and other solids from the drilling fluid to render the drilling fluid re-usable. Spoils separated from the drilling fluid be stockpiled for later use or disposal.

**1.20 Other  
Equipment:**

.1 PIPE ROLLERS: Pipe rollers shall be of sufficient size to fully support the wight of the pipe while being hydro-tested and during pullback operations. Sufficient number of rollers shall used to prevent excess sagging of pipe.

.2 PIPE RAMMERS: Hydraulic or pneumatic pipe rammers may only be used if necessary and with the authorization of Engineer.

.3 RESTRICTIONS: Other devices or utility placement systems for providing horizontal thrust other than those previously defined in the preceding sections shall not be used unless approved by the Engineer

prior to commencement of the work. Consideration for approval will be made on an individual basis for each specified location. The proposed device or system will be evaluated prior to approval or rejection on its potential ability to complete the utility placement satisfactorily without undue stoppage and to maintain line and grade within the tolerances prescribed by the particular conditions of the project.

### 1.21 Submittals

- .1 The Contractor shall submit the following items for review and approval by the Engineer. Approval of the submittal by the Engineer shall be obtained prior to ordering pipe materials and/or the start of the HDD operations.
- .1 **WORK PLAN:** Prior to beginning work, the Contractor must submit to Engineer a work plan detailing the staging area and procedure and schedule to be used to execute the project. The work plan should include a description of all equipment to be used, down-hole tools, a list of personnel and their qualifications and experience personnel and their qualifications and experience (including back-up personnel in the event that an individual is unavailable), list of subcontractors, a schedule of work activity, a safety plan (including MSDS of any potentially hazardous substances to be used), traffic control plan (if applicable), an environmental protection plan and contingency plans for possible problems. Work plan should be comprehensive, realistic and based on actual working conditions for this particular project. Plan should document the thoughtful planning required to successfully complete the project.
- .2 **EQUIPMENT:** Contractor will submit specifications on directional drilling equipment. Equipment shall include but not be limited to: drilling rig, mud system, mud motors (if applicable), down-hole tools, guidance system, rig safety systems. Calibration records for guidance equipment shall be included. Specifications for any drilling fluid additives that Contractor intends to use or might use will be submitted.
- .3 **MATERIAL:** Specifications on material to be used shall be submitted to Engineer. Material shall include the pipe, fittings and any other item, which is to be an installed component of the project.
- .4 Descriptions of methods to control and dispose of ground water, spoil, temporary shoring, and other materials encountered in the maintenance and construction of pits and shafts.

- .5 Shaft dimensions, location, surface construction, profile, depth, method of excavation, shoring, bracing, and thrust block design.
- .6 Pipe design data and specifications.
- .7 A description of the grade and alignment control system.
- .8 Description of lubrication and/or grouting system.
- .9 Layout plans and description of operational sequence.
- .10 Contingency plans for approval for the following potential conditions: damage to pipeline structural integrity and repair; loss and return to line and grade; and loss of ground.
- .11 Procedures to meet all applicable WorkSafeBC requirements. These procedures shall be submitted for a record purpose only and will not be subject to approval by the Engineer. At a minimum, Contractor shall provide the following:
  - a) Protection Equipment.
  - b) Protection against soil instability and ground water inflow.
  - c) Safety for shaft access and exit, including ladders, stairs, walkways, and hoists.
  - d) Protection against mechanical and hydraulic equipment operations, and for lifting and hoisting equipment and material.
  - e) Ventilation and lighting.
  - f) Monitoring for hazardous gases.
  - g) Protection against flooding and means for emergency evacuation.
  - h) Protection of shaft, including traffic barriers, accidental or unauthorized entry, and falling objects.
  - i) Emergency.
  - j) Safety supervising responsibilities.

**1.22 Subsurface  
Conditions**

- .1 All subsurface investigations deemed necessary by the Contractor to complete the work shall be included at no additional cost to the Owner. Copies of all reports and information obtained by the Contractor shall be provided to the owner.
- .2 Unless otherwise specified, all existing surface improvements damaged or removed as a result of drilling operations shall be restored to their original conditions

**1.23 Measurement  
for Payment**

- .1 All units of measurements for payment will be as specified herein unless shown otherwise in Form of Tender. **If not shown in Form of Tender, works are deemed to be incidental to other items of work.**

- .2 Form of Tender describes separate payment items for various sections of pipeline consistent with pipe diameters.
- .3 The unit price per lineal meter for horizontal directional drilling shall include full compensation for grouting and lubricants; providing receiving or recovery shafts including excavation, disposal, dewatering, backfill and replacement of surface or other improvements; furnishing and installing pipe, excavating, and disposal of materials encountered by installation of the pipe; and all other work appurtenant to drilling within the limits described in the Contract Documents.
- .4 Horizontal measurements will be made along the centerline of the pipe. Payment will include supply of all materials, labor and equipment required to perform the installation, mobilization, cleanup, after construction video inspection tapes with logs to Owner's standards and all other work and materials necessary to complete the installation as shown on Contract Drawings and specified herein.
- .5 No separate payment will be made for excavation or pits.
- .6 No separate payment will be made for diverting and pumping around the pipe being installed.

## **PART 2 PRODUCTS**

### **2.1 Pipe**

- .1 All pipe used for horizontal directional drilling shall be:
  - 300mm IPEX FUSABLE BRUTE FUSED-JOINT DR18 PVC PIPE (CIOD). Fusible PVC pipe shall be certified to CSA B137.3 and NSF61 and conform to AWWA C900 or AWWA C905. Testing shall be in accordance with CSA B137.3 and AWWA standards for all pipe types.
- .2 All pipe shall be made of virgin material. No reworked material except that obtained from the manufacturer's own production of the same formulation shall be used
- .3 The pipe shall be homogenous throughout and shall be free of cracks, holes, foreign material, blisters or other deleterious faults.
- .4 Material color shall be blue.
- .5 Damaged pipe shall be removed. Other methods of repairing the damaged conduit may be used, as recommended by the manufacturer and approved by the Engineer.
- .6 The pipe manufacturer's design pipe loads shall not be exceeded during the installation process. The pipe shall be designed to take full account of all temporary installation loads. The pipe materials acceptable for drilling will be specified in the Contract Documents.
- .7 The maximum pulling capacity used shall not exceed the allowable pulling capacity of the pipe that has a minimum factor of safety of 2.0.

### **.1 Compliance**

- .1 Test for compliance with this specification shall be made in accordance with the applicable ASTM Specification. Upon request, a certificate shall be furnished by the manufacturer for all material furnished under this specification. The Contractor shall submit, for approval, the manufacturer's specific technical data with the complete information on resin, physical properties and pipe dimensions pertinent to this project. Polyethylene plastic pipe and fittings will be rejected if they fail to meet any requirements of this specification.

**PART 3 EXECUTION**

**3.1 General:**

- .1 The Contractor shall implement the approved installation plan, and the approved plan submittals to monitor ground movement.
- .2 Codes and Standards. In addition to all codes and standards referenced elsewhere in the Contract Documents, all materials and equipment supplied, and work performed herein shall conform to the latest edition of the applicable industry codes, standards, references and recommended practices listed below. In case of conflict, the requirements of this specification shall prevail.
- .3 The Engineer must be notified 48 hours in advance of starting work. The Directional Bore shall not begin until the Engineer is present at the job site and agrees that proper preparations for the operation have been made.
- .4 The Engineer approval for beginning the installation shall in no way relieve the Contractor of the ultimate responsibility for the satisfactory completion of the work as authorized under the Contract. It shall be the responsibility of Engineer to provide inspection personnel at such times as appropriate without causing undue hardship by reason of delay to the Contractor.
- .5 Existing Facilities and Constraints
  - The Contractor shall be responsible for identifying the specific requirements, features, and constraints that may affect the equipment and procedures used for working around equipment and facilities at this site. The Contractor shall receive no additional compensation for extra work, equipment and expenses incurred in overcoming site constraints and location of buried facilities, including temporary and/or permanent relocation of utilities which may be required to carry out work.
  - The Contractor is responsible for identifying, locating, and confining all utilities (i.e. water lines, overhead and/or below ground power, irrigation, fiber optic and telephone, etc.), as required, along and on either side of the work areas. Unless otherwise instructed, the Contractor shall notify Owners of all the utilities, and shall comply with their requirements. All excavations within 1.5 m of buried utilities shall be performed using manual methods.
- .6 The Contractor shall be responsible for any damage to overhead and underground utilities, roadways, and rail tracks caused by their operations and shall repair and make good the damage at their own expense and in a timely manner.

**3.2 Personnel  
Requirements:**

- .1 All personnel shall be fully trained in their respective duties as part of the directional drilling crew and in safety. Each person must have at least 2 years directional drilling experience. A responsible representative who is thoroughly familiar with the equipment and type work to be performed, must be in direct charge and control of the operation at all times. In all cases the supervisor must be continually present at the job site during the actual directional Bore operation. The Contractor shall have a sufficient number of competent workers on job at all times to ensure the Directional Bore is made in a timely and satisfactory manner.

**3.3 Drilling  
Procedure**

- .1 The Contractor shall carry out clearing, grubbing and stripping, as necessary, and shall create a suitable working area of sufficient dimensions to accommodate the drill rig, mud pits and tanks, mud pumps, and other work site equipment.
- .2 The Contractor shall erect sandbag barriers, or alternative system approved by the Engineer, around the drill rig, mud pumps, mud pits and tanks, and the entry and exit pits. The sandbag barriers shall be a minimum of three (3) layers deep and shall adequately contain any anticipated fluid spillage.
- .3 DRILL PATH SURVEY: Entire drill path shall be accurately surveyed with entry and exit stakes placed in the appropriate locations. If Contractor is using a magnetic guidance system, drill path will be surveyed for any surface magnetic variations or anomalies
- .4 ENVIRONMENTAL PROTECTION: Contractor shall place silt fence between all drilling operations and any drainage, wetland, waterway or other area designated for such protection by contract documents, provincial, federal and local regulations. Additional environmental protection necessary to contain any hydraulic or drilling fluid spills shall be put in place, including berms, liners turbidity curtains and other measures. Contractor shall adhere to all applicable environmental regulations. Fuel may not be stored in bulk containers within 60 meters of any water-body or wetland.
- .5 SAFETY: Contractor shall adhere to all applicable provincial, federal and local safety regulations and all operations shall be conducted in a

safe manner. Safety meetings shall be conducted at least weekly with a written record of attendance and topic submitted to Engineer.

- .6 PIPE: Pipe shall be welded/fused together in one length, if space permits. Engineer may request that welds be X-rayed prior to being placed in bore hole. Pipe will be placed on pipe rollers before pulling into bore hole with rollers spaced close enough to prevent excessive sagging of pipe.

### **3.4 Surface Casing**

- .1 In order to facilitate the HDD installation, a steel surface casing may be required at the entry site, the exit site, or both. The requirement for casings shall be determined by the Contractor, and shall be included in the Contract Price. If required, the casings shall be of large enough diameter to permit the passage of the final hole opener and product pipe.

### **3.5 Directional Drill Hole Alignment and Profile**

- .1 The plan and profile for the pilot hole shall be as shown on the Drawings. An alternate drill path may be designed by the Contractor. The Contractor's design shall meet the criteria for the entry and exit angles specified herein in order to match the tie-in connections at the entry and exit locations.
- .2 if an alternate drill path is proposed, it shall be submitted with supporting pulling loads and pipe stress calculations to the Engineer for approval. The Contractor's proposed drill path will be reviewed by the Engineer. The Engineer's decision on acceptability of any alternative shall be final. The Engineer's acceptance of the Contractor's proposal shall be with respect to general installation and operating considerations only, and shall not be construed in any way as relieving the Contractor of any of their obligations under the Contract.
- .3 The final plan and profile for the pilot hole shall be designed by the Contractor within the following constraints, unless prior written approval is obtained from the Engineer for variances.
- .4 The tightest compound radius of the directional drilling trajectory shall be not less 100 meters, or as otherwise shown on design drawings as governed by drill rod or pipe minimum bending radius. The drilled radius shall be calculated over any three-joint segment.



- 
- .5 The planned pipe alignment shall be centered within the identified right-of-ways and/or land leases.
- .6 The excavation for the drill entry and exit pits, and selection and any regarding of the pipe lay-down area, shall be developed to avoid a sudden radius change of the pipe, and consequent excessive deformation at these locations.
- 3.6 Joining PVC Pipe** .1 The PVC Fusion contractor must be identified in the tender documents and the Fusion Technician shall be fully qualified by IPEX to fuse fusible PVC Pipe of the type(s) and size(s) being used. Qualification shall be current as of the actual date of the tender and of fusion on the project.
- 3.7 Directional Drill Hole Control** .1 The Contractor shall utilize an approved surface tracking system and a downhole steering system to monitor the position of the drill string and compute the position in the x,y, and z axes relative to ground surface a minimum of once per length of drill pipe drilled (every 10m). Deviations between the recorded position of the drill string and the specified position of the drill string shall be documented and immediately brought to the attention of the Engineer.
- .2 The Engineer shall have access to the Contractor's down hole survey and data at all times and shall be provided with an as-built copy upon completion of the pilot hole.
- 3.8 Directional Drill Hole Vertical and Horizontal Tolerances** .1 The required directional tolerances are critical to facilitate the ultimate objective of installing the pipe as specified. The Contractor shall therefore maintain directional control at all times during pilot hole drilling within the following tolerances:
- .2 VERTICAL TOLERANCES: +/- 75 mm from the centerline of the planned drill path profile.
- .3 HORIZONTAL TOLERANCES: within right-of-ways, and maximum +0.5 meters or -0.5 meters from the centerline of the planned drill path plan alignment.
- .4 ENTRY POINT LOCATION: It is envisaged that the pilot hole will enter the ground from the entry point as shown on the Drawings. The Contractor may propose an alternate configuration, but this will be subject to review by the Engineer and other affected parties for changes and acceptability. And may not be accepted. The Engineer's

decision in regard to alternate entry point locations will be final. Should the Contractor's alternate proposal not be accepted, they shall locate the entry point as shown on the Drawings, and carry out the work for the agreed Contract Price and schedule, without any additional cost to the Owner

- .5 CURVE RADIUS: The Contractor shall ensure that the maximum degree of deviation, or "dog-leg", in the pilot hole is less than 4.0 degrees or less over any 3 joint segments measured by the minimum curvature method. In the event of any deviation exceeding 2.0 degrees, the Contractor shall pullback the re-drills to meet the specifications at the Contractor's cost. If necessary, the Contractor shall plug back with cement in order to re-drills to meet the specifications at the Contractor's cost. If necessary, the Contractor shall plug back with cement in order to re-drill any portion of the hole to meet these criteria at the Contractor's cost.
- .6 At the completion of pilot hole drilling, the Contractor shall provide to the Engineer an as-built drawing drawn in AutoCAD 2010 or higher format and tabulation that defines and locates the coordinates of the drilled hole throughout its length. This shall include a copy of survey data.
- .7 All welding by Contractor or surface casing shall be in accordance with CSA Z622-96 specifications and shall likewise be x-rayed by the Contractor if desired by the Engineer.
- .8 Pilot hole shall be drilled on bore path with no deviations greater than 5% of depth over a length of 30 meters. In the event that pilot does deviate from bore path more than 5% of depth in 30 meters, contractor will notify Engineer and Engineer may require contractor to pull-back and re-drill from the location along bore path before the deviation. In the event that a drilling fluid fracture, inadvertent returns or returns loss occurs during pilot hole drilling operations, contractor shall cease drilling, wait at least 30 minutes, inject a quantity of drilling fluid with a viscosity exceeding 120 seconds as measured by a March funnel and then wait another 30 minutes.

If mud fracture or returns loss continues, contractor will cease operations and notify Engineer, Engineer and contractor will discuss additional options and work will then proceed accordingly.

- .9 HOLE EXIT LOCATION. The Contractor shall obtain written confirmation from the Engineer that the actual exit location is within the specified tolerances prior to reaming. If necessary, the Contractor

shall plug back with cement grout and re-drill pilot hole to exit within the specified tolerances.

- .10 REAMING: Upon successful completion of pilot hole, contractor will ream bore hole to 25% to 50% (depending on ground conditions) greater than outside diameter of pipe using the appropriate tools. Contractor will not attempt to ream at one time more than the drilling equipment and mud system are designed to safely handle.
- .11 DRILLING FLUID CONTROL. The Contractor shall carry out the work in such a manner as to minimize the possibility of drilling fluid loss to the environment, or break outs of drilling fluid to surface.
- .12 PIPE STRINGING, FABRICATION AND PRE-TESTING OF WATER MAIN. The Contractor shall string the fabricate the pipe in sufficient length such that any elastic strain recover in the pipe after pull back can be accommodated for and that installation is completed as shown on the drawings. Depending on the scheduling and approach to the work, it may not be possible to assemble the pipes in one continuous length for pulling. Prior to pull back, each section of pipe shall be pressure tested as specified unless specified otherwise.
- .13 PULL-BACK: Immediately upon completion of the cleaning pass(es) the Contractor shall, as soon as possible, rig up and commence the pull back operations. The pullback operation shall be continuous without interruption until completed, except for planned intermediate pipe joints. The Contractor shall have on hand sufficient labor and equipment to minimize the length of time taken for making the pipe joints.

Pipe pull back length shall be determined to ensure that tensile pull stresses of the pipe are not exceeded.

The pull section shall be supported with cranes, side booms and pipe rollers as it proceeds during pull back so that it moves freely without damaging the pipe or any coating.

Cranes or extended side booms shall be used where necessary to provide sufficient clearance over roadways, railway and access roads to allow safe uninterrupted traffic during the entire pull back operations.

The Contractor shall, at their expense, provide equipment to continuously monitor the pulling forces during the pull back operations.

A record indicating break out force and average pull force for each drill stem shall be kept along with the start and stop times.

The Contractor shall pull a sufficient length of pipe such that any elastic strain recovery in the pipe after pull-back can be accommodated for, and that the ends of the pipe are terminated at the specified elevations in preparation for the tie-in connections at the entry and exit points as per the drawings.

The Contractor is responsible for any damage to the pipe during the work. The Engineer will inspect the first 10 meters of pipe coming out of the hole on the rig side for any damage and if damage is observed, the Contractor will be required to submit a plan to the Engineer outlining proposed remedial measures and then implement the remedial measures, at the Contractors expense.

- .15 BUOYANCY CONTROL: The Contractor shall make provisions for buoyancy control during the pull back operations. The weight of the pipe and contents shall be controlled as it is pulled through the hole to minimize the pulling forces, and maintain them within the specified pipe tolerances and those established by the Contractor in their design.

After successfully reaming bore hole to the required diameter, contractor will pull the pipe through the bore hole. In front of the pipe will be swivel and reamer to compact bore hole walls. Once pullback operations have commenced, operations must continue without interruption until pipe is completely pulled into the borehole. During pullback operations contractor will not apply more than the maximum safe pipe pull pressures at any time. In the event that pipe becomes stuck, contractor will cease pulling operations to allow any potential hydro-lock to subside before re-commencing pulling operations. If pipe remains stuck, contractor will notify Engineer. Engineer and contractor will discuss options and then work will proceed accordingly.

Once the hole has been reamed to full diameter, the Contractor shall pull back the water main and insert into the reamed hole. The Contractor shall ensure the ends of the sanitary sewer main are terminated at the specified elevations in preparation for the tie-in connections at the entry and exit points as per drawings.

The Contractor shall ensure that during the pull back of the pipe, that the pipe is hydrostatically sealed so as to prevent ingress of any material into the pipeline.

Upon completion of installation, the Contractor shall conduct final hydrostatic pressure tests on the fully water main.

The Contractor shall be responsible for the supply and disposal of test water from the designated source, subject to the specifications included herein, and any other applicable regulatory requirements

**3.10 Site  
Restoration**

- .1 Following drilling operations, contractor will de-mobilize equipment and restore the work-site to original or better condition. All excavations will be backfilled and compacted to 95% of original density.

### **2.3 Service Connections**

Add: .11 Inspection Chambers to be installed as per City Supplement Standard Drawing SAN-6 and lids shall be coloured red.

### **2.4 Concrete**

Replace: .2 Concrete to be a minimum compressive strength of 25mPa at 28 days.

### **2.5 Granular Pipe Bedding and Surround Material**

Add: .3 Trench dams as specified on the contract drawings.

### **3.6 Pipe Installation**

Replace: .3 Horizontal tolerances: plus or minus 10 mm from specified alignment;  
Vertical tolerances: plus or minus 5 mm from specified grade. Reverse grade is not acceptable

Replace: .6 Joint and Pipe deflection not permitted unless otherwise approved by the City Engineer.

---

## **PART 1 GENERAL**

### **1.1 General**

- .1 The works specified in the section consists of furnishing and installing underground utilities using the manual relining method of installation. This work shall include all services, equipment, materials, and labor for the complete and utilities and environmental protection and restoration.
- .2 This section must be referenced to and interpreted simultaneously with all other sections pertinent to the works described herein.

### **1.2 Related Work**

- |    |  |                  |
|----|--|------------------|
| .1 | Traffic Control, Vehicle Access, and Parking | Section 01 55 00 |
| .2 | Excavating, Trenching, and Backfilling       | Section 31 23 01 |
| .3 | Trenchless Sewer Pipe Bursting               | Section 33 05 23 |
| .4 | Cured in Place Pipe Liners                   | Section 33 05 24 |
| .5 | Sanitary Sewer                               | Section 33 30 01 |
| .6 | Manholes & Catchbasins                       | Section 33 44 01 |

### **1.3 Definitions**

- .1 Outside Diameter— (OD) The average measured distance in a straight line from one point on the outer wall of the pipe, through its center, to an opposite point also on the outside of the pipe.
- .2 Inside Diameter— (ID) The average measured distance in a straight line from one point on the inner wall of the pipe, through its center, to an opposite point also on the inside of the pipe.

### **1.4 Quality Assurance**

- .1 The Contractor shall, at their expense, provide equipment to continuously monitor the pulling forces during the pipe pull through pulling operations.
- .2 The Contractor shall pull a sufficient length of pipe such that any elastic strain recovery in the pipe after pull-back can be accommodated for, and that the ends of the pipe are terminated at the specified elevations in preparation for the tie-in connections at the entry and exit points as per the contract drawings.
- .3 The Contractor is responsible for any damage to the pipe during the work. All remedial works are to be at the Contractors expense.
- .4 In the event that pipe becomes stuck, the contractor will cease pulling operations to allow any potential hydro-lock to subside before re-commencing pulling operations. If pipe remains stuck, contractor will notify the Engineer. Engineer and contractor will discuss options and then work will proceed accordingly.
- .5 The Contractor shall submit for approval the following information to the Contract Administrator for each manhole-to-manhole section at least seven (7) days prior to the commencement of any work:
  - .1 Proposed sequence of construction.
  - .2 Location and dimensions of entry and exist pits including staging areas and pipe storage areas.

- .3 Method of dewatering including disposal (if required).
- .4 Bypass pumping arrangement (if required).
- .5 Method of pulling and description equipment.
- .6 Copy of certificate for fusion equipment operator listing fusion training and training organization.
- .7 HDPE pipe manufacturer's recommended fusion procedures including point interfacial pressures and heater temperature.
- .8 Maintenance records and pressure gauge calibration for fusion machine.
- .9 Maximum permissible tensile forces on HDPE.
- .10 Details of selected lubrication product.
- .11 Traffic management plan.
- .12 Safety procedures and certificate of satisfactory first aid training.
- .13 Sediment and lubrication control details.
- .14 Schedule of expected interruptions and reconnect time.
- .15 Method of construction and restoration of existing sewer to services and manhole connections.

### 1.5 Codes and Standards

- .1 In addition to all codes and standards referenced elsewhere in the Contract Documents, all materials and equipment supplied and work performed herein shall conform to the latest edition of the applicable industry codes, standards, references and recommended practices listed below. In case of conflict, the requirements of this specification shall prevail.
  - ASTM F-714: Standard Specification for Polyethylene (PE) Plastic Pipe (SDR-PR). Based on outside diameter.
  - ASTM D-1248: Standard Specification for Polyethylene Plastics Molding and extrusion Materials.
  - ASTM D-3350: Standard Specification for Polyethylene Plastics Pipe and Fittings Materials. CSA B137.1: Polyethylene Pipe Tubing and Fittings for Cold Water Pressure Services.
  - ASTM D-3505: Standard Specification for Polyethylene (PE) Plastic Pipe (SDR-PR). Based on Controlled Outside Diameter.
  - ISO 9002: Model for Quality Assurance in Production and Installation.
  - ASTM D-2657: Heat Joining Polyolefin Pipe and Fittings.

### 1.6 Materials Supplied by the Owner

- .1 The Owner will provide the Right of Way for the work and the Work and Storage Areas.
- .2 The Owner will provide water at a source near the site. The Contractor shall provide an approved valve through which they can draw water. The hydrant valve and/or hydrant shall not be used to control water. The hydrant shall be securely closed when no work is actively being carried out. Water shall not be wasted; if it is, the Engineer may terminate the supply and the Contractor shall then be responsible for obtaining water elsewhere.

### 1.7 Mobilization



- .1 Mobilization for the works covered by this Specification shall include the assembly and transportation to the works Site of all equipment, materials and personnel necessary to perform the Work. This shall include, but not be limited to the following items:
  - Relining materials
  - Relining Equipment
  - Grouting equipment
  - Procurement of all permits and licenses for the execution of the Works, except for those obtained by the Owner; and Approval by the Engineer of all preconstruction submittals required by this Specification.
- .2 Mobilization and site preparation shall not be considered complete until the above equipment has been completely rigged up and in position at the site and ready to commence work.

### **1.8 Right of Way and Work and Storage Area**

- .1 The contractor is responsible for abiding to both City of Salmon Arm and Ministry of Transportation and Infrastructure bylaws, regulations or as otherwise outlined in subsequent permits. The Contractor is advised that all operations must be strictly confined to the areas identified unless they obtain specific permission.
- .2 The Contractor shall familiarize themselves with the layout areas and make such allowances as may be necessary for any stops and intermediate welds. Any additional working space required by the Contractor for such uses as pipe(s) layout, Storage of spoil material, equipment turnarounds, vehicle servicing and fueling yards, access to the right-of-way and other requirements shall be obtained by the Contractor at the Contractor's expense and such agreements shall meet the Owner's requirements. The Contractor shall provide a copy of all such agreements made with the occupants to the Owner prior to the use of the additional work areas covered by those agreements.
- .3 The pipe shall be installed to the alignment and elevation shown on the drawings unless approved otherwise. The Owner shall have the right to make any changes necessary in the location of the proposed sanitary sewer or appurtenances, and if the change results in increasing or decreasing the cost of the Contractor in comparison with what its cost would have been had no change been made, the Contract Price will be equitably adjusted.

### **1.9 Access**

- .1 Access to the site shall be through the existing Municipal Road ways and Right of ways in accordance with the Contract Documents. The Contractor shall provide cleared work areas at the entry and exit sites, and shall ensure suitably dry working conditions.
- .2 Except as specifically noted herein, uninterrupted vehicle traffic movement shall be maintained at all times on all public roads and private access points. The Contractor shall identify within their work plan the proposed site preparation work, equipment, and procedures to satisfy this requirement. The Contractor shall be responsible for all traffic control and obtaining traffic control permits and carrying out their requirements if necessary.
- .3 When its operations are conflicting with normal traffic, the Contractor shall provide suitable detours, at the discretion of the Owner. All detours shall be clearly marked

to the satisfaction of the Engineer. The Contractor shall furnish and maintain all necessary day and night warning signs, flares lanterns, barricades and flagmen when working on near roads, highways, or traffic ways, to protect all persons from injury and property from damage, and to warn the drivers of vehicles of the obstruction.

### 1.10 Measurement and Payment

- .1 All units of measurement for payment will be as specified herein unless shown otherwise in Form of Tender. If not shown in Form of Tender, works are deemed to be incidental to other items of work.
- .2 Measurement for payment for sewer relining will be made in lineal meters for each payment item described in Form of Tender.
- .3 Measurement for payment for sewer relining will be made based on center to center distances between manholes as measured in the field by Engineer's Inspector and verified by the Contractor. An amount totaling 10% of agreed length will be withheld from payment until final post lining and post sealing CCTV inspection reports have been received and reviewed for acceptance by the Engineer. CCTV inspection reports must be received by the Engineer no later than two (2) weeks after completion of works.

### 2.1 Pipe

- .1 All pipe used for horizontal directional drilling shall be:
  - 175mm High Density Polyethylene (HDPE) DR 32.5.
- .2 All pipe shall be made of virgin material. No reworked material except that obtained from the manufacturer's own production of the same formulation shall be used.
- .3 The pipe shall be homogenous throughout and shall be free of cracks, holes, foreign material, blisters or other deleterious faults.
- .4 Material color shall be black.
- .5 Damaged pipe shall be removed. Other methods of repairing the damaged conduit may be used, as recommended by the manufacturer and approved by the Engineer.
- .6 The pipe manufacturer's design pipe loads shall not be exceeded during the installation process. The pipe shall be designed to take full account of all temporary installation loads. The pipe materials acceptable for relining will be specified in the Contract Documents.
- .7 The maximum pulling capacity used shall not exceed the allowable pulling capacity of the pipe that has a minimum factor of safety of 2.0.

### 3.1 Joining Polyethylene Pipe

- .1 Polyethylene pipe shall be joined by thermal butt fusion in accordance with ASTM D2657 and as recommended by the pipe manufacturer. The temperature of the heater plate shall not exceed 210°C +/-5°C, 410°F +/-10°F, and the joining pressure shall not exceed 172 kpa, 25psi of projected end area excluding an allowance for friction.
- .2 Polyethylene pipe shall be joined to other systems by means of an assembly consisting of polyethylene stub end, but fused to pipe, a backup flange of ductile iron in accordance with ANSE B16.11 B16.5 modified as recommended by pipe

supplier. 316 Stainless steel bolts, and neoprene or red rubber gasket cut to fit the joint. Care shall be taken to draw up the butts uniformly.

### 3.2 Pipe Installation

- .1 The Contractor shall be responsible for the installation of the pipe and all associated work unless specified otherwise. The method of installation will depend on the type of liner used. The handling and installation of the pipe shall be in accordance with the manufacturer's specifications.
- .2 Line obstructions:
  - .1 The Contractor shall be responsible for clearing any line obstructions such as solids, protruding connections, broken pipe or roots that will prevent the insertion of the liner. If inspection reveals an obstruction that cannot be removed by 'no dig' techniques, the Owner will make a point excavation to uncover, remove or repair the obstruction.
  - .2 The Contractor will not be reimbursed for damages or lost time while the Owner completes the point excavation and repair.
  - .3 Complete CCTV inspection before liner installation in accordance with Specification 33 01 30.1, submit pre-lining inspection recording / DVD and report to Contract Administrator with post-lining final inspection recording / DVD and reports.
- .3 The finished pipe shall be continuous over the entire length on an insertion run and shall be free from visual defects such as foreign inclusions, dry spots, pinholes and delamination.
- .4 The pipe ends in the manhole shall be tight fitting and shall require application of a watertight sealing product at the terminal points. The sealing product shall be compatible with the pipe. Any lip or obstruction created by the pipe shall be gently tapered. The liner ends shall not obstruct sewerage flow.

**END OF SECTION**

## 2.6 Service Connections

- Replace: .1 Storm sewer service connections to be 150 mm minimum diameter; maximum diameter as specified on the Contract Drawings.
- Replace: .2 Storm sewer service connections 150 mm diameter to be PVC type PSM DR 28 sewer pipe.
- Add: .11 Inspection Chambers to be installed as per City Supplement Standard Drawing ST-6 and lids shall be coloured green.

## 2.8 Concrete

- Replace: .2 Concrete to be a minimum compressive strength of 25mPa at 28 days.

## 2.9 Granular Pipe Bedding and Surround Material

- Add: .3 Trench dams as specified on the contract drawings.

## 3.6 Pipe Installation

- Replace: .3 Horizontal tolerances: plus or minus 20 mm from specified alignment;  
Vertical tolerances: plus or minus 10 mm from specified grade. Reverse grade is not acceptable
- Replace: .6 Joint and Pipe deflection not permitted unless otherwise approved by the City Engineer.

## 2.1 Materials

- Add: .7.4 Cover must be labelled with the appropriate utility: “SANITARY”, “STORM”, or “WATER”.
- Add: .24 Fiberglass Manhole Liners
- .1 Fibreglass manhole liners shall be one piece consisting of unlayered homogeneous fibreglass reinforced plastic with full flow channels with side walls to crown of pipe, watertight gasketed bells graded and aligned to comply with design to suit specified pipe, inner surface of liner benching to have anti skid surface, outer surface of liner to be sand coated and to have sufficient steel spirals bonded to the fibreglass reinforced plastic to assure a continuous physical connection to the concrete base.
  - .2 Pre benched manhole fibreglass reinforced plastic liners as specified on the contract drawings and in accordance with the Manufacturer’s specifications.
- Add: .25 Trapping Hoods: All catchbasin leads to be supplied with trapping hoods within the catchbasin which shall be 200mm diameter aluminum.
- Add: .26 Orifice Control Devices shall be installed as per approved engineering drawings.

# Subdivision and Development Servicing Bylaw No. 4293

## Schedule “C”



## CITY OF SALMON ARM

## FORMS

## **CONTENTS**

F-1	Permission to Construct
F-2	Certificate of Inspection
F-3	Certificate of Inspection – Strata Subdivision
F-4	Certificate of Substantial Completion
F-5	Certificate of Completion
F-6	Certificate of Final Acceptance
F-7	Private Well Certification
F-8	Professional Assurance Certificate
F-9	Form of Letter of Credit
F-10	Hydrant Flow Test Report Form (Available in Excel format from CSA)
F-11	Flushing / Testing / Disinfection Report



## PERMISSION TO CONSTRUCT

Authorization to proceed with construction is hereby granted to:

NAME OF DEVELOPER:

ADDRESS:

For the works described generally as:

---

---

---

Authorized Start Date:

Estimated Completion Date:

Check the following:

- Construction plans approved
- Certificates of insurance received
- Waterworks Construction Permit (provided by Interior Health Authority)
- Security deposit has been paid
- A Servicing Agreement has been completed – No. \_\_\_\_\_
- Latecomer Waiver/Agreement adopted

Design Engineer	
Contact:	
Business Tel:	
Special Conditions:	

\_\_\_\_\_  
CITY ENGINEER

c.c. Contractor

File No: \_\_\_\_\_





## CERTIFICATE OF INSPECTION

I hereby certify that all engineering and construction services, required under Subdivision and Development Servicing Bylaw No. 4163 of the City of Salmon Arm for the subdivision of:

LEGAL DESCRIPTION: \_\_\_\_\_

PROJECT NO: \_\_\_\_\_

Which services were designed by:

NAME OF FIRM: \_\_\_\_\_

ADDRESS: \_\_\_\_\_

And approved for construction on drawing numbers:

Drawing No.	Date	Drawing No.	Date
_____	_____	_____	_____
_____	_____	_____	_____
_____	_____	_____	_____
_____	_____	_____	_____
_____	_____	_____	_____
_____	_____	_____	_____

Have been inspected by or under the direction of:

\_\_\_\_\_  
\_\_\_\_\_

I further certify that the "Record Drawings" hereby submitted represent the works and services as installed for the aforementioned subdivision.

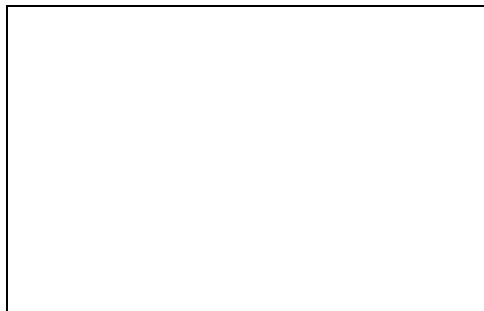

Engineer's Seal

\_\_\_\_\_  
\_\_\_\_\_

Signature and name of the Professional  
Engineer responsible for Design



## CERTIFICATE OF INSPECTION STRATA SUBDIVISION

I hereby certify that all engineering and construction services, required under Subdivision and Development Servicing Bylaw No. 4163 of the City of Salmon Arm and/or good engineering practice for the strata subdivision of:

LEGAL DESCRIPTION: \_\_\_\_\_

PROJECT NO: \_\_\_\_\_

Which services were designed by:

NAME OF FIRM: \_\_\_\_\_

ADDRESS: \_\_\_\_\_

And approved for construction on drawing numbers:

Drawing No.	Date	Drawing No.	Date
_____	_____	_____	_____
_____	_____	_____	_____
_____	_____	_____	_____
_____	_____	_____	_____
_____	_____	_____	_____
_____	_____	_____	_____

Have been inspected by or under the direction of:

\_\_\_\_\_  
\_\_\_\_\_

I further certify that the “Record Drawings” hereby submitted represent the works and services as installed for the aforementioned subdivision.

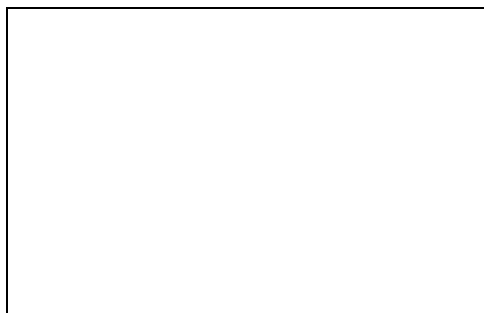

Engineer's Seal

\_\_\_\_\_  
\_\_\_\_\_

Signature and name of the Professional  
Engineer responsible for Design



# CERTIFICATE OF SUBSTANTIAL COMPLETION

DEVELOPER: \_\_\_\_\_

CONTRACTOR: \_\_\_\_\_

PROJECT NO: \_\_\_\_\_

FILE NO: \_\_\_\_\_

SERVICING AGREEMENT NO: \_\_\_\_\_

DATE: \_\_\_\_\_

This certificate is issued pursuant to Schedule “B”, Part 1, of Subdivision and Development Servicing Bylaw No. 4163 and applies to the following Works and Services:

- |                                 |                          |                       |                          |
|---------------------------------|--------------------------|-----------------------|--------------------------|
| Roads and Civil Works           | <input type="checkbox"/> | Sanitary Sewer System | <input type="checkbox"/> |
| Drainage and Storm Sewer System | <input type="checkbox"/> | Waterworks System     | <input type="checkbox"/> |

The **MAINTENANCE PERIOD** of \_\_\_ year(s) for the Works & Services will begin on \_\_\_\_\_.

Maintenance Bonding in the amount of \$\_\_\_\_\_ has been received and will be returned upon Final Acceptance.

The Certificate of Completion will be issued when all deficiencies have been corrected. The Certificate of Final Acceptance will be issued when the maintenance period expires and all deficiencies that have arisen over the year have been corrected, and the City Engineer has been satisfied all conditions of the Servicing Agreement have been fulfilled.

This Certificate has been made to the best of the City Engineer’s knowledge, information and belief. It does not constitute acceptance of any work not in accordance with the requirements of Subdivision and Development Servicing Bylaw No. 4163, and not listed as a deficiency herein, whether or not such defect(s) could have been observed or discovered during construction.

The following is a **LIST OF DEFICIENCIES** related to the Work:

_____	_____
_____	_____
_____	_____
_____	_____
_____	_____
_____	_____

\_\_\_\_\_  
City Engineer



## CERTIFICATE OF COMPLETION

DEVELOPER: \_\_\_\_\_  
CONTRACTOR: \_\_\_\_\_  
PROJECT: \_\_\_\_\_  
FILE NO: \_\_\_\_\_  
LOCATION: \_\_\_\_\_  
DATE: \_\_\_\_\_

The final construction inspection was held on \_\_\_\_\_ and all deficient items have been addressed to City satisfaction.

I \_\_\_\_\_, Consulting Engineer of \_\_\_\_\_ hereby certify that all works reflect City of Salmon Arm standards and specifications, and that all works have been completed in accordance with the approved construction plans.

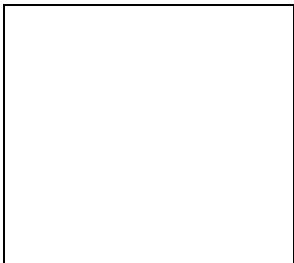

SEAL

\_\_\_\_\_  
Consulting Engineer

The City of Salmon Arm's acknowledgement of this certificate does not represent acceptance of the work, nor shall this act by the City of Salmon Arm prejudice any requirements of the agreement with the contractor, nor operate to relieve the contractor of any of his/her responsibilities thereunder.

\_\_\_\_\_  
City of Salmon Arm



## CERTIFICATE OF FINAL ACCEPTANCE

DEVELOPER: \_\_\_\_\_  
CONTRACTOR: \_\_\_\_\_  
PROJECT NO: \_\_\_\_\_  
FILE NO: \_\_\_\_\_  
SERVICING AGREEMENT NO: \_\_\_\_\_  
DATE: \_\_\_\_\_

All deficiencies, defects or faults in the Work observed or discovered within the period preceding the date of this Certificate having been rectified, this Certificate is issued pursuant to the referenced Servicing Agreement.

This Certificate has been made to the best of the City Engineer's knowledge, information and belief. It does not constitute acceptance of any work not in accordance with the requirements of the Servicing Agreement, whether or not such defect(s) could have been observed or discovered during construction.

This certificate permits the release of the project maintenance security in the amount of \$\_\_\_\_\_.

\_\_\_\_\_  
City Engineer

c.c. Contractor  
Developer



## PRIVATE WELL CERTIFICATION

Pursuant the Subdivision and Development Servicing Bylaw No. 4163 which requires that each lot to be created and/or each existing lot forming part of the proposed development can be serviced with potable water in accordance with the requirements of the Bylaw for the development of:

LEGAL DESCRIPTION: \_\_\_\_\_

PROJECT NO: \_\_\_\_\_

I certify that a quantity of not less than 2,500 litres per day on a year round basis has been proven for each existing or proposed lot in the development.

I certify that each well within the subdivision has been tested and is capable of continuously providing water at a rate of 9 litres per minute for a four hour period.

I certify that water quality tests have been conducted and that the “Canadian Drinking Water Standards, 1996, as amended” can be met for each existing or proposed lot in the development.

Certified by:

\_\_\_\_\_

Signature and Name of Professional Engineer  
or Qualified Well Driller (where applicable)

\_\_\_\_\_

\_\_\_\_\_

Address

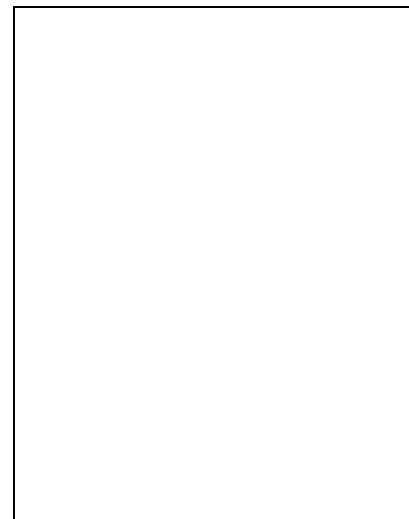

Engineer's Seal  
(where applicable)

(on company letterhead)

## “PROFESSIONAL ASSURANCE CERTIFICATE”

The City of Salmon Arm  
PO Box 40  
Salmon Arm, BC  
V1E 4N2

Attention: City Engineer

Dear Sir:

**RE: NAME OF SUBDIVISION OR DEVELOPMENT AND ADDRESS**

---

I, (*Owner's Name*) have retained (*Consultant's Name*) as my/our Professional Engineer (*“Consultant”*), to undertake and/or co-ordinate and review all associated design criteria and “field reviews” required for this project. It is understood that my “Consultant” will take all such steps as regulated under the Provincial Statute for his/her profession and by the definition of “field reviews” herein under set forth, to ascertain that the design will comply and construction of the project will substantially conform in all material respects with the provisions of the City of Salmon Arm’s Subdivision and Development Servicing Bylaw No. 4163, all other amendment thereof, and other applicable permits, Bylaws, Acts and regulations which apply to this project. My “Consultant” will also ensure that all work is completed in accordance with the construction drawings approved by the City of Salmon Arm. My consultant will ascertain that only qualified personnel are retained to carry out tests, inspect or carry out design work and detailing “field reviews”.

As used herein, “field review” shall mean such reviews of the work at the project site at the fabrication locations, where applicable, as the “Consultant”, in his/her professional discretion, considers necessary in order to ascertain that the work substantially conforms in all material respects to the plans and supporting documents “accepted” by the City of Salmon Arm. This will include keeping records of all site visits and any corrective actions taken as a result thereof.

The undersigned has given a contractual mandate to the “Consultant” to review reports of other testing and inspection agencies and disciplines where necessary, comment on their acceptability, determine the corrective action to take if unacceptable, and maintain a detailed record of every such report and comments thereof. The “Consultant” will automatically submit a monthly summary progress report to the City Engineer, including all field report and change orders.

Note:

The owner will notify the City Engineer in writing thirty (30) days prior to the intended termination of or by the "Consultant". It is understood that the work on the above-project will cease as of the effective date of termination, until such time as a new appointment is made.

\_\_\_\_\_  
Witness Name (Print)

\_\_\_\_\_  
Owner's Name (Print)

\_\_\_\_\_  
Witness Signature

\_\_\_\_\_  
(Owner or Owner's Appointed  
Agents Signature)

\_\_\_\_\_  
Address (Print)

\_\_\_\_\_  
Date

\_\_\_\_\_  
Occupation

\_\_\_\_\_  
Title of Agent (if applicable)

\_\_\_\_\_  
Address (Print)

\_\_\_\_\_  
The Corporate Seal of

\_\_\_\_\_  
was hereunto affixed in the presence of:

\_\_\_\_\_

\_\_\_\_\_

The above must be signed by the Owner or his/her appointed Agent. The signature must be witnessed. If the Owner is a company, the corporate seal of the company must be affixed to the document in the presence of its duly authorized officers. The officers must also sign, setting forth their positions in the company.



This “Consultant” acknowledges that he/she has been retained to ascertain that the design will comply and construction of the project will substantially conform in all material respects with the Bylaws as set out above and will submit letter of Professional Design Assurances from others, as needed, for the approval of the subdivision or development. Furthermore, the “Consultant” hereby covenants that their firm presently carries liability insurance in the amount of \_\_\_\_\_.

My “Consultant” will upon completion of the work provide “CERTIFICATE OF INSPECTION” (Form F-2). My “Consultant” will further provide upon completion all supporting documentation required by the City of Salmon Arm to verify conformance of the work.

\_\_\_\_\_  
Name of Professional (Print)

\_\_\_\_\_  
Signature of Professional

\_\_\_\_\_  
Date

\_\_\_\_\_  
Mailing Address (Print)

\_\_\_\_\_  
Phone

FORM OF LETTER OF CREDIT  
(TO BE ON BANK LETTERHEAD)

Letter of Credit No.: \_\_\_\_\_

Amount \$ \_\_\_\_\_

Initial Expiry Date: \_\_\_\_\_

CITY OF SALMON ARM  
500 - 2 AVENUE NE  
BOX 40  
SALMON ARM BC V1E 4N2

WE HEREBY AUTHORIZE YOU TO DRAW ON THE (name and address of bank) for the account of (name of Developer/Contractor) UP TO AN AGGREGATE AMOUNT OF (dollars in writing and in numbers) available on demand.

PURSUANT TO THE REQUEST OF our customer, (name of Developer/Contractor), we the (name of bank) hereby establish and give you an Irrevocable Letter of Credit in your favour in the above amount which may be drawn on by you at any time and from time to time, upon written demand for payment made upon us by you, which demand we shall honour without enquiring whether you have the right as between yourself and the said customer to make such demand, and without recognizing any claim or our said customer, or objection by it to payment by us.

THE LETTER OF CREDIT we understand relates to those services and financial obligations set out in an agreement between the customer and the CITY OF SALMON ARM and referred to as (description of agreement and works covered).

THIS LETTER OF CREDIT will continue in force for a period of one year, but shall be subject to the condition hereinafter set forth.

IT IS A CONDITION of this Letter of Credit that it shall be deemed to be automatically extended without amendment from year to year from the present or any future expiration date hereof, unless at least 30 days prior to the present or any future expiration date, we notify you in writing by registered mail that we elect not to consider this Letter of Credit to be renewable for any additional period.

DATED at \_\_\_\_\_, British Columbia this \_\_\_\_\_ day of \_\_\_\_\_, \_\_\_\_\_

COUNTERSIGNED BY:

\_\_\_\_\_  
(name of bank)

per:

\_\_\_\_\_

\_\_\_\_\_



CITY OF SALMON ARM  
 ENGINEERING DEPARTMENT

# HYDRANT FLOW TEST

**TEST DATE:** \_\_\_\_\_

**COMPLETED BY:** \_\_\_\_\_

**TEST TIME:** \_\_\_\_\_

**GAUGE HYDRANT:**

**Flow Test # 1**

**Flow Test # 2**

HYDRANT NUMBER: \_\_\_\_\_ MAKE & MODEL: \_\_\_\_\_ MAIN SIZE: \_\_\_\_\_

HYDRANT LOCATION: \_\_\_\_\_ VALVE LOCATION: \_\_\_\_\_

STATIC PRESSURE: \_\_\_\_\_ psi      ▼ 0 psi  
 RESIDUAL PRESSURE: \_\_\_\_\_ psi      \_\_\_\_\_ psi

**FLOW HYDRANT:**

**Flow Test # 1**

**Flow Test # 2**

HYDRANT NUMBER: \_\_\_\_\_ MAKE & MODEL: \_\_\_\_\_ MAIN SIZE: \_\_\_\_\_

HYDRANT LOCATION: \_\_\_\_\_ VALVE LOCATION: \_\_\_\_\_

STATIC PRESSURE: \_\_\_\_\_ psi      ▼ 0 psi  
 PITOT GAUGE READING (PRESSURE): \_\_\_\_\_ psi      \_\_\_\_\_ psi  
 FLOW OPENING DIAMETER: 2.5 inches      2.5 inches  
 NUMBER OF PORTS OPEN: 1 ports      2 ports

NFPA Section 2.3 : DROP IN PRESSURE > 25% FOR VALID TEST      ▼ #DIV/0!      ▼ #DIV/0!

**FLOW CALCULATIONS**

$G = 24.84 \cdot D^{2.45} \cdot C \cdot P^{0.54}$

G = FLOW IN igpm

D = NOZZLE DIAMETER IN inches

P = PITOT GAUGE READING IN psi

C = COEFFICIENT (USUALLY 0.9 FOR FULL FLOW)

$Q(r) = Q(f) \cdot (H(r)/H(f))^{0.54}$

Q(r) = COMPUTED DISCHARGE AT THE SPECIFIED RESIDUAL PRESSURE IN igpm.

Q(f) = TOTAL DISCHARGE DURING TEST IN igpm.

H(r) = DROP IN PRESSURE FROM ORIGINAL VALUE (STATIC PRESSURE AT GAUGE HYDRANT) TO SPECIFIED RESIDUAL IN psi.

H(f) = PRESSURE DROP DURING TEST IN psi.

**Flow Test # 1**

**Flow Test # 2**

**CALCULATED FLOW AT FLOW HYDRANT** 0 = 0 igpm      0 igpm

**THEORETICAL FLOW AT HYDRANT AT A DESIRED RESIDUAL PRESSURE:** 0 20 psi = ▼ #DIV/0! igpm.      ▼ #DIV/0! igpm.

Based on this hydrant flow test, and background demand at time of the test, the theoretical flow at Hydrant 0 is \_\_\_\_\_ igpm at a residual pressure of 20 psi.



## FLUSHING/TESTING/ DISINFECTION REPORT

**PROJECT:** \_\_\_\_\_

**DATE:** \_\_\_\_\_

**LOCATION:** \_\_\_\_\_

**FILE #:** \_\_\_\_\_

**DESCRIPTION:** \_\_\_\_\_

**FLUSHING:**

Water source: \_\_\_\_\_ Minimum flushing volume (Pipe volume x 3): \_\_\_\_\_

Estimated flow rate: \_\_\_\_\_ Estimated flow time required: \_\_\_\_\_ Flushing completed: \_\_\_\_\_

**PRESSURE TEST:**

Allowable leakage =  $NDP^{1/2}/(65000)(2Hr)$

N = Number of pipe joints = \_\_\_\_\_ D = Nominal diameter of pipe (mm) = \_\_\_\_\_

Static Pressure: \_\_\_\_\_ P = Average test pressure during leakage test = \_\_\_\_\_  
(Minimum 1,380 kPa (200 psi))

Allowable leakage calculated: \_\_\_\_\_ Start time: \_\_\_\_\_ End time: \_\_\_\_\_

Test leakage recorded: \_\_\_\_\_ Pass: \_\_\_\_\_ Fail: \_\_\_\_\_

**DISINFECTION:**

Chlorine source: \_\_\_\_\_ Calculated dosage: \_\_\_\_\_ Background residual: \_\_\_\_\_

Start time \_\_\_\_\_ Starting residual: \_\_\_\_\_ End time : \_\_\_\_\_ End residual: \_\_\_\_\_

Chlorine flushed: \_\_\_\_\_ 24 Hour stand time Start: \_\_\_\_\_ End: \_\_\_\_\_

**BIOLOGICAL TEST:**

Sample: Date: \_\_\_\_\_ Time: \_\_\_\_\_ Testing Lab: \_\_\_\_\_

Number of samples required: \_\_\_\_\_ Sample(s) collected by: \_\_\_\_\_

Test results: Pass: \_\_\_\_\_ Fail: \_\_\_\_\_ (Copy of lab results attached)

Testing/flushing points removed: \_\_\_\_\_



## FLUSHING/TESTING/ DISINFECTION REPORT

---

### CONSULTING ENGINEERS CERTIFICATION:

I hereby certify that all flushing, disinfection and testing has been completed in accordance with the requirements of Subdivision and Development Servicing Bylaw No. 4293.

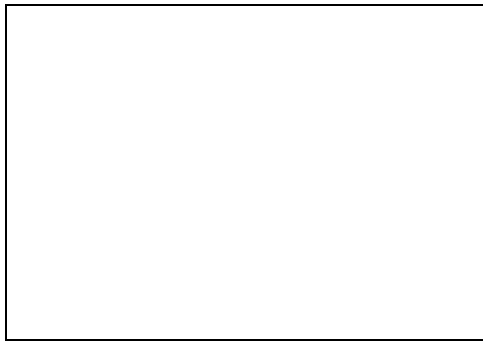

Engineer's Seal

\_\_\_\_\_  
\_\_\_\_\_

Signature and name of the Consulting  
Engineer responsible for Design

---

### CITY CONNECTION APPROVAL:

\_\_\_\_\_

Date

\_\_\_\_\_

City Engineer

**Subdivision and Development Servicing Bylaw No. 4293**

**Schedule “D”**



**CITY OF SALMON ARM**

**APPROVED MATERIAL LIST**

Contact the City of Salmon Arm for a copy of the latest Approved Material List:

Gabriel Bau Baiges, P.Eng.  
City Engineer  
[gbaubaiges@salmonarm.ca](mailto:gbaubaiges@salmonarm.ca)  
(250) 803-4024