

INFORMATIONAL CORRESPONDENCE -

- | | | |
|-----|--|---|
| 1. | K. Campbell – email dated August 9, 2021 – Peter Jannik Park | A |
| 2. | B. Harper – email dated August 13, 2021 – 10% Penalty (Homeowner Grant) | A |
| 3. | J. Jones, Office Manager and J. de Boer, General Manager, Salmar Cinemas – email dated August 12, 2021 – Salmar Community Association | N |
| 4. | S. Caner, Shuswap Food Action Society – letter dated August 18, 2021 – Downtown Farmer’s Market | A |
| 5. | B. M’Clellan, Shuswap Dragon Boat Society – letter dated August 19, 2021 – Dragon Boar Storage Shed (“Shed”) modifications to original design | A |
| 6. | J. Jensen, Director, Building Policy, Ministry of Attorney General and Minister Responsible for Housing – email dated August 10, 2021 – BC Building Code Accessibility Update (LG Officials) | N |
| 7. | B. Frenkel, UBCM President – letter dated August 11, 2021 – Canada Community-Building Fund/Gas Tax Fund: Community Works Fund Top-up Payment and Updated Eligibility Guidelines | N |
| 8. | P. Rasmussen, Assistant Deputy Minister, Ministry of Forests, Lands, Natural Resource Operations and Rural Development – letter dated August 12, 2021 – Salmon Arm Water Licence Application | N |
| 9. | L. Beare, Minister, Ministry of Citizens’ Services – letter dated August 18, 2021 – High-speed Internet | N |
| 10. | Fortis BC – email dated August 16, 2021 – Nominate a charity worthy of receiving \$15,000 from FortisBC | N |

N = No Action Required
 A = Action Requested

S = Staff has Responded
 R = Response Required

-----Original Message-----

From: keith campbell

Sent: Monday, August 9, 2021 1:58 PM

To: Caylee Simmons

Subject: Peter Jannik Park

Hello Caylee

Not sure if I spelled that right.

This is Keith Campbell

#22-601 Beatty ave NW

604-910-4609

As a resident of Salmon Arm I am asking to have signs posted at Peter Jannik Park to have dogs on Leash.

Reasons are—

-Wild life have been attacked.

-Other dogs on leash have been attacked.

People walking though the park have been attacked.

-Dog owners don't pick up after they dogs.

-When asked the off leash dog owners to have some control of there dogs normally that goes into a yelling match.

-By-laws officer have a hard time enforcing these off leash dogs because there is no sign to do so.

-Dog owners have ripped branches off tree so they can have sticks to play with they off leash dogs.

-I don't walk my dog on leash at Peter Jannik park anymore because of me and my dog being attacked by dog owners who are not a responsible dog owners.

Residents who live close to Peter Jannik Park are not happy with off leash dogs barking.

-It's bad enough dealing with homeless people not picking up they garbage.

-Thank you for taking your time to hear about the on going problems a lot of people are having at the park.

Sent from my iPhone

From: Brian Harper [REDACTED]
Sent: Friday, August 13, 2021 6:13 PM
To: Finance <Finance@salmonarm.ca>
Subject: Re: 10% Penalty (Homeowner Grant) Folio [REDACTED]

Please note a correction to our email earlier today (August 13, 2021). The date we received an email from Biannco was August 9, 2021 not August 2, 2021.

Thank you.
Alana and Brian Harper

On Fri., Aug. 13, 2021, 2:52 p.m. Brian Harper, [REDACTED] wrote:
Hello,

Further to our conversation, and as requested, I am writing to dispute the 10% penalty which has been applied to our account.

My wife and I attended city hall prior to July 1, 2021 and paid our property taxes. The female employee serving us did not advise us that we were responsible for applying for the BC Home Owner Grant (HOG) either online or by phone. We left city hall on the understanding that our Salmon Arm property taxes were fully paid and dealt with, just as we have for the past 31 years.

On August 2, 2021, we received an email from Bianca Colonna advising us that our Prepayment Plan Account had an outstanding balance of \$1149.50, and that a 10% penalty (\$104.50) was applied to our account on July 3, 2021 as we were late in applying for our Homeowner Grant.

We called Bianca and she explained to us that effective 2021, homeowners are now responsible for applying for the HOG online or by phone. We explained to her that we had no knowledge of this requirement, and if we had known of this requirement, we would have done so prior to the deadline. Frontline staff at city hall need to ensure that the public they assist are fully aware of details about any changes to government programs and policies city hall administers. I worked for the BC Government for 35 years and was responsible for gov't program delivery and I and my colleagues went the extra mile to facilitate public knowledge of same when changes were made. City Hall staff need to do the same.

We are appealing the penalty of \$104.50. and request that it be waived.

Thank you.
Brian and Alana Harper
[REDACTED]
Salmon Arm, BC

From: office@salmartheatre.com
Sent: Thursday, August 12, 2021 2:12 PM
To: Chelsea Van de Cappelle
Subject: Salmar Community Association

Hi Chelsea,

I wanted to send you an email on behalf of the Management of the Salmar Community Association to thank you, and the City of Salmon Arm for this grant. This has been a tough run for the Salmar since March of 2020, and this money will be huge in aiding us back on our feet to once again serve our community in all aspects that we have been able to previous to Covid. We are very grateful that we were informed about this through our Mayor, Alan Harrison and able to access this very generous grant for our Association. We appreciate the ease and how straight forward the application process was.

Sincerely,

Jody Jones (Office Manager) and Joel de Boer (General Manager)



Jody Jones
Office Manager

Phone: 250-832-2263

Email: office@salmartheatre.com

100 Hudson Ave NW
Salmon Arm, BC
V1E 4N5

www.salmartheatre.com



August 18th, 2021

Shuswap Food Action Society would like to begin by thanking the City of Salmon Arm and Council for their ongoing support of the Downtown Farmer's Market. Despite COVID protocols limiting vendor numbers and ongoing smoke, our market attendance continues to be good and our farmers and artisans feel well supported by the community. Since loosening of restrictions, we have welcomed new vendors and hosted music on the Ross Street stage. We continue to have consistent attendance of 1,000-1,500 residents and visitors pass through the market each week. We also operate a number of local food box programs and run the BCFMA Nutrition Coupon program to provide "market dollars" to low-income populations to purchase fruit, vegetables, eggs or meat.

Given for our community's support of local food, and our farmer's growing capacity to provide food throughout the year and desire to continue selling it, we are requesting to extend the season of the Downtown Farmer's market. Once our regular market season is completed (Thanksgiving weekend), we would like to continue with a bi-weekly "winter" Saturday market. There would likely be 10-15 vendors involved in this market, mostly for food, and we would run the market later in the day (12-3 pm or 1-4 pm), to accommodate any snow clearing and encourage warmer temperatures for vendors and consumers alike. Our aim would be to have the market continue until the following market season begins, or until farmer's and vendors run out of food. We believe our market encourages residents to visit the Downtown core, shop at other downtown businesses and contribute to a feeling of community.

Thank you for your consideration,

Serena Caner



August 19, 2021

To: City of Salmon Arm ("City")

Re: Dragon Boat Storage Shed ("Shed") modifications to original design

Please find enclosed the following documents submitted for review and approval of the proposed Shed:

- A drawing of the Shed (separate pdf document);
- Updated list of primary contacts (below);
- Updated list of contacts for Dragon Boat participants (below); and
- Description of changes to shed design and construction (below).

The primary contacts and their role for this project are:

- Brenda M'Clellan, Shuswap Dragon Boat Society – Friends Abreast, Project Organizer; and
- Don Hinbo, HINDBO Construction Group Inc. (construction)

The Dragon Boat clubs and their primary representatives are:

- Sandra Konicek, Shuswap Grey Grebes Paddling Society;
- Janet Ferns, Shuswap Dragon Boat Society – Friends Abreast; and
- Blair Acton, Shuswap Rowing and Paddling Club (Pink Piston Paddlers and Dragon Tao).

1. Changes to Shed Design, please refer to new drawing for changes:

a. Dimensions:

- Original Proposal** was approximately 12.5' by 4' by approximately 9' (width, depth and height) with 3 entry doors, one for each team. Interior dimensions are to be approximately 4' by 4' by 6'. Exact dimensions are on Diagram 2. Total approximate weight is 1500 KG or 3307 LB.
- Changed to** 10' by 4' by approximately 8' with a sloping roof (width, depth and height) with one common entry door. Approximate weight was not provided but can be supplied on request.

b. Construction:

Original Proposal:

- Pre-build Shed components at contractors site;
- Disassemble and transport components to Wharf;
- At Wharf, attach Shed base to Wharf and reassemble shed components; and
- Attach roof joice and finish roofing at Wharf.

Changes to Proposal:

- No change; and
- Transport Shed to Wharf and assemble as required.

c. Materials:

Original Proposal:

- 2" by 4" framing;
- Board and Batten siding will be Cedar;

- iii. Roofing will be ¾" plywood with red metal cladding;
- iv. Two interior dividing walls will be 2" by 4" with ½" plywood on either side; and
- v. Doors are to be made using Board and Batten siding and 2" by 4" supports.

Changes to Proposal:

- i. No Change;
 - ii. Siding will be corrugated metal siding (charcoal);
 - iii. Roofing will be corrugated metal (red) with ½" plywood and 2" by 4" rafters;
 - iv. No interior walls; and
 - v. One commercial flat panel metal door with security plate.
- d. Timing change:**
- i. To accommodate both the City and Hinbo Construction Group Inc. construction is anticipated to be between now and fall 2021 with installation to follow shortly thereafter and no later than April 2022.
- e. Security change:**
- i. As a metal door is being installed with a security plate, no additional bars are considered necessary.
 - ii. A solid floor (3/3" pressure treated Plywood) is being installed to ensure nothing can get in from the bottom and nothing can drop through the Wharf boards.

2. Other upgrades to be installed by the teams:

The Interior of the Shed may be customized to add:

- a. Lockers or bins; and if space permits could include:
- b. Life jacket hooks; and
- c. Minor hooks or holders for buckets and cleaning supplies.

These upgrades will be done after the Shed is in place and secured.

3. Budget of Sponsorship funding:

- a. Hinbo Construction Group Inc. has kindly volunteered to build the Shed as a community project.
- b. To offset some of the construction costs and to assist with appropriate construction recognition signage and possible interior enhancements, the Shuswap Dragon Boat Society – Friends Abreast applied for and received a Grant in Aid Community Grant.
- c. Therefore, a budget for construction has not been requested at this time. A summary of the costs will be obtained after construction for purposes of insuring the structure.

On behalf of the Dragon Boat teams, I would like to thank the Mayor and Council for approving our original proposal for the common shed and for the assistance provided by City Staff. We are very excited to finally bring this project to the point of construction. If you have any additional questions, please contact either the undersigned or the Don Hinbo and one of us will respond as quickly as possible.

Sincerely,

Brenda M'Clellan

Shuswap Dragon Boat Society – Friends Abreast, Project Organizer on behalf of the Dragon Boat teams

Attachments: 2021 Dragon Boat Shed V1.0

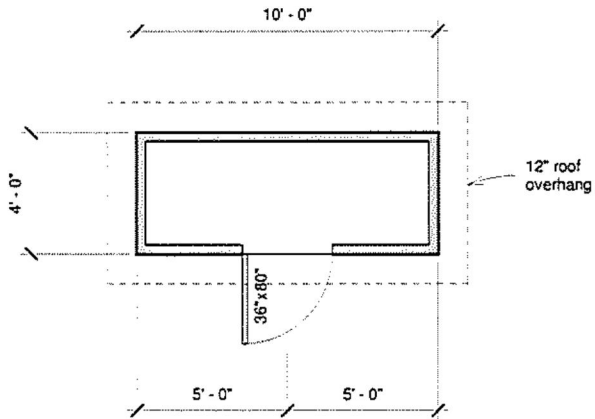

1 Plan
1/4" = 1'-0"

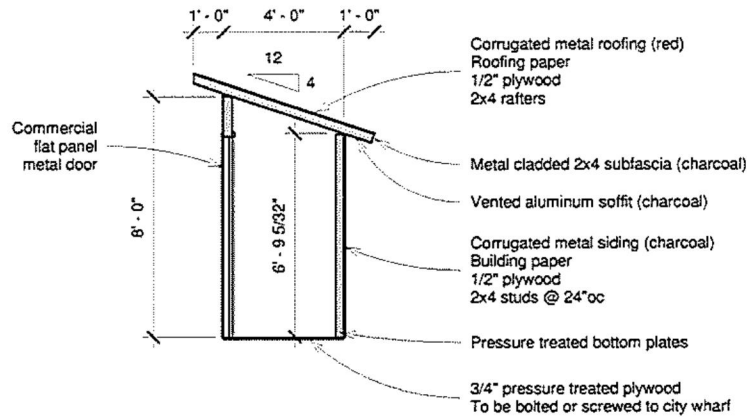

2 Section
1/4" = 1'-0"

Proposed Shed
for the
Dragon Boat Society

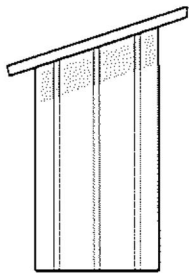

6 Left Elevation
1/4" = 1'-0"

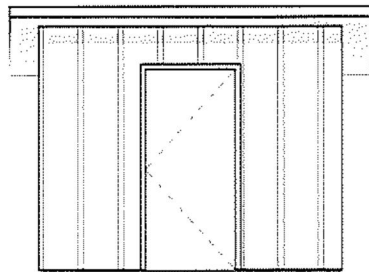

3 Front Elevation
1/4" = 1'-0"

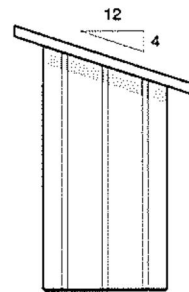

4 Right Elevation
1/4" = 1'-0"

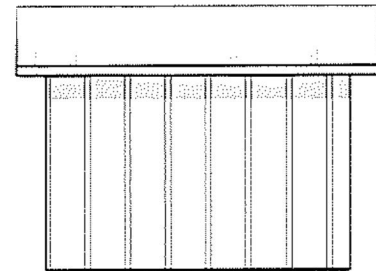

5 Rear Elevation
1/4" = 1'-0"

From: OHCS Building & Safety Standards Branch OHCS:EX
Sent: Tuesday, August 10, 2021 2:58 PM
To: OHCS Building & Safety Standards Branch OHCS:EX
Subject: BC Building Code Accessibility Update (LG Officials)

Dear Local Government Officials:

The Attorney General and Minister Responsible for Housing is working with the Parliamentary Secretary for Accessibility to fulfill the mandate commitment to include changes in the next British Columbia Building Code to make new buildings more accessible for all people.

Building Code Public Engagement

In fall 2021, the Building and Safety Standards Branch will seek public feedback regarding the British Columbia Building Code's accessibility requirements for new buildings.

Your input is important. Please stay tuned for a fall engagement invitation about how and when you can participate. Details will also be provided on the building code public review [website](https://www2.gov.bc.ca/gov/content/industry/construction-industry/building-codes-standards/bc-codes/public-review) [LINK <https://www2.gov.bc.ca/gov/content/industry/construction-industry/building-codes-standards/bc-codes/public-review>] in the fall.

Building Code Accessibility

The Building Code's accessibility requirements govern the design and construction of buildings so that people can approach, enter, and exit buildings, and move safely throughout to enjoy the facilities and services.

The 2018 British Columbia Building Code accessibility requirements are based on the 2015 National Building Code with some improvements to achieve higher levels of accessibility.

British Columbia is committed to harmonizing the British Columbia Building Code with the National Building Code requirements to reduce differences and provide consistent Canadian codes and standards.

The Building and Safety Standards Branch is working closely with national partners to develop new accessibility requirements for adoption in future national and provincial building codes.

More information about building accessibility requirements is available on our [website](https://www2.gov.bc.ca/gov/content/industry/construction-industry/building-codes-standards/accessibility) [LINK <https://www2.gov.bc.ca/gov/content/industry/construction-industry/building-codes-standards/accessibility>].

Removing barriers to accessibility and inclusion experienced by British Columbians will help create better buildings and stronger communities for all people.

Please share this information with others in your organization as appropriate.

Sincerely,

Jun'ichi Jensen
Director, Building Policy
Building and Safety Standards Branch
Office of Housing and Construction Standards
Ministry of Attorney General and Minister Responsible for Housing

Recognizing with gratitude the Lekwungen peoples and the Songhees and Esquimalt Nations upon whose traditional territories we live and work.

August 11, 2021

Mayor Alan Harrison
City of Salmon Arm
Box 40
Salmon Arm, BC V1E 4N2

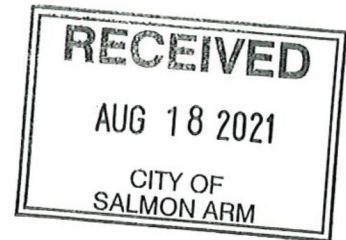

Dear Alan Harrison:

**RE: CANADA COMMUNITY-BUILDING FUND/GAS TAX FUND:
COMMUNITY WORKS FUND TOP-UP PAYMENT AND UPDATED ELIGIBILITY
GUIDELINES**

I am pleased to advise that UBCM is in the process of distributing a top-up to your Community Works Fund (CWF) payment for fiscal 2021/2022. An electronic transfer of \$800,759.91 is expected to occur the week of August 16, 2021.

This additional one-time payment from UBCM for the CWF was approved for disbursement by the Government of Canada to supplement the fiscal 2021/2022 allocation which was delivered in July.

Also announced by the Government of Canada is the expansion of CWF investment categories to now include fire halls and fire station infrastructure.

CWF is made available to eligible local governments by the Government of Canada pursuant to the Administrative Agreement on the Federal Gas Tax Fund in British Columbia. Funding under the program may be directed to local priorities that fall within one of the eligible project categories.

Further details regarding use of CWF and project eligibility are outlined in your CWF Agreement and details on the Canada Community-Building Fund (Gas Tax Fund) can be found on our website at www.ubcm.ca.

For further information, please contact Canada Community-Building Fund Program Services by e-mail at ccbf@ubcm.ca or by phone at 250-356-5134.

Yours truly,

A handwritten signature in black ink, appearing to read "B. Frenkel".

Brian Frenkel
UBCM President

PC: Chelsea Van de Cappelle, Chief Financial Officer



Reference: 265928

August 12, 2021

His Worship Alan Harrison, Mayor
City of Salmon Arm
Box 40
500 - 2 Avenue NE
Salmon Arm, British Columbia
V1E 4N2

Dear Mayor Harrison:

Thank you for your letter, dated June 7, 2021, to Minister Katrine Conroy expressing your concerns regarding a water licence application in the Salmon Arm area. I have been asked to respond on her behalf.

The proponent has applied for a water license, pursuant to the *Water Sustainability Act* (the Act), for 131,490 cubic metres per year for the purposes of establishing a commercial water bottling operation.

A proponent wanting to divert and/or use water in BC is required to make application for a licence, pursuant to the Act and associated regulations.

Statutory decision makers are required to adjudicate license applications and make determinations in accordance with Section 9 of the Act.

In the water license application adjudication process, potentially affected parties are given notice of the application and can provide comments for the ministry decision maker to consider. Consistent with the Act, those parties are designated as:

1. Other water license holders reasonably likely to be affected;
2. Riparian landowners reasonably likely to be affected; and
3. Anyone whose land is reasonably likely to be affected if the application is granted.

Generally, such parties tend to be located in close proximity to the application, e.g. neighbours, nearby well owners, etc. In the future, the Okanagan Shuswap Natural Resource District Water Authorizations team can notify the city of Salmon Arm for large groundwater license applications if the city so wishes.

His Worship Alan Harrison, Mayor

For this particular application, notices have been sent to potentially affected parties and responses have been gathered. The decision rests with the Statutory Decision maker.

There is no moratorium on issuing ground water licenses in the area. However, an application may be rejected if it is determined that the operation of the well would unduly impact affected parties or the environment.

The parties have the right to appeal the final decision to the BC Environmental Appeal Board.

If you wish to discuss your concerns further, or would like more information, please contact Tony Zanotto at: tony.zanotto@gov.bc.ca

Thank you for expressing your concerns regarding this application.

Sincerely,



Paul Rasmussen
Assistant Deputy Minister
South Area

pc: Honourable John Horgan, Premier of British Columbia
Honourable Katrine Conroy, Minister of Forests, Lands, Natural
Resource Operations and Rural Development
Honourable George Heyman, Minister of Environment and Climate Change Strategy
Tony Zanotto, Acting Resource Manager, South Area



BRITISH
COLUMBIA

August 18, 2021

Ref: 115524

First Nations Leaders, Mayors, Regional District Chairs and Alternates
Attendees at the June 24, 2021, Passive Infrastructure Table

Dear Attendees:

Thank you for taking the time to join me and my colleagues Bruce Ralston, Minister of Energy, Mines and Low Carbon Innovation, and Roly Russell, Parliamentary Secretary for Rural Development, on June 24, 2021 to discuss passive infrastructure and its role in helping to expand connectivity to more homes throughout B.C. For those that were not able to attend the meeting, you are receiving this letter as we would like to share with you a summary of the insightful discussions that took place.

We appreciated hearing about the experiences and concerns with accessing the various types of passive infrastructure, and perspectives on how we can work together to overcome some of the challenges. Key themes emerged from the conversation that highlight the need to reduce barriers to connectivity, including addressing common and systemic service delivery, and policy gaps that include permitting, access to utility poles, and taxation. Some of these issues will be easier to tackle than others, and work is underway to do so. These issues will require a collaborative approach with all levels of government and industry to solve them step by step.

We know that high-speed internet is as crucial today as electricity and roads, and we heard during the roundtable that connectivity should be deemed an essential service - a fourth infrastructure by default - and as such be considered in all land-based infrastructure planning and decision-making. This includes better utilization of existing infrastructure such as rail lines for public benefit.

Challenges around timely access to utility poles formed a key part of our discussion. We heard that to enable internet service providers to invest and deploy high-speed networks, access to poles must be more equitable, affordable, timely, transparent, and predictable. Communities, and small and large internet service providers, face considerable challenges as they navigate the permitting process to allow access to utility poles. Excessive wait times to gain access to poles was highlighted as a key reason for project delays.

.../2

Ministry of
Citizens' Services

Office of the Minister

Mailing Address:
PO Box 9068 Stn Prov Govt
Victoria BC V8W 9E2
Phone: 250 387-9699
Fax: 250 387-9722

Location:
Room 151
Parliament Buildings
Victoria BC V8V 1X4
www.gov.bc.ca/citz

Item 12.1.9

To address this issue, my ministry established a permitting and single window process for projects funded through the Connecting British Columbia StrongerBC funding intake. We will continue to use this mechanism to support projects, communities, and service providers by addressing permitting issues that have the potential to delay projects. Additionally, we have initiated work with the Ministry of Mines and Low Carbon Innovation, BC Hydro and TELUS to target improved access to hydro poles.

It was interesting to hear more about your concerns regarding 'future-proofing' connectivity. Focusing on achieving 50/10 Mbps, while important, is not sufficient, and planning for emerging technologies, combined with a desire for a lifestyle afforded by working remotely in rural communities, will continue to accelerate demand for connectivity into the future.

I want to assure you that we listen to your concerns and there are some actions we have taken recently in response to feedback. In cooperation with UBCM, we support the Regional Connectivity Knowledge Network (RCKN) and the opportunity it provides us to be in open, ongoing dialogue directly with communities to clearly understand where policy and program improvements can be made. We also recognize the work of the Federation of Canadian Municipalities with its supports for communities to do blanket permitting to accelerate connectivity projects.

Calls to address internet service speeds used to determine program funding eligibility were also raised, and I am pleased to report that we took steps to address the funding eligibility issue in early May when the Ministry of Citizens' Services, UBCM, and Northern Development Initiative Trust (NDIT) launched an independent study to understand why there are differences between the broadband internet speeds experienced in some B.C. communities, and the 50/10 Mbps speed identified on the federal government's National Broadband Internet Service Availability Map.

The study, which is underway, will produce information on internet speeds experienced in rural and remote communities, supporting analysis, and informing dialogue between the NDIT, Indigenous and local governments, internet service providers, the Province, and the federal government. Data gathering and analysis continues this summer, and we anticipate the study results in the fall. We encourage everyone to participate in the study by having their residents, businesses, and other community stakeholders complete the CIRA Internet speed test so that we can improve the accuracy and depth of the Internet speed data for their area. The link to the speed test can be found at <https://performance.cira.ca/bc>.

While we have made some progress and appreciate your acknowledgement that efforts by the Province have benefitted many areas, we also understand that bringing B.C. to a place where everyone can access high-speed internet requires solutions for the remaining connectivity needs, which are higher cost and require different strategies to resolve. In 2017, we estimated 25% of rural and Indigenous communities were fully connected with all households having access to minimum speeds of 50/10 Mbps. Today, that percentage is nearing 40%. When all the projects in flight by service providers are complete, including those that are federally and/or provincially funded, we will see that number increase to over 60%. This is progress but going forward we will need to tackle some of the most challenging and expensive areas to connect, and novel approaches will be required to fill in the remaining gaps.

Working to connect all people in B.C. – regardless of where they live – is a priority for our government. Building on the Province’s most recent investments totalling \$180 million, Budget 2021 establishes stable base funding of \$40 million over the plan to further invest in the Province’s connectivity strategy. This will provide better high-speed internet and cell coverage to help connect more people in rural, remote and Indigenous communities and Connecting British Columbia funding is available now for projects.

My ministry staff would welcome continuing the dialogue with you and your community leaders to better understand the issues. If you would like to discuss this further or receive additional information on the Province’s activities to expand high-speed internet connectivity and on passive infrastructure, please contact [Howard Randell](#), Executive Director, Network BC at 250-415-6867. For information about the RCKN group or other community planning questions, please contact [Jeanne Holliss](#), A/Executive Director, Connected Communities at 250-516-3848.

We all have a vested interest in improving services in B.C., and solutions begin with a common understanding of the nature of the barriers, and how we can each effect change. We continue to benefit from the insights each of you shared. Thank you again for your participation, ongoing leadership, and collaboration as we collectively work towards a better future for British Columbians.

Sincerely,



Lisa Beare
Minister

pc: Honourable Bruce Ralston
Minister of Energy, Mines and Low Carbon Innovation

Roly Russell
Parliamentary Secretary for Rural Development
Ministry of Forests, Lands, Natural Resource Operations and Rural Development

Connected Communities
ConnectedCommunitiesBC@gov.bc.ca

Erin Jackson

From: FortisBC <no-reply@email.myfortisbc.com>
Sent: Monday, August 16, 2021 1:02 PM
To: Erin Jackson
Subject: Nominate a charity worthy of receiving \$15,000 from FortisBC

2021-Aug-10

A long-exposure photograph of a night sky over a lake, showing star trails in a circular pattern. The lake reflects the lights from a town on the right and the dark silhouettes of mountains on the left.

Nominate a charity in your community

**Please join us again this year in celebrating the charities
working to strengthen our communities.**

Giving back to the communities where we live and work is an important part of helping to create a sustainable future for British Columbians. As we reach out once again to members of the Union of BC Municipalities, we invite each of you to **nominate a local charity** deserving of a \$15,000 donation to support a project in your community.

The deadline for submissions is September 17, 2021. Three awards of \$15,000 will be given. Winners will be announced on Tuesday, November 9, 2021. [Terms and conditions apply.](#)

[Nominate now](#)